

RESOLUTION NO. R-2019-113

A RESOLUTION OF THE CITY COUNCIL OF THE CITY OF BASTROP, TEXAS, AWARDING A CONTRACT FOR THE CITY OF BASTROP STREETS, PAVEMENT AND PREVENTATIVE MAINTENANCE PROJECT TO ANGEL BROTHERS ENTERPRISES, LTD. IN THE AMOUNT OF ONE MILLION ONE HUNDRED EIGHTY-NINE THOUSAND ONE HUNDRED THIRTY-NINE DOLLARS AND EIGHTY CENTS (\$1,189,139.80) AS ATTACHED IN EXHIBIT A; AUTHORIZING THE CITY MANAGER TO EXECUTE ALL NECESSARY DOCUMENTS; PROVIDING FOR A REPEALING CLAUSE; AND ESTABLISHING AN EFFECTIVE DATE.

WHEREAS, the City of Bastrop City Council understands the importance of public safety provided by performing construction management infrastructure improvements; and

WHEREAS, the City of Bastrop City Council understands providing maintenance on current City Infrastructure should be cost effective; and

WHEREAS, the City of Bastrop understands the importance of focusing on infrastructure improvements in the area of street maintenance; and

WHEREAS, the City of Bastrop has chosen Walker Partners from a list of qualified consulting firms identified by the City of Bastrop City Council on July 10, 2018; and

WHEREAS, Walker Partners has conducted a Request for Proposals for the City of Bastrop Streets, Pavement and Preventative Maintenance project; and

WHEREAS, On October 24, 2019, three proposals were received for the City of Bastrop Streets, Pavement and Preventative Maintenance Project. Walker Partners reviewed and ranked the proposals and recommends that Council allow the City Manager and Staff to enter into negotiations with the highest-ranking offeror for the project as the best value for the City of Bastrop.

NOW, THEREFORE, BE IT RESOLVED BY THE CITY COUNCIL OF THE CITY OF BASTROP, TEXAS:

Section 1. The City Council of the City of Bastrop, Texas has found Walker Partners to be a subject matter expert in the fields of water/wastewater, streets/drainage, and land survey and accepts Walker Partner's recommendation that Council allow the City Manager and Staff to enter into negotiations with the highest ranking offeror for the City of Bastrop Streets, Pavement and Preventative Maintenance Project.

Section 2. The City Manager is hereby authorized to draft and execute a contract with the highest-ranking offeror in an amount not to exceed \$1,189,139.80 as attached in Exhibit A, as well as all other necessary documents.

Section 3. This resolution shall take effect immediately from and after its passage, and it is duly resolved.

DULY RESOLVED AND ADOPTED by the City Council of the City of Bastrop this 26th day of November, 2019.

APPROVED:



Connie B. Schroeder, Mayor

ATTEST:



Ann Franklin, City Secretary

APPROVED AS TO FORM:

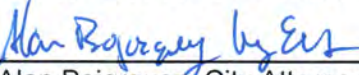

Alan Bojorquez, City Attorney

CITY OF BASTROP
STREETS, PAVEMENT, AND PREVENTATIVE
MAINTENANCE

PROJECT MANUAL

SEPTEMBER 2019

RFP No. 20-001

PROJECT NUMBER 4-01126



R. Alan Munger, PE

9/25/2019

PROJECT MANUAL
as part of
the
Bidding Documents

PROJECT MANUAL
as part of
the
Contract Documents
(including Addenda numbers
— to —, inclusive)



T.B.P.E. Registration No. 8053

DOCUMENT 00 01 10
TABLE OF CONTENTS

<u>Section</u>	<u>Title</u>	<u>No. of Pages</u>
DIVISION 00 - PROCUREMENT AND CONTRACTING REQUIREMENTS		
00 01 10	Table of Contents.....	2
PROCUREMENT REQUIREMENTS		
00 11 12	Invitation to Submit Proposals.....	1
00 21 13	Instructions to Offerers	9
00 21 14	Statement of Qualifications.....	5
00 41 00	Proposal Form.....	4
00 43 13	Offerer's Bond	2
CONTRACTING REQUIREMENTS		
00 45 00	Notice of Award.....	1
00 46 00	Notice to Proceed.....	1
00 52 00	Agreement Form	5
00 61 13	Performance Bond	2
00 61 14	Payment Bond.....	2
00 72 15	General Conditions	39
00 73 13	Supplementary Conditions.....	5
00 83 00	Wage Rates & Payroll Reporting.....	4
00 91 13	Addenda	1
	Non-Collusion Affidavit.....	1
	Sample Forms	
	Work Change Directive	1
	Field Order.....	1
	Change Order.....	2
	Contractor's Application for Payment.....	4
	Certificate of Substantial Completion.....	1

<u>Technical Specifications</u>	<u>No. of Pages</u>
---------------------------------	---------------------

WALKER PARTNERS – TECHNICAL SPECIFICATIONS

DIVISION 01 – GENERAL REQUIREMENTS

01 10 00	Summary	3
01 20 00	Price and Payment Procedures.....	4
01 21 00	Mobilization, Traffic Handling, and Incidentals.....	1
01 30 00	Administrative Requirements	4
01 33 00	Submittal Procedures	6
01 40 00	Quality Requirements	4
01 50 00	Temporary Facilities and Controls.....	6
01 60 00	Product Requirements.....	2
01 70 00	Execution and Closeout Requirements	5

DIVISION 33 – UTILITIES

33 01 31 Manhole Grade Adjustment..... 4

CITY OF AUSTIN – STANDARD SPECIFICATIONS

Item 802S – Project Signs

TEXAS DEPARTMENT OF TRANSPORTATION (TxDOT) STANDARD SPECIFICATIONS

The Texas Department of Transportation “Standard Specifications for Construction and Maintenance of Highways, Streets, and Bridges,” 2014 Edition, is incorporated herein by reference for all intents and purposes. If a standard specified in that document conflicts with a standard included within a bid specifications document, the standard in the bid specifications document controls. If the standard is still unclear, the Engineer will determine which standard controls and his determination shall be final.

TxDOT Special Specifications

- 3005 – Scrub Seal Treatment
- 3028 – Frictional Asphaltic Surface Preservation Treatment

Attachments

1. Special Provisions
2. General Notes
3. Streets Maintenance Overview
 - Map A
 - Map A1
 - Map A2
 - Map A3
4. Streets Maintenance – Crack Seal and Flexible Pavement Repair
5. Program Preventative Maintenance Maps
 - Map B
 - Map B1
 - Map B2
 - Map B3
6. Preventative Maintenance Basis of Estimate
7. Details Sheets
 - C001
 - C002
 - C003
 - C004
 - C005
 - C006

END OF TABLE OF CONTENTS

10

SECTION 00 11 12

INVITATION TO SUBMIT PROPOSALS

City of Bastrop (Owner) is requesting Competitive Sealed Proposals for the Streets, Pavement, and Preventative Maintenance project, from qualified contractors, to be received until 2:00 PM, on October 24, 2019, in its offices located at 1311 Chestnut Street, Bastrop, TX, 78602. Sealed competitive proposals will be publicly opened and read aloud at shortly thereafter at same location. Proposals are invited for furnishing all labor, equipment, and materials necessary for construction of the following:

RFP No. 20-001 – City of Bastrop - Streets, Pavement, and Preventative Maintenance

Streets, Pavement, and Preventative Maintenance consists of crack seal, flexible pavement repair, fog seal, scrub seal, seal coat, and add alternate thin overlay mix. Project will be awarded on a number of factors including cost, experience of contractor, schedule, and prior work experience.

Proposals must be submitted on forms provided in Proposal Documents and accompanied by a Proposal Security in the penal sum of not less than five percent (5%) of base proposal amount, payable without recourse to Owner. Proposal Security may be in either form of a cashier's check or Offeror's Bond from a security company approved to conduct business in State of Texas as a guarantee that offeror will enter into a contract and execute a 100% payment bond within fifteen (15) days after issuance of a notice of award to that Offeror. Proposals not accompanied by such Security or received after designated proposal time will not be considered. Refer to other proposal requirements described in Document 00 21 13 – Instructions to Offerors.

Copies of Proposal Documents (Project Manual and Drawings) may be obtained electronically online from CivCast (www.civcastusa.com). For more information, contact Rachel Murphy at rmurphy@walkerpartners.com or (254) 714-1402.

Owner reserves the right to reject any or all Proposals and to waive informalities and irregularities.

END OF SECTION



SECTION 00 21 13

INSTRUCTIONS TO OFFERORS

COMPETITIVE SEALED PROPOSALS

1. Overview of Request for Proposal Process.
 - 1.1 Objective of Request for Proposal (RFP) process is to competitively procure services with a qualified contractor whose Proposal provides best value for the City of Bastrop Streets, Pavement, and Preventative Maintenance project. Proposals will be received, publicly opened, and names and monetary Proposals of each Offeror read aloud. Subsequently, Proposals will be ranked according to criteria described in this RFP Document. Both cost and non-cost factors will be evaluated and scored. One or more Offerors may be invited back for discussions or to present their Proposal to Owner before final rankings are made. Owner may enter into contract negotiations with highest ranked firm for completion of Work. If negotiations with highest ranked firm are unsuccessful, Owner will formally close negotiations with this firm and initiate contract negotiations with next highest ranked firm. Upon agreement between both parties, a Contractor-executed Contract may be recommended for approval by Owner's governing body. Upon approval, Contract will be executed by Owner.
2. Defined Terms.
 - 2.1. Definitions for the following terms used in these Instructions do not replace definitions for similar terms that may be contained within other sections of Contract Documents.
 - 2.2. Certain additional terms used in these Instructions to Offerors have meanings indicated below and are applicable to both singular and plural thereof.
 - 2.2.1. Addendum or Addenda- Additions, deletions, and/or changes to any part of RFP issued in writing by Owner prior to Proposal due date and time.
 - 2.2.2. Apparent Best Value Offeror-Offering Firm whose Proposal for completion of Work provides best value for Owner as defined by ranking criteria detailed in Article 11 of Instructions to Offerors.
 - 2.2.3. City Council – Governing body of Owner.
 - 2.2.4. Contract Negotiations- Discussions which take place between Owner and Apparent Best Value Offeror in an effort to reach agreement on contract scope of work, cost, and other contractual requirements.
 - 2.2.5. Contractor – Successful Offeror to this RFP who enters into a contractual relationship with Owner for completion of Work.
 - 2.2.6. Engineer - Walker Partners, LLC
 - 2.2.7. Issuing Office - Location from which RFP Documents are issued. For this project issuing office is Walker Partners, 804 Las Cimas Parkway, Suite 150, Austin, TX 78746.
 - 2.2.8. Offeror, Offering Firm- Firm which responds to an RFP by submitting a Proposal directly to Owner. Offeror and Offering Firm shall have same meaning in the Instructions to Offerors.
 - 2.2.9. Owner – City of Bastrop.
 - 2.2.10. Proposal- Offeror's submittal which conforms to requirements set forth in this RFP.
 - 2.2.11. Proposal Form- As detailed in requirements of this RFP, contains unit pricing for all parts of Work and their aggregate as detailed and affirmed on Proposal Form and may include additional forms supplied by Offeror and or Owner that relate to Offeror's proposed cost for completing Work.
 - 2.2.12. RFP Document- abbreviation of Request for Proposals Document, document used to request Competitive Sealed Proposals for procurement of goods and services as authorized under Government Code Chapter 2269, Subchapter D.
 - 2.2.13. Statement of Qualifications, (SOQ) - Offeror submitted documents which describe Offering Firm's qualifications for performing Work and contain no pricing or cost data. Requirements for the Statement of Qualifications (SOQ) are set forth in Article 8 and Article 10 of Instructions to Offerors (this RFP).

- 2.2.14. Subcontractor - Any contractor or Supplier hired by Contractor to furnish materials and services specified in this RFP.
 - 2.2.15. Successful Offeror - Firm who has completed negotiations with Owner and may enter into a Contract with Owner to complete Work.
 - 2.2.16. Supplier- Same as Contractor
3. Schedule.
- 3.1 Advertisements: September 26, October 3, 2019, and October 10, 2019
Last Addenda/Addendum Issued: October 22, 2019 at 5:00 PM
Proposal Submission Deadline: October 24, 2019 at 2:00 PM
Anticipated Construction Start: December 2, 2019
4. Request for Proposal Documents/Copies.
- 4.1. This Request for Competitive Sealed Proposals (RFP) consists of the following documents:
 - 4.1.1. Invitation to Submit Proposals (00 11 12);
 - 4.1.2. Instructions to Offerers (00 21 13);
 - 4.1.3. Statement of Qualifications (00 21 14);
 - 4.1.4. Proposal Form (00 41 00);
 - 4.1.5. All Contract Documents referenced in this RFP;
 - 4.1.6. Addenda to this RFP issued by Engineer;
 - 4.1.7. Any attached forms; and
 - 4.1.8. Proposal Security (00 43 13 - Offeror's Bond)
 - 4.2. Complete set of RFP Documents may be accessed at online at CivCast (www.civcastusa.com).
 - 4.3. Complete sets of RFP Documents must be used in preparing Proposals; neither Owner nor Engineer assumes any responsibility for errors or misinterpretations resulting from use of incomplete sets of RFP Documents.
 - 4.4. Owner and Engineer, in making copies of RFP Documents available on above noted terms, do so only for purpose of obtaining Proposals for Work and do not confer a license or grant for any other use.
5. Competitive Sealed Proposal Process/Contract Documents.
- 5.1. All questions about Competitive Sealed Proposal Process or meaning or intent of Contract Documents are to be directed to Engineer.
Contact: Alan Munger, PE
Walker Partners
804 Las Cimas Parkway, Suite 150
Austin, TX 78746
(512) 382-0021
 - 5.2. Any questions submitted to Walker Partners.
 - 5.3. Interpretations or clarifications considered necessary by Engineer in response to such questions will be issued by Addenda. Oral interpretations or clarifications are not binding.
6. Pre- Submittal Conference.
- 6.1. None
7. Estimated Budget.
- 7.1. Engineer's Opinion of Probable Construction Cost (project cost estimate) has been generated by Engineer. If an award is made, actual contract amount may vary.
 - 7.2. Engineer's Opinion of Probable Construction Cost for this project is \$848,000.00.
8. Basis for Ranking of Proposals.
- 8.1. Owner will consider qualifications (Statement of Qualifications) of each Offeror and their respective proposed Contract Price (Proposal Form) when evaluating Proposals to determine which Offeror, in sole opinion of Owner, will provide best value to Owner. All procurements shall conform to Chapter 2269 of State of Texas Government Code. Proposals will be evaluated using the following criteria and weighting:

- 8.1.1. Proposed Project Cost: Offeror's Proposed Cost of Performing Work shall be indicated in Section 00 41 00 – Proposal Form.
- 8.1.2. Experience/Past Performance of Offeror: Provide general information about Organization and a Statement of Qualifications. Include information on similar Projects on which Offeror has had significant involvement in the last five (5) years, or that demonstrate experience with similar Projects. This list is to include name and a current telephone number of references for each of these Project assignments. Offerors are to include a list of current Project assignments for each of individuals proposed, anticipated completion date for this assignment and percentage of time they will have available to devote to this Project.
- 8.1.3. Ability to Meet Proposed Time for Construction: Provide information, which may include a bar chart schedule, to demonstrate a project approach which includes equipment and/or subcontractors to be used and ability to perform work which will meet milestone dates and meet project completion date.
- 8.1.4. Experience/Qualifications of Superintendent: Provide information on Superintendent's qualifications including information on similar Projects on which Superintendent has been in charge of in the last five (5) years, or that demonstrate experience with similar Projects. This list is to include name and a current telephone number of references for each of these assignments. Superintendent must be dedicated to this Project full time for duration of Project and may not be changed without written approval by Engineer. ability of Organization to complete Projects within budget and on time.
- 8.1.5. Other Factors: Owner will consider other factors in evaluating Proposals, including the following:
 - 8.1.5.1. Quality of Work: Demonstrated quality of Work on completed Projects as determined by site visits or discussions with references for Projects. Quality considerations may include appearance of completed Work, amount of warranty or rework required, durability and maintainability of completed Project, and quality of documentation provided.
 - 8.1.5.2. Safety: Demonstrated success in implementation of a site safety program.
 - 8.1.5.3. Claims Experience and Litigation History: Provide a list all claims or litigation involving construction Projects that have been filed by Offeror or Owner within last five (5) years, or that are currently outstanding.

8.2. Table of criteria and weighting for the ranking of Offeror's Proposals.

Category	Description	Weighting Points
1	Proposed Project Cost	50
2	Experience/Past Performance of Offeror with Similar Projects	20
3	Ability to Meet Proposed Budget and Time for Construction	20
4	Experience/Qualifications of Proposed Key Personnel	5
5	Other Factors	5
6	Financial Management (Stability)	Pass/Fail
Total		100

- 9. Proposal Form.
 - 9.1. Proposal Form (00 41 00) is included with RFP Documents.
 - 9.2. All blanks on Proposal Form must be completed in ink, by hand, or electronically printed.
 - 9.3. Proposal price shall include such amount as Offeror deems proper for overhead and profit.
- 10. Offering Firm's Statement of Qualifications (SOQ).
 - 10.1. Provide information required on form Section 00 21 14 - Statement of Qualifications.
- 11. Ranking of Offeror's Proposals.
 - 11.1. Owner will consider qualifications (Statement of Qualifications) of Offerors and Offeror's subcontractors and consultants, in addition to proposed cost(s) (Proposal Form) when evaluating Proposals to determine which Proposal offers best value to Owner. Owner will rank each of Offeror's Proposals based on criteria and criteria weighting described in Article 8, Basis for Ranking of Proposals.

- 11.2. Evaluation and ranking of Proposals will be completed no later than 30th calendar day from date of Proposal opening. Offerors are requested not to withdraw their Proposals within 90 calendar days from date on which Proposals are opened. Proposal Security of highest ranking firms will be held by Owner until contract negotiations are finalized.
 - 11.3. In evaluating Proposals, Owner will consider selection criteria set forth in Article 8 of these Instructions to Offerors and whether or not Proposals comply with the prescribed requirements, and such alternates, unit prices and other data, as may be requested by Owner.
 - 11.4. Owner may consider the qualifications and experience of Subcontractors, Suppliers, and other persons and organizations proposed for those portions of Work, as to which the identity of Subcontractors, Suppliers, and other persons and organizations must be submitted as provided in General Conditions. Owner may also consider the operating costs, maintenance requirements, performance data and guarantees of major items of materials and equipment proposed for incorporation in Work when such data is required to be submitted prior to recommendation of award.
 - 11.5. Owner may conduct such investigations as Owner deems necessary to assist in evaluation of any Proposal and to establish the responsibility, qualifications and financial ability of Offerors, proposed Subcontractors, Suppliers and other persons and organizations to perform and furnish Work in accordance with Contract Documents to Owner's satisfaction within prescribed time.
 - 11.6. Owner, at its discretion, may also choose to conduct interviews with to ranking Offerors to provide Offerors a better opportunity to demonstrate they can provide best value to Owner for this Project. Should Owner choose to conduct interviews with top ranking Offerors, they will be notified of:
 - 11.6.1. Time and place for interview.
 - 11.6.2. Interview format and agenda.
 - 11.6.3. Questions to prepare for interview.
 - 11.6.4. Individuals that are expected to participate in the interview. Failure to participate in interview may result in disqualification from consideration for project.
12. Award of Contract.
 - 12.1. It is intent of Owner to award this contract to Offering Firm whose Proposal for completion of Work provides best value for Owner after consideration of relative importance of costs and other evaluation factors described in Basis for Ranking Offerors set forth in Article 8 of these Instructions to Offerors.
 - 12.2. Owner reserves right to adopt most advantageous interpretation of Proposals submitted in case of ambiguity or lack of clearness in stating Proposal Prices, to reject any or all Proposals, and/or waive informalities.
 - 12.3. Owner reserves right to reject any or all Proposals, including without limitation rights to reject any or all nonconforming, non-responsive, unbalanced, or conditional Proposals and to reject the Proposal of any Offeror if Owner believes that it would not be in best interest of Project to make an award to that Offeror, whether because Proposal is not responsive or Offeror is unqualified or of doubtful financial ability or fails to meet any other pertinent standard or criteria established by Owner.
 - 12.4. Owner also reserves the right to waive all informalities not involving price, time or changes in Work and to negotiate contract terms with Apparent Best Value Offeror. Discrepancies between multiplication of units of Work and unit prices will be resolved in favor of the unit prices. Discrepancies between indicated sum of any column of figures and correct sum thereof will be resolved in favor of correct sum. Discrepancies between words and figures will be resolved in favor of words.
 - 12.5. Qualifications of a firm shall not deprive Owner of right to accept a Proposal, which in its judgment offers best value to Owner. In addition, Owner reserves the right to reject any Proposal where circumstances and developments have, in opinion of Owner, changed qualifications or responsibility of firm.
 - 12.6. Material misstatements in material submitted for evaluation may be ground for rejection of Offeror's Proposal on this project. Any such misstatement, if discovered after award of contract to such firm, may be grounds for immediate termination of contract. Additionally, Offeror will be

9/16

- liable to Owner for any additional costs or damages to Owner resulting from such misstatements, including costs and attorney's fees for collecting such costs and damages.
- 12.7. If Contract is to be awarded, it will be awarded to Apparent Best Value Offeror following successful Contract Negotiations.
 - 12.8. If Contract Negotiations with Apparent Best Value Offeror are unsuccessful, Owner will formally close Contract Negotiations with this Firm and attempt to open Contract Negotiations with next highest-ranked firm according to selection criteria set forth in Article 8 of these Instructions to Offerors.
 - 12.9. If Contract is to be awarded, Owner will notify Successful Offeror of intent to submit contract for approval by Owner within sixty (60) days after day of Proposal opening. Following approval Owner shall execute contract.
 - 12.10. Offeror may submit exceptions or alternatives not in accordance with terms and conditions of Contract Documents, or for Work that is not in strict compliance with Contract Documents. Describe intent and substance of changes in Proposal in adequate detail so they are clearly understood. Alternates will not be considered in ranking and evaluation of Proposals. Upon selection of Proposal that offers the best value to Owner, Owner and Engineer may consider proposed alternates in negotiating a final Contract scope, schedule and price.
 - 12.11. Addenda may be issued to clarify, correct, or change Contract Documents, Addenda or related supplemental data as deemed advisable by Owner or Engineer.
13. Interpretation, Addenda, and Alternate Proposals.
- 13.1. All questions about meaning or intent of Request for Proposal and Contract Documents are to be directed to Engineer in writing. Interpretations or clarifications considered necessary by Engineer in response to such questions will be issued by written Addenda.
 - 13.2. To properly qualify his Proposal, each Offeror shall, prior to submitting his Proposal, check receipt of all Addenda and acknowledge such receipt on Proposal Form and on the acknowledgement line of Addendum Cover page. Proposals submitted without such acknowledgment of all issued Addenda and letters of clarification may cause Proposal to be considered non-responsive. Such Addenda and letters of clarification shall become a part of the executed contract and modify contract documents accordingly.
 - 13.3. Questions received after deadline for Questions and Inquiries may not be answered.
 - 13.4. Only questions answered by formal written Addenda issued by Owner will be binding. Oral and other interpretations or clarifications will be without legal effect.
 - 13.5. Addenda may also be issued to modify RFP Documents as deemed advisable by Owner or Engineer.
 - 13.6. Owner or Engineer will not be held liable for any failure by Engineer for notification to reach Offeror. Offerors are encouraged to contact Engineer after legal limit for filing addenda (48 hours prior to Proposal due date and time) has passed to ensure receipt of all addenda.
14. Confidentiality of Proposal Information.
- 14.1. All materials submitted to Owner will become public property and are subject to Texas Public Information Act, Government Code Chapter 552. If an Offeror does not desire proprietary information in SOQ to be disclosed, each page must be identified and marked proprietary at time of submittal. Owner will, to extent provided by law, endeavor to protect such information from disclosure. Final decision as to what information must be disclosed, however, lies with Texas Attorney General. Failure to identify proprietary information will result in all unmarked sections being deemed non-proprietary and available upon public request. Proposers shall not be permitted to mark entire Proposal as proprietary.
15. Examination of Contract Documents and Site.
- 15.1. It is the sole responsibility of each Offeror before submitting a Proposal:
 - 15.1.1. To examine thoroughly Contract Documents and other related data identified in RFP Documents (including "technical data" referred to below):
 - 15.1.2. To visit Site to become familiar with and satisfy Offeror as to general, local and Site conditions that may affect cost, progress, performance or furnishing of Work;

- 15.1.3. To consider federal, state and local Laws and Regulations that may affect cost, progress, performance or furnishing of Work;
- 15.1.4. To study and carefully correlate Offeror's knowledge and observations with Contract Documents and such other related data; and
- 15.1.5. To promptly notify Engineer of all conflicts, errors, ambiguities or discrepancies which Offeror has discovered in or between Contract Documents and such other related documents.
- 15.2. Information and data shown or indicated in Contract Documents with respect to existing Underground Facilities at or contiguous to Site are based upon information and data furnished to Owner and Engineer by Owners of such Underground Facilities or others, and Owner and Engineer do not assume responsibility for accuracy or completeness thereof or for Offeror's interpretation of such information and data. Contractor is advised to coordinate closely with Owner, Engineer and Utility Operator(s) prior to the commencement of any underground construction activities.
- 15.3. Provisions concerning responsibilities for adequacy of data furnished to prospective Offerors with respect to subsurface conditions, other physical conditions and Underground Facilities, and possible changes in Contract Documents due to differing or unanticipated conditions appear in Article 6 of Agreement and Article 4 of General Conditions.
- 15.4. Before submitting a Proposal, each Offeror will be responsible for obtaining such additional or supplementary examinations, investigations, explorations, tests, studies and data concerning conditions (surface, subsurface and underground facilities) at or contiguous to site or otherwise, which may affect cost, progress, performance or furnishing of Work, or which relate to any aspect of means, methods, techniques, sequences or procedures of construction to be employed by Offeror and safety precautions and programs incident thereto or which Offeror deems necessary to determine its Proposal for performing and furnishing Work in accordance with time, price and other terms and conditions of Contract Documents.
- 15.5. On request, Owner will provide each Offeror access to site to conduct such examinations, investigations, explorations, tests and studies, as each Offeror deems necessary for submission of a Proposal. Offeror must fill any resultant holes and clean up and restore Site to its former condition upon completion of such explorations, investigations, tests, and studies.
- 15.6. Reference is made to Specification Section 01 10 00 - Summary of Work for the identification of general nature of Work that is to be performed at Site by Owner or others (such as utilities and other prime Contractors) that relates to Work for which a Proposal is to be submitted. On request, Owner may provide to each Offeror for examination access to or copies of Contract Documents (other than portions thereof related to price) for such Work.
- 15.7. Submission of a Proposal will constitute an incontrovertible representation by Offeror that Offeror has complied with every requirement of this Article 15, that without exception Proposal is premised upon performing and furnishing Work required by Contract Documents and applying specific means, methods, techniques, sequences or procedures of construction (if any) that may be shown or indicated or expressly required by Contract Documents, that Offeror has given Owner or Engineer written notice of all conflicts, errors, ambiguities and discrepancies that Offeror has discovered in Contract Documents and written resolutions thereof by Engineer is acceptable to Offeror, and that Contract Documents are generally sufficient to indicate and convey understanding of all terms and conditions for performing and furnishing Work.
- 15.8. Provisions of 15.1 through 15.8, inclusive, do not apply to Asbestos, Polychlorinated biphenyls (PCBs), Petroleum, Hazardous Waste or Radioactive Material covered by Article 4.06 of General Conditions.
- 15.9. Addenda may also be issued to modify RFP Documents as deemed advisable by Owner or Engineer.
- 16. Proposal Security.
 - 16.1. Each Proposal must be accompanied by Proposal Security made payable to Owner in the amount not less than five percent (5%) of total Proposal Amount, including any Cash Allowances and Alternates, and shall be in form of a cashier's check or Offeror's Bond.
 - 16.2. Offeror's Bond must be on the form provided within Contract Documents (RFP) and must bear impressed seal of Surety, and be signed by Offeror and an authorized individual of Surety. Bonds

will only be accepted from Sureties authorized to execute a bond order and in accordance with state law.

- 16.3. Proposal Security of Successful Offeror will be retained until such Offeror has executed Agreement, furnished required contract securities and met other conditions contained in Specification Section 00 41 00 – Proposal Form, whereupon Proposal Security will be returned. If Offeror fails to execute and deliver Agreement and furnish required contract security within thirty (30) days after contract award notification, Owner may annul its award and Proposal Security of that Offeror will be forfeited. Proposal Security of other Offerors whom Owner believes to have a reasonable chance of receiving award may be retained by Owner until the earlier of seventh day after Effective Date of Agreement or ninety-first day after Proposal opening, whereupon Proposal Security furnished by such Offerors will be returned. Proposal Security submitted in form of a cashier's check with Proposals which are not competitive will be returned.

17. Contract Times.

- 17.1 Number of days (calendar days) within which, or dates by which, Work is to achieve Substantial and Final Completion are set forth in Section 00 52 00 – Agreement between Owner and Contractor.
- 17.2 Offeror's attention is directed to Special Provision 5 and Sheet C003 of details for additional Schedule requirements.

18. Substitutes and "Or-Equal" Items.

- 18.1 Contract, if awarded, will be on basis of materials and equipment described in Drawings or specified in Specifications with consideration for possible substitute or "or equivalent" items. Whenever it is indicated in Drawings or specified in Specifications that a Substitute or "or-equal"/"or equivalent" item of material or equipment may be furnished or used by Contractor if acceptable to Engineer and Owner, application for such acceptance may be prior to Contract award in accordance with Texas Government Code 2269.155.

19. Subcontractors, Suppliers and Others.

- 19.1. If Owner requests the identity of certain Subcontractors, Suppliers or other persons or organizations (including those who are to furnish the principal items of material and equipment) to be submitted to Apparent Best Value Offeror, and any other Offerors so requested, shall within five (5) days from request submit to Owner a list of all such Subcontractors, Suppliers or other persons or organizations proposed for those portions of Work for which such identification is requested. Such list shall be accompanied by an experience statement with pertinent information regarding similar projects and other evidence of qualification for each such Subcontractor, Supplier, person or organization if requested by Owner. If Owner or Engineer, after due investigation, has reasonable objection to any proposed Subcontractor, Supplier, other person or organization, Owner may, before giving notice of its intent to recommend Award, request that Apparent Best Value Offeror submit an acceptable substitute without an increase in price. If Apparent Best Value Offeror declines to make any such substitution, Owner may formally close contract negotiations with Offeror and enter into contract negotiations with next most highly-ranked Offeror that proposes to use acceptable Subcontractors, Suppliers, and other persons and organizations. Declining to make requested substitutions will not constitute grounds for sacrificing Proposal Security of any Offeror. Any Subcontractor, Supplier, other person or organization listed and to whom Owner or Engineer does not make written objection prior to giving notice of its intent to recommend Award will be deemed acceptable to Owner and Engineer subject to revocation of such acceptance after Effective Date of Agreement as provided in Article 6.06 of General Conditions.
- 19.2. No Contractor shall be required to employ any Subcontractor, Supplier, other person or organization against whom Contractor has reasonable objection.

20. Preparation and of Proposals.

- 20.1. Prepare one (1) unbound original of complete Proposal Package, including completed Proposal Form 00 41 00.

- 20.2. Original Proposal is Proposal containing Original Signature of a person authorized to sign on behalf of Offering Firm.
 - 20.3. Proposals shall be enclosed in an opaque sealed Envelope (or Package), marked with RFP name in addition to name and address of Offering Firm.
 - 20.4. Each Original Proposal submitted by an Offeror shall contain the following:
 - 20.4.1. *Offerors Statement of Qualifications (Form Section 00 21 14 - Statement of Qualifications)*
 - 20.4.2. *Completed Proposal (Form Section 00 41 00 - Proposal)*
 - 20.4.3. *Proposal Security (Form Section 00 43 13 - Offeror's Bond)*
 - 20.4.4. *Project Approach which includes Offeror's proposed schedule for completion of project.*
 - 20.4.5. *Non-Collusion Affidavit (Located in Sample Forms)*
 - 20.5. Proposals submitted by corporations must be executed in corporate name by president or a vice-president (or other corporate officer accompanied by evidence of authority to sign) and corporate seal must be affixed and attested by the secretary or an assistant secretary. Corporate address and state of incorporation must be shown below signature.
 - 20.6. Submitted Proposals by partnerships must be executed in partnership name and signed by a partner, whose title must appear under signature and official address of partnership must be shown below signature.
 - 20.7. All names must be typed or printed in ink below signature.
 - 20.8. Proposal shall contain an acknowledgment of receipt of all Addenda (numbers of which must be filled in on Proposal Form).
 - 20.9. Address and telephone number for communications regarding Proposal must be shown.
 - 20.10. Evidence of authority to conduct business in the State of Texas shall be provided in accordance with 00 41 00 – Proposal Form.
21. Submission of Proposals.
 - 21.1. Proposals shall be submitted at time and place indicated in Invitation to Submit Proposals (00 11 12) and shall be enclosed in an opaque sealed envelope with name and address of Offering Firm and accompanied by Proposal Security and other required documents.
 - 21.2. If Proposal is sent through mail or other delivery system sealed envelope shall be enclosed in a separate envelope with notation "SEALED PROPOSAL ENCLOSED" on face of it. Proposals not received by time or at location specified will be returned unopened to Offeror.
 - 21.3. Clock used by Owner at place used for receiving Proposals shall conclusively determine time that Proposals are received.
 - 21.4. Proposals sent by facsimile or electronic mail or delivered to any other location other than address provided in Invitation to Offerors will NOT be accepted.
 22. Modification and Withdrawal of Proposals.
 - 22.1. Proposals may be modified or withdrawn by a document duly executed (in same manner that a Proposal must be executed) and delivered to place where Proposals are to be submitted prior to date and time for opening of Proposals.
 - 22.2. If, within twenty-four (24) hours after Proposals are opened, any Offeror files a duly signed written notice with Owner and promptly thereafter demonstrates to reasonable satisfaction of Owner that there was a material or substantial mistake in preparation of its Proposal, that Offeror may withdraw its Proposal. Proposal Security may be retained by Owner if Offeror cannot clearly demonstrate to Owner evidence of a material or substantial mistake in its Proposal. Thereafter, that Offeror may be disqualified from responding to a reissued RFP for Work to be furnished under these Contract Documents.
 23. Opening of Proposals.
 - 23.1. Proposals will be opened and (unless obviously non-responsive) names and Monetary Proposals of Offering Firms read aloud at a public opening. An abstract of Proposals will be made available no later than seventh day after Contract is awarded.
 24. Proposals to Remain Subject to Acceptance.

- 24.1 All Proposals will remain subject to acceptance for ninety days (90) after date of opening, but Owner may, in its sole discretion, release any Proposal and return Proposal Security prior to that date.
25. Prevailing Wage Rates.
25.1 Contractors for this Project must pay no less than prevailing wage rates for area.
26. Liquidated Damages.
26.1 Provisions for liquidated damages are set forth in specification section 00 52 00 – Agreement between Owner and Contractor and specification section 00 72 15 - General Conditions of the Contract.
27. Contract Security and Insurance.
27.1 Article 5 of General Conditions sets forth Owner's requirements as to insurance(s) and Performance and Payment Bonds. When Successful Offeror delivers executed Agreement to Owner, it must be accompanied by required insurances, Performance and Payment Bonds. Insurances shall include all required certificates and/or endorsements.
28. Conflict of Interest.
28.1 Chapter 176 of Texas Local Government Code mandates public disclosure of certain information concerning persons doing business or seeking to do business with Owner, including affiliations and business and financial relationships such persons may have with Owner. An explanation of requirements of Chapter 176, applicable forms and a complete text of this law are available at: <http://www.ethics.state.tx.us/forms/CIQ.pdf>. BY DOING BUSINESS OR SEEKING TO DO BUSINESS WITH OWNER, YOU ACKNOWLEDGE THAT YOU HAVE BEEN NOTIFIED OF REQUIREMENTS OF CHAPTER 176 OF TEXAS LOCAL GOVERNMENT CODE AND THAT YOU ARE SOLELY RESPONSIBLE FOR COMPLYING WITH THEM.
29. Taxes.
29.1 Owner is exempt from payment of sales and compensating use taxes of State of Texas and of cities and counties thereof on all materials to be incorporated into Work. Owner will furnish required certificates of tax exemption to Contractor for use in purchase of supplies and materials to be incorporated into Work.
29.2. Owner's exemption does not apply to construction tools, machinery, equipment, or other property purchased by or leased by Contractor, or to supplies or materials not incorporated into Work.
29.3. Sales and Use Tax: Owner is exempt from Texas state sales and use taxes on materials and equipment to be incorporated into Work. Said taxes shall not be included in Proposal.
30. Signing of Agreement.
30.1 Owner will transmit to Successful Offeror required number of unsigned counterparts of Agreement with all other written Contract Documents attached. Contractor shall sign and deliver required number of counterparts of Agreement and written Contract Documents to Owner thirty (30) days.

END OF SECTION

SECTION 00 21 14

STATEMENT OF QUALIFICATIONS

TABLE 1 - GENERAL INFORMATION			
A. COMPANY DATA			
Organization Doing Business:	Angel Brothers Enterprises, Ltd.		
Business Address:	23990 Stark Highway, Ne Nassau, TX 77868		
Telephone Number:	936-825-0118		
Fax Number:	N/A		
Form of Business:	Corporation	Partnership <input checked="" type="checkbox"/>	Individual <input type="checkbox"/> Joint Venture <input type="checkbox"/>
IF A CORPORATION			
Date of Incorporation:			
State Incorporated:			
President's Name:			
Vice President's Name:			
IF A PARTNERSHIP			
Date of Organization:	1972		
Type	General <input type="checkbox"/>	Limited <input checked="" type="checkbox"/>	
IF AN INDIVIDUAL			
Name:			
Business Address:			
IF A JOINT VENTURE			
Name of Manager:			
Name of Firm:			
Name of Individual Companies:			
B. BUSINESS INFORMATION			
Current Number of Full Time Employees:	1,200+	Past Year's Revenues:	\$250,000,000+
Average Number of Projects Annually:	100	Average Construction Cost of Project:	\$2,500,000
C. DIVISION OF WORK BETWEEN CONTRACTOR AND SUBCONTRACTORS			
1. List work that will be provided by Offeror (Prime Contractor) using its own resources.			
Base Repair, Seal Coat, TOM Overlay Alternate			
2. List work that will be provided by Subcontractors on this project.			
Fog Seal, Scrub Seal, Frictional Asphaltic Surface Preservation Treatment, Joint Seal			

AS

TABLE 2 - CONSTRUCTION EXPERIENCE			
1. Years of experience:			
a. with Seal Coat Projects;			
b. with Scrub Seal Projects;			
c. with Frictional Asphaltic Surface Preservation;			
d. with Flexible Pavement Repair Projects.			
As a General Contractor:	a. + d.	Number of Total Projects:	500+
2. Number of Seal Coat and/or Frictional Asphaltic Preservation Treatment projects completed in State of Texas in the past five (5) years?			Seal Coat - 50+ FAPT - 0
3. Has this or a predecessor company ever defaulted on a project or failed to complete work award to it?			No
4. Has this or a predecessor company ever been released from a bid or proposal in the past ten (10) years?			No
5. Has this or a predecessor company ever been disqualified as a bidder or offeror on any project within the last five (5) years?			No
6. Is offering company currently involved in any litigation or contemplating any litigation?			No
7. Has this or a predecessor company ever refused to construct or refused to provide materials defined in Contract Documents on a project?			No
8. Are there any liens currently filed against the offeror by either subcontractor or material suppliers on previous projects?			No

TABLE 3 - PROPOSED KEY PERSONNEL	
PROJECT MANAGER	
Name of Project Manager	Kyle Lewis
Years of Experience as PM	20
Number of Similar Projects as PM with this company	100+
Number of Similar Projects with other companies (PM)	250+
Current Assignments	
% of time dedicated to this project	25%
Reference Project	
Project Name: Bastrop US 290	Reference Name: Willie Senora
Title: Assistant Area Engineer	Organization: TXDOT
Telephone Number: 512-321-2195	Email: William.Senora@txdot.gov
PROJECT SUPERINTENDENT	
Name of Superintendent	John Delibert
Years of Experience as Superintendent	10+
Number of Similar Projects as Super with this company	50+
Number of Similar Project with other companies (Super)	0
Current Assignments	
% of time dedicated to this project	100%
Reference Project	
Project Name: Bastrop US 290	Reference Name: Willie Senora
Title: Assistant Area Engineer	Organization: TXDOT
Telephone Number: 512-321-2195	Email: William.Senora@txdot.gov

ax

TABLE 4 - SIMILAR PROJECTS COMPLETED WITHIN LAST 5 YEARS				
REFERENCE PROJECT 1				
Project Description				
Austin County Old Highway 36				
Owner	Project Name	Contract Amount	Date Completed	% Change Orders
Austin County	Old Hwy 36	2,465,180.15	9/30/17	-35.71%
Owner's Reference Information				
Name	Title	Organization	Telephone	E-Mail
Tim Laphan	County Judge	Austin County	979-270-1393	
Engineer's Reference Information				
Name	Title	Company	Telephone	E-Mail
Charles Kalkomey	Project Engineer	Pledge-Kalkomey	713-542-3141	
REFERENCE PROJECT 2				
Project Description				
City of Thwall 2017 Street Improvements				
Owner	Project Name	Contract Amount	Date Completed	% Change Orders
City of Thwall	2017 Street Imp.	1,005,237.35	8/30/18	15.51%
Owner's Reference Information				
Name	Title	Organization	Telephone	E-Mail
Troy Marx	Mayor	City of Thwall		
Engineer's Reference Information				
Name	Title	Company	Telephone	E-Mail
Dan Hejl	Owner-Engineer	Hejl, Lee & Assoc.	512-751-2226	hlainc@austin.tx.gov
REFERENCE PROJECT 3				
Project Description				
Bastrop US 290 - Paige to McDade				
Owner	Project Name	Contract Amount	Date Completed	% Change Orders
TXDOT	Bastrop US 290	19,049,776.58	2/27/17	7.37%
Owner's Reference Information				
Name	Title	Organization	Telephone	E-Mail
Diana Schulze	Area Engineer	TXDOT	512-321-2195	diana.schulze@txdot.gov
Engineer's Reference Information				
Name	Title	Company	Telephone	E-Mail
Diana Schulze	Area Engineer	TXDOT	512-321-2195	diana.schulze@txdot.gov

24

TABLE 5 - SUBCONTRACTORS AND SUPPLIERS		
PROJECT SPECIFIC SUBCONTRACTORS (greater than 10% of work)		
Name	Work to be Provided	% of Contract
Clark Construction	Fog Seal, Scrub Seal, Friction/Appl. H ₂ O Surf Pres. Treat.	22.16%
Provide a list of major equipment or material suppliers for use on project.		
Supplier Name	Material or Equipment Supplied	
Century Asphalt	Hotmix	
Martin Asphalt	Seal Coat Oil	
Vulcan Materials	Seal Coat Rock	

96

AFFIDAVIT

State Texas

County of Brazos

Kyle Lewis, being duly sworn deposes and attests that he/she is

Vice President (name) and is a duly authorized representative of the Offeror
(title)

submitting the foregoing Section 00 21 14 – Statement of Qualifications and related information, that he/she has read such documents, that he/she is authorized to submit such information on behalf of the Offeror, and that such documents are true and correct and contain no factual errors or material misrepresentations.

Signature

Signed and sworn to me before this 24th day of October, 2019.

Esmeralda Delgado
Notary Public

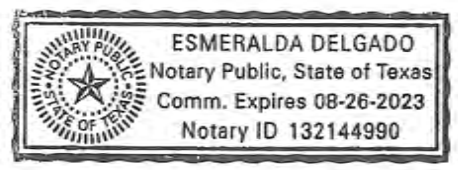

My Commission expires: 08/26/2023



SECTION 00 41 00

PROPOSAL FORM

To: City of Bastrop
1311 Chestnut Street
Bastrop, TX 78602

Project: City of Bastrop – Streets, Pavement, and Preventative Maintenance

RFP No.: 20-001

Offerer: Angel Brothers Enterprises, Ltd.
(Print or type full name of proprietorship, partnership, corporation, or joint venture)

1.0 OFFER

- A. Total Proposal Price: Undersigned Offerer proposes and agrees, if this Proposal is accepted, to enter into an Agreement with Owner on form included in Contract Documents to perform all Work as specified or indicated in Contract Documents for Contract Price indicated in this Proposal or as modified by written Amendment.
- B. Proposal Security: Included with the Proposal is a Proposal Security in amount of 5% of Total Proposal Price subject to terms described in Document 00 21 13 – Instructions to Offerers.
- C. Period for Proposal Acceptance: Offerer accepts all of terms and conditions of Request for Proposals and Instructions to Offerers, including without limitation those dealing with disposition of required Bonds. This offer shall remain open to acceptance and is irrevocable for 90 days from Proposal Date (opening). That period may be extended by mutual written agreement of Owner and Offerer.
- D. Liquidated Damages: Offerer accepts the provisions of Agreement as to liquidated damages in the event of its failure to complete Work in accordance with schedule as set forth in Agreement.
- E. Addenda: Offerer hereby acknowledges it has received, examined and carefully studied all Addenda and modifications to Proposal Documents have been considered and all related costs are included in Total Proposal Price. Offerer hereby acknowledges receipt of the following Addenda:
- F. Proposal Supplements: The following documents shall be provided with proposal:
 - Offerer's Statement of Qualifications (SOQ),
 - Completed Certification of Proposal
 - Proposal Security
 - Project Approach (to include Proposed Schedule for Completion)
 - Non-Collusion Affidavit

2.0 CONTRACT TIME

- A. If offer is accepted, Contractor shall achieve Date of Substantial Completion and Date of Final Completion within Contract Times prescribed in Article 3 of Section 00 52 00 - Agreement Between Owner and Contractor, subject to adjustments of Contract Time as provided in Contract.

3.0 OFFERER REPRESENTATIONS

- A. Offerer is familiar with and is satisfied as to all federal, state and local Laws and Regulations that may affect cost, progress and furnishing of Goods and Special Services.

- B. Offerer has visited Site and become familiar with and is satisfied as to general, local and Site conditions that may affect cost, progress, and performance of Work.
 - C. Intentionally left blank.
 - D. Intentionally left blank.
 - E. Offerer does not consider that any further examinations, investigations, explorations, tests, studies, or data are necessary for the determination of this Proposal for performance of Work at the Contract Price proposed, within Contract Times proposed and in accordance with terms and conditions of Contract Documents.
 - F. Offerer is aware of general nature of work to be performed by Owner and others at Site that relates to Work as indicated in the Contract Documents.
 - G. Offerer has correlated information known to Offerer, information and observations obtained from visits to Site, reports and drawings identified in Contract Documents, and all additional examinations, investigations, explorations, tests, studies, and data with Contract Documents.
 - H. Offerer has given Owner written notice of all conflicts, errors, ambiguities, or discrepancies that Offerer has discovered in Contract Documents, and written resolution thereof by Owner or Engineer is acceptable to Offerer.
 - I. Contract Documents are generally sufficient to indicate and convey understanding of all terms and conditions for the performance of Work for which this Proposal is submitted.
 - J. Laws to be Observed: In execution of Contract, Contractor must comply with all applicable Federal, State, and Local laws, including, but not limited to laws concerned with labor, safety, minimum wages, and environment. Contractor will make himself familiar with and shall at all times observe and comply with all Federal, State, and Local laws, ordinances and regulations which in any manner affect the conduct of the work, and shall indemnify and save harmless the Owner and its representatives against any claim arising from violation of any such law, ordinance or regulation by himself or by his subcontractor or by his employees.
 - K. Review by Owner: Owner and authorized representatives and agents of owner shall at all times have access to and be permitted to observe and review all work, materials, equipment, payrolls, personnel records, employment conditions, material invoices, and other relevant data and records pertaining to this Contract.
 - L. Offerer will submit written evidence of its authority to do business in State of Texas.
 - M. Offerer further represents that this Proposal is genuine and not made in interest of or on behalf of any undisclosed individual or entity and is not submitted in conformity with any agreement or rules of any group, association, organization or corporation; Offerer has not directly or indirectly induced or solicited any other Offerer to submit a false or sham Proposal; Offerer has not solicited or induced any individual or entity to refrain from making an offer; and Offerer has not sought by collusion to obtain for itself any advantage over any other Offerer or over Owner.
- 4.0 DEFINED TERMS:
- A. Defined terms used in this Proposal, if any, shall be for purposes of this Proposal and shall not change any meanings indicated in General Conditions. Significance of terms with initial capital letters is defined in General Conditions.
- 5.0 TOTAL PROPOSAL PRICE HAS BEEN CALCULATED BY OFFERER, USING THE FOLLOWING COMPONENT PRICES AND PROCESS (PRINT OR TYPE NUMERICAL AMOUNTS):

CITY OF BASTROP
STREETS, PAVEMENT, AND PREVENTATIVE MAINTENANCE
PROPOSAL TABULATION

Item	Reference	Description	Quantity	Unit	Unit Price	Total Amount
1.00 General Conditions						
1.01	WP - 01 21 00	MOBILIZATION & PROJECT INCIDENTALS	1	LS	110,000. ⁰⁰	110,000. ⁰⁰
1.02	COA 802S-BC.I.P.	PROJECT SIGNS	4	EA	1,000. ⁰⁰	4,000. ⁰⁰
1.03	Project Notes	TRAFFIC CONTROL PLAN	1	LS	2,000. ⁰⁰	2,000. ⁰⁰
1.04	Project Notes	TRAFFIC CONTROL PLAN - IMPLEMENTATION	1	LS	20,000. ⁰⁰	20,000. ⁰⁰
1.05	WP - 01 30 00	CONTINGENCY ALLOWANCE	1	LS	\$45,000.00	\$45,000.00
1.06	WP - 33 01 31	MANHOLE GRADE ADJUSTMENT	7	EA	1,500. ⁰⁰	10,500. ⁰⁰
Subtotal General Conditions						191,500. ⁰⁰
2.00 Street Maintenance						
Maintenance Treatments						
2.01	TxDOT 351	5" FLEXIBLE PAVEMENT REPAIR WITH TYPE B HMAC (PG 64-22)	7,908	SY	63. ⁰⁰	498,204. ⁰⁰
2.02	TxDOT 712	JT / CRCK SEAL (RUBBER - ASPHALT)	36.00	L-MI	1,200. ⁰⁰	43,200. ⁰⁰
Preventative Maintenance Surface Treatments						
2.03	TxDOT 315	FOG SEAL (CMS-1PF)(0.09 gal/SY)	26,604	SY	2.20	58,528. ⁸⁰
2.04	TxDOT 316	SEAL COAT TREATMENT (AC20-5TR W/ GR 4 PB TRAP ROCK)(0.40 GAL/SY and 1 CY/110 SY)	41,728	SY	4.10	171,084. ⁸⁰
2.05	TxDOT 3005	SCRUB SEAL TREATMENT (CMS-2P with GR 4 TRAP ROCK)(0.48 GAL/SY and 1 CY/110 SY)	17,590	SY	6.10	107,299. ⁰⁰
2.06	TxDOT 3028	FRICTIONAL ASPHALTIC SURFACE PRESERVATION TREATMENT	24,859	SY	4. ⁸⁰	119,323. ²⁰
Alternate Bid Item #1						
2.04 A	TxDOT 347	THIN OVERLAY MIXTURE (PG 70-22)(1" THICKNESS) in Lieu of SEAL COAT TREATMENT	41,728	SY	7.40	308,787. ²⁰
Subtotal Street Maintenance						997,639. ⁸⁰

Total Bid Price

Base Bid 997,639.⁸⁰
 Alternate (Deduct 2.04, add 2.04A) 1,135,342.²⁰
 Base Bid: \$1,189,139.⁸⁰
 Total w/Alternate: \$1,326,842.²⁰

6.0 ADDENDA

Following Addenda have been received by Offerer. Modifications to Proposal Documents noted below have been considered and all costs are included in Proposal Price.

Addendum # N/A Dated N/A

Addendum # Dated

Addendum # Dated

Addendum # Dated

Addendum # Dated

Addendum # Dated

7.0 PROPOSAL FORM SIGNATURES*

This Proposal is submitted by:

Angel Brothers Enterprises, Ltd.

(Offerer - print the full name of firm submitting Proposal)**

was hereunto affixed in the presence of:

Name and Title (printed or typed) Kyle Lewis, Vice President

By: [Signature]
(Authorized signing officer signature)

(Seal)

Person with Offerer authorized to discuss contents of Proposal and Qualifications:

David Deksandri or Kyle Lewis

Phone Number: 903-390-6895 or 281-300-5194

* If Proposal is a joint venture, add additional Proposal Form signature sheets for each member of joint venture.

** Offerer certifies that only person or parties interested in this offer as principals are those named above. Offerer has not directly or indirectly entered into any agreement, participated in any collusion, or otherwise taken any action in restraint of free competitive Proposing.

Note: This document constitutes a government record, as defined by § 37.01 of Texas Penal Code. Submission of a false government record is punishable as provided in § 37.10 of Texas Penal Code.

END OF SECTION

A

SECTION 00 43 13

OFFERER'S BOND

THAT WE, Angel Brothers Enterprises, Ltd., as Principal, ("Offerer"), and the other subscriber hereto, Liberty Mutual Fire Insurance Company as Surety, do hereby acknowledge ourselves to be held and firmly bound to City of Bastrop, ("Owner") a political sub-division of the State of Texas, in the sum of Five Percent of the Greatest Amount Bid Dollars (\$ 5% G.A.B.) an amount equal to five (5) percent of the Total Bid Price, including Cash Allowances and Alternates, if any, for payment of which sum, well and truly to be made to Owner and its successors, Offerer and Surety do bind themselves, their heirs, executors, administrators, successors, and assigns, jointly and severally.

CONDITIONS OF THIS OBLIGATION ARE SUCH THAT: WHEREAS, Offerer has submitted on or about this day a proposal offering to perform the following:

RFP No. 20-001 City of Bastrop – Streets, Pavement, and Preventative Maintenance in accordance with Drawings, Specifications, and terms and conditions related thereto to which reference is hereby made.

NOW, THEREFORE, if Offerer's offer as stated in Document 00 41 00 – Proposal Form is accepted by Owner, and Offerer executes and returns to Owner executed Section 00 52 00 – Agreement on forms provided in Proposal Documents, for Work and also executes and returns same number of Performance, Payment, and Maintenance Bonds (such bonds to be executed by a Corporate Surety authorized by State Board of Insurance to conduct insurance business in the State of Texas, and having an underwriting limitation in at least the amount of bond) and other submittals as required, in connection with Work, within allotted Contract Time, then this obligation shall become null and void; otherwise it is to remain in full force and effect.

If Offerer is unable to or fails to perform its obligations undertaken herein, the undersigned Offerer and Surety shall be liable to Owner for full amount of this obligation which is hereby acknowledged as amount of damages which will be suffered by Owner on account of failure of such Offerer to perform such obligations, the actual amount of such damages being difficult to ascertain. Notices required or permitted hereunder shall be in writing and shall be deemed delivered when actually received or, if earlier, on third day following deposit in a United States Postal Service post office or receptacle, with proper postage affixed (certified mail, return receipt requested), addressed to respective other Party at address prescribed in Contract Documents, or at such other address as receiving Party may hereafter prescribe by written notice to sending Party.

IN WITNESS THEREOF, both Offerer and Surety have signed and sealed this instrument on the respective dates written below their signatures and have attached current Power of Attorney.

ATTEST, SEAL: (if a corporation)

OFFERER

SURETY

Angel Brothers Enterprises, Ltd. (Seal)
Bidder's Name and Corporate Seal

Liberty Mutual Fire Insurance Company (Seal)
Surety's Name and Corporate Seal

By: 
Signature and Title Vice President
Kyle Lewis

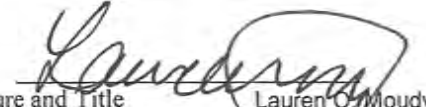
By: 
Signature and Title Lauren O'Moody
(Attach Power of Attorney) Attorney in Fact
October 24, 2019

Attest: 
Signature and Title Project manager
David Delesardi

Attest: 
Signature and Title Heather Noles
Witness
October 24, 2019

END OF SECTION





This Power of Attorney limits the acts of those named herein, and they have no authority to bind the Company except in the manner and to the extent herein stated.

Liberty Mutual Fire Insurance Company
Wausau, Wisconsin

Certificate No: 8201247

POWER OF ATTORNEY

KNOWN ALL PERSONS BY THESE PRESENTS: Liberty Mutual Fire Insurance Company, being a Wisconsin Corporation having its principal office in the City of Wausau, State of Wisconsin does hereby make, constitute and appoint Ashley Britt Platt, Alyson Carmichael, Robert C. Davis, Tabitha Dorman, Nikole Jeannette, Kristi Lovett, Barry K. McCord, David T. Miclette, Lauren O. Moudy, Heather Noles, Robert M. Overbey, Jr.

all of the city of Houston state of TX each individually if there be more than one named, its true and lawful attorney(s)-in-fact, with full power and authority hereby conferred in their/its name, place and stead, to sign, execute, acknowledge and deliver in their/its behalf, and as their/its act and deed, without power of redelegation, as follows:

bonds, undertakings, recognizances, contracts of indemnity, and all other surety obligations, as required, unlimited as to Dollar amount

and to bind the Company(ies) making this appointment thereby as fully and to the same extent as if such bond or undertaking was signed by the duly authorized officers of the Company(ies), and all the acts of said attorney(s), pursuant to the authority herein given, are hereby ratified and confirmed.

AUTHORITY FOR MAKING APPOINTMENT OF ATTORNEYS-IN-FACT

Appointment of Attorneys-in-Fact by Liberty Mutual Fire Insurance Company are made pursuant to Article V, Section 10 of Liberty Mutual Fire Insurance Company's By-Laws, as amended and by Unanimous Consent of the Board of Directors dated May 21st, 2013. Further, the President of Liberty Mutual Fire Insurance Company, executed a Delegation of Authority and authorized the assistant secretary signing below to appoint attorneys-in-fact as may be necessary to act on behalf of Liberty Mutual Fire Insurance Company to make execute, seal, acknowledge and deliver as surety any and all undertakings, bonds, recognizances, and other surety obligations.

IN WITNESS WHEREOF, Liberty Mutual Fire Insurance Company has caused these presents to be signed by its authorized representatives, and its Corporate Seal to be hereto affixed, this 10th day of May, 2019.



Liberty Mutual Fire Insurance Company

By: David M. Carey
David M. Carey, Assistant Secretary

Attest: Lisa Love
Lisa Love

State of PENNSYLVANIA
County of MONTGOMERY ss

The foregoing instrument was acknowledged before me this 10th day of May, 2019 by David M. Carey, an authorized representative of Liberty Mutual Fire Insurance Company.



COMMONWEALTH OF PENNSYLVANIA
Notarial Seal
Teresa Pastella, Notary Public
Upper Merion Twp., Montgomery County
My Commission Expires March 28, 2021
Member, Pennsylvania Association of Notaries

By: Teresa Pastella
Teresa Pastella, Notary Public

To confirm the validity of this Power of Attorney call 1-610-832-8240 between 9:00 am and 4:30 pm EST on any business day.

Not valid for mortgage, note, loan, letter of credit, currency rate, interest rate or residual value guarantees.

CERTIFICATE

I, the undersigned, an Assistant Secretary of Liberty Mutual Fire Insurance Company, do hereby certify that the original power of attorney of which the foregoing is a full, true and correct copy, is in full force and effect on the date of this certificate; and I do further certify that the officer or official who executed the said power of attorney was one of the officers or officials specially authorized by the Board of Directors to appoint attorneys-in-fact as provided in the Unanimous Consent and Vote of the Board of Directors of Liberty Mutual Fire Insurance Company dated May 21, 2013.

This certificate and the above power of attorney may be signed by facsimile or mechanically reproduced signatures under and by authority of the Board of Directors of Liberty Mutual Fire Insurance Company evidenced by the Unanimous Consent and Vote of the Board of Directors dated June 28, 2006 wherein it was

VOTED that the signatures of such officers and the seal of the Company may be affixed to any such power of attorney or to any certificate relating thereto by facsimile, and any such power of attorney or certificate bearing such facsimile signature and facsimile seal shall be valid and binding upon the Company when so affixed and in the future with respect to any surety undertakings, bonds, recognizances and other surety obligations to which it is attached.

IN TESTIMONY WHEREOF, I have hereunto subscribed my name and affixed the corporate seal of the said company, affixed, this 24th day of October, 2019



By: Renee C. Llewellyn
Renee C. Llewellyn, Assistant Secretary

gt



TEXAS
IMPORTANT NOTICE

To obtain information or make a complaint:

You may call toll-free for information or to make a complaint at
1-877-751-2640

You may also write to:

2200 Renaissance Blvd., Ste. 400
King of Prussia, PA 19406-2755

You may contact the Texas Department of Insurance to obtain information on companies, coverages, rights or complaints at
1-800-252-3439

You may write the Texas Department of Insurance Consumer Protection (111-1A)
P. O. Box 149091
Austin, TX 78714-9091
FAX: (512) 490-1007
Web: <http://www.tdi.texas.gov>
E-mail: ConsumerProtection@tdi.texas.gov

PREMIUM OR CLAIM DISPUTES:

Should you have a dispute concerning your premium or about a claim you should first contact the agent or call 1-800-843-6446. If the dispute is not resolved, you may contact the Texas Department of Insurance.

ATTACH THIS NOTICE TO YOUR
POLICY:

This notice is for information only and does not become a part or condition of the attached document.

TEXAS
AVISO IMPORTANTE

Para obtener informacion o para someter una queja:

Usted puede llamar al numero de telefono gratis para informacion o para someter una queja al
1-877-751-2640

Usted tambien puede escribir a:

2200 Renaissance Blvd., Ste. 400
King of Prussia, PA 19406-2755

Puede comunicarse con el Departamento de Seguros de Texas para obtener informacion acerca de companias, coberturas, derechos o quejas al
1-800-252-3439

Puede escribir al Departamento de Seguros de Texas Consumer Protection (111-1A)
P. O. Box 149091
Austin, TX 78714-9091
FAX # (512) 490-1007
Web: <http://www.tdi.texas.gov>
E-mail: ConsumerProtection@tdi.texas.gov

DISPUTAS SOBRE PRIMAS O RECLAMOS:

Si tiene una disputa concerniente a su prima o a un reclamo, debe comunicarse con el agente o primero. Si no se resuelve la disputa, puede entonces comunicarse con el departamento (TDI)

UNA ESTE AVISO A SU POLIZA:

Este aviso es solo para proposito de informacion y no se convierte en parte o condicion del documento adjunto.

A handwritten signature in blue ink, possibly reading "P. H.", is located at the bottom center of the page.

Activity ID	Activity Name	2020			April 2020			May 2020			June 2020			July 2020			
		16	23	30	06	13	20	27	04	11	18	25	01	08	15	22	29

City of Bastrop 10-24	
A1000	Mob/Set Barricades
A1010	Base Repairs
A1020	Adjust Manhole
A1030	Crack Seal
A1035	Awaiting Favorable Weather Conditions
A1040	Fog Seal
A1050	Frictional Asphalt Surface
A1060	Scrub Seal
A1070	Seal Coat/ TOM

Ad

Notice of Award

Dated November 26, 2019

Project: Streets, Pavement, and Preventative Maintenance	Owner: City of Bastrop	Owner's Contract No.:
Contract: City of Bastrop - Streets, Pavement, and Preventative Maintenance		Engineer's Project No.: 4-01126
Bidder: Angel Brothers Enterprises, Ltd.		
Bidder's Address: 23990 State Hwy 6, Navasota, TX 77868		

You are notified that your Bid dated for the above Contract has been considered. You are the Successful Bidder and are awarded a Contract for the Base Proposal Amount for the City of Bastrop - Streets Pavement, and Preventative Maintenance, to include flexible pavement repair, joint and crack seal, and seal coat treatment.

(Indicate total Work, alternates or sections or Work awarded.)

The Contract Price of your Contract is one million, one hundred eighty-nine thousand, one hundred thirty-nine dollars and eighty cents (\$1,189,139.80).

3 copies of each of the proposed Contract Documents (except Drawings) accompany this Notice of Award.

2 sets of the Drawings will be delivered separately or otherwise made available to you immediately.

You must comply with the following conditions precedent within [15] days of the date you receive this Notice of Award.

1. Deliver to the Owner [3] fully executed counterparts of the Contract Documents.
2. Deliver with the executed Contract Documents the Contract security [Bonds] as specified in the Instructions to Bidders (Article 20), [and] General Conditions (Paragraph 5.01).
3. Other conditions precedent:

Failure to comply with these conditions within the time specified will entitle Owner to consider you in default, annul this Notice of Award and declare your Bid security forfeited.

Within ten days after you comply with the above conditions, Owner will return to you one fully executed counterpart of the Contract Documents.

City of Bastrop
Owner
By: _____
Authorized Signature

City Manager
Title

Copy to Engineer

Ab

Notice to Proceed

Dated _____

Project: Streets, Pavement, and Preventative Maintenance	Owner: City of Bastrop	Owner's Contract No.:
Contract: City of Bastrop - Streets, Pavement, and Preventative Maintenance		Engineer's Project No.: 4-01126

Contractor: Angel Brothers Enterprises, Ltd.

Contractor's Address: 23990 State Hwy 6, Navasota, TX 77868

You are notified that the Contract Times under the above contract will commence to run on _____ . On or before that date, you are to start performing your obligations under the Contract Documents. In accordance with Article 3 of the Agreement, the number of days to achieve Substantial Completion is 210, and the number of days to achieve readiness for final payment is 240.

Before you may start any Work at the Site, Paragraph 2.01.B of the General Conditions provides that you and Owner must each deliver to the other (with copies to Engineer and other identified additional insureds) certificates of insurance which each is required to purchase and maintain in accordance with the Contract Documents.

Also, before you may start any Work at the Site, you must:

- 1.0 The contractor shall call the Texas One-Call System @ 1-800-344-8377 at least 48 hours prior to digging.
- 2.0 Prepare a Traffic Control Plan. Prepare and submit to Project Manager for approval as prescribed in the Technical Specifications.

Angel Brothers Enterprises, Ltd.

City of Bastrop

Contractor
Received by: 
Authorized Signature
Vice President
Title
12/16/19
Date

Owner
Given by: 
Authorized Signature
Acting City Manager
Title
12-23-19
Date

Copy to Engineer

OK

SECTION 00 52 00

AGREEMENT

THIS AGREEMENT is dated as of by and between City of Bastrop (hereinafter called "OWNER") and Angel Brothers Enterprises, Ltd. (hereinafter called "CONTRACTOR"). OWNER and CONTRACTOR, in consideration of covenants hereinafter set forth, agree as follows:

- ARTICLE 1. WORK. CONTRACTOR shall complete all Work as specified or indicated in Contract Documents. Work is generally described as follows:
- RFP No. 20-001 City of Bastrop – Streets, Pavement, and Preventative Maintenance in accordance with Drawings, Specifications, and terms and conditions related thereto to which reference is hereby made.
- ARTICLE 2. ENGINEER AND OWNER'S REPRESENTATIVE. Project has been designed by Walker Partners, 804 Las Cimas Parkway, Suite 150, Austin, TX 78746 who is hereinafter called "ENGINEER" and who assumes all duties and responsibilities and has rights and authority assigned to ENGINEER in Contract Documents in connection with completion of Work in accordance with Contract Documents. Owner's Representative for Project shall be Walker Partners, LLC.
- ARTICLE 3. CONTRACT TIMES. Work will be Substantially Completed within 210 calendar days after date when Contract Time Requirements commence to run as provided in Article 2.03 of General Conditions, and CONTRACTOR shall achieve Final Completion within 30 calendar days of date required for Substantial Completion. OWNER and CONTRACTOR recognize that time is of essence of this Agreement and that OWNER will suffer financial loss including, but not limited to, loss of revenue, additional professional fees, fines, labor costs, insurance premiums, etc. if the Work is not completed within times specified in above paragraph, plus any extensions thereof allowed in accordance with Article 12 of General Conditions. They also recognize delays, expense and difficulties involved in proving actual loss suffered by OWNER if the Work is not completed on time. Accordingly, instead of requiring any such proof, OWNER and CONTRACTOR agree that as liquidated damages for delay (but not as a penalty) and, as a reasonable estimate of such damages, CONTRACTOR shall pay OWNER Five Hundred Dollars (\$500.00) for each and every day of delay in CONTRACTOR achieving Substantial Completion of Work and readiness for final payment beyond times specified in above paragraph. OWNER shall have option of deducting the amount of any liquidated damages from any monies that may be owed to CONTRACTOR or to recover such amount from CONTRACTOR or its sureties, at CONTRACTOR'S expense.
- ARTICLE 4. CONTRACT AMOUNT. OWNER shall pay CONTRACTOR for completion of Work in accordance with Contract Documents an amount in current funds equal to sum of amounts determined pursuant to Proposal and any subsequent Change Orders and Change Directives thereto in the amount of one million, one hundred eighty-nine thousand, one hundred thirty-nine dollars and eighty cents (\$1,189,139.80).
- ARTICLE 5. PAYMENT PROCEDURES. CONTRACTOR shall submit Applications for Payment in accordance with Article 14 of General Conditions. Applications for Payment will be processed by

ENGINEER and as provided in General Conditions and Supplemental Conditions. OWNER shall make progress payments on account of Contract Amount on the basis of CONTRACTOR'S Applications for Payment as recommended by ENGINEER and in conformance with the procedures described in General Conditions. All such payments will be measured by schedule of values established in Article 2.05 of General Conditions (and on number of units of each Unit Price item completed, if unit price contract). Upon final completion and acceptance of Work in accordance with Article 14 of General Conditions, OWNER shall pay the remainder of Contract Amount as recommended by Owner's Representative as provided in said Article 14. In accordance with Texas Water Code Section 49.276 – PAYMENT FOR CONSTRUCTION WORK, Subsection (d), in making progress payments, 5% of estimated amount shall be retained until final completion and acceptance of contract work.

ARTICLE 6. CONTRACTOR'S REPRESENTATIONS. In order to induce OWNER to enter into this Agreement CONTRACTOR makes the following representations:

- CONTRACTOR has examined and carefully studied Contract Documents (including Addenda listed in Article 7) and other related data identified in Proposal Documents.
- CONTRACTOR has visited site and become familiar with and is satisfied as to general, local, and site conditions that may affect cost, progress, performance, or furnishing of Work.
- CONTRACTOR is familiar with and is satisfied as to all federal, state, and local Legal Requirements that may affect cost, progress, performance, and furnishing of Work.
- CONTRACTOR has carefully studied all reports of explorations and tests of subsurface conditions at or contiguous to Site and all drawings of physical conditions in or relating to existing surface or subsurface structures at or contiguous to Site.
- CONTRACTOR acknowledges that such reports and drawings are not Contract Documents, are not warranted or represented in any manner by Owner to accurately show the conditions at Site, and may not be complete for CONTRACTOR'S purposes.
- CONTRACTOR acknowledges that OWNER and ENGINEER do not assume responsibility for accuracy or completeness of information and data shown or indicated in Contract Documents with respect to subsurface conditions or Underground Facilities at or contiguous to Site or CONTRACTOR'S interpretation of such information and data.
- CONTRACTOR has obtained and carefully studied (or assumes responsibility for having done so) all such additional supplementary research, examinations, investigations, explorations, tests, studies, and data concerning conditions (surface, subsurface, and Underground Facilities) at or contiguous to the Site or otherwise which may affect cost, progress, performance, or furnishing of the Work or which relate to any aspect of the means, methods, techniques, sequences, and procedures of construction to be employed by CONTRACTOR and safety precautions and programs incident thereto.
- CONTRACTOR does not consider that any additional examinations, investigations, explorations, tests, studies, or data are necessary for the performance and furnishing of Work at Contract Amount, within Contract Time Requirements and in accordance with other terms and conditions of Contract Documents.
- CONTRACTOR is aware of the general nature of work to be performed by OWNER and others at Site that relates to Work as indicated in Contract Documents.

- CONTRACTOR has correlated information known to CONTRACTOR, information and observations obtained from visits to Site, reports, and Drawings identified in Contract Documents and all additional examinations, investigations, explorations, tests, studies, and data with Contract Documents.
- CONTRACTOR has provided ENGINEER written notice of all conflicts, errors, ambiguities, or discrepancies that CONTRACTOR has discovered in Contract Documents and the written resolution thereof by ENGINEER is acceptable to CONTRACTOR, and Contract Documents are generally sufficient to indicate and convey understanding of all terms and conditions for performance and furnishing of Work.

ARTICLE 7. CONTRACT DOCUMENTS. Contract Documents are comprised of the following:

1. This Agreement.
2. Exhibits to this Agreement:
 - a. Document Title Date Page(s) - N/A
3. Performance and Payment Bonds.
4. General Conditions of Contract.
5. Supplemental Conditions, if any.
6. Project Manual, prepared by Walker Partners, dated September 2019.
7. Drawings.
8. Addenda: Addendum No. ___ through Addendum No. ____
9. CONTRACTOR'S Proposal Form pursuant to Request for Proposal.
10. Prevailing Wage Rates.
11. Following which may be delivered or issued after Effective Date of Agreement and are not attached thereto: All written Change Orders or Work Orders pursuant to Article 3.04 of General Conditions. There are no Contract Documents other than those listed in this Article. Contract Documents may only be amended, modified, or supplemented as provided in Article 3.04 of General Conditions.

ARTICLE 8. INDEMNITY PROVISIONS. GENERAL, SPECIAL, AND SUPPLEMENTAL CONDITIONS, IF ANY, INCORPORATED INTO THIS AGREEMENT CONTAIN PROVISIONS THAT MAY RELIEVE ONE PARTY FOR RESPONSIBILITY IT WOULD OTHERWISE HAVE UNDER LAW FOR DAMAGES OR OTHER LIABILITY ARISING OUT OF WORK. EACH OF THE PARTIES HERETO SPECIFICALLY AGREES THAT IT HAS A DUTY TO READ THIS AGREEMENT, GENERAL, SPECIAL, AND SUPPLEMENTAL CONDITIONS, IF ANY, AND ALL OTHER CONTRACT DOCUMENTS AND AGREES THAT IT IS CHARGED WITH NOTICE AND KNOWLEDGE OF TERMS OF THIS AGREEMENT AND ALL CONTRACT DOCUMENTS; THAT IT HAS IN FACT READ THIS AGREEMENT AND ALL CONTRACT DOCUMENTS AND IS FULLY INFORMED AND HAS FULL NOTICE AND KNOWLEDGE OF TERMS, CONDITIONS AND EFFECTS OF THIS AGREEMENT; THAT IT HAS HAD OPPORTUNITY TO BE REPRESENTED BY INDEPENDENT LEGAL COUNSEL OF ITS CHOICE PRECEDING ITS EXECUTION OF THIS AGREEMENT AND HAS RECEIVED OR VOLUNTARILY CHOSEN NOT TO RECEIVE ADVICE OF ITS ATTORNEY IN ENTERING INTO THIS AGREEMENT; AND THAT IT RECOGNIZES THAT CERTAIN TERMS OF THIS AGREEMENT AND CONTRACT DOCUMENTS RESULT IN ONE PARTY ASSUMING THE LIABILITY INHERENT IN SOME ASPECTS OF TRANSACTION AND RELIEVING OTHER PARTY OF ITS RESPONSIBILITY FOR SUCH LIABILITY. EACH

AS

PARTY HERETO AGREES AND COVENANTS THAT IT WILL NOT CONTEST VALIDITY OR ENFORCEMENT OF ANY EXCULPATORY PROVISION OF THIS AGREEMENT ON BASIS THAT THE PARTY HAD NO NOTICE OR KNOWLEDGE OF SUCH PROVISION OR THAT THE PROVISION IS NOT "CONSPICUOUS".

ARTICLE 9. MISCELLANEOUS. Terms used in this Agreement which are defined in Article 1 of General Conditions will have the meanings indicated in General Conditions. CONTRACTOR certifies that it has not engaged in corrupt, fraudulent, collusive, or coercive practices in competing for or in executing Contract. For purposes of this Article 9:

1. "corrupt practice" means the offering, giving, receiving, or soliciting of anything of value likely to influence the action of a public official in proposal process or in Contract execution;
2. "fraudulent practice" means an intentional misrepresentation of facts made
 - (a) to influence proposal process or execution of Contract to detriment of OWNER,
 - (b) to establish Proposal or Contract prices at artificial noncompetitive levels, or
 - (c) to deprive OWNER of benefits of free and open competition;
3. "collusive practice" means a scheme or arrangement between two or more Proposers, with or without knowledge of OWNER, a purpose of which is to establish Proposal prices at artificial, non-competitive levels; and
4. "coercive practice" means harming or threatening to harm, directly or indirectly, persons or their property to influence their participation in the proposal process or affect execution of Contract.

No assignment by a party hereto of any rights or interests in Contract will be binding on another party hereto without written consent of party sought to be bound; and, specifically but without limitation, moneys that may become due and moneys that are due may not be assigned without such consent (except to the extent that effect of this restriction may be limited by law), and unless specifically stated to contrary in any written consent to an assignment no assignment will release or discharge assignor from any duty or responsibility under Contract.

OWNER and CONTRACTOR each binds itself, its officers, directors, shareholders, partners, members, successors, assigns, and legal representatives to other party hereto, its officers, directors, shareholders, partners, members, successors, assigns and legal representatives in respect to all covenants, agreements, and obligations contained in Contract Documents. Any provision or part thereof of Contract Documents held to be void or unenforceable under any Law or Regulation shall be deemed stricken, and all remaining provisions or parts thereof shall continue to be valid and binding upon OWNER and CONTRACTOR, who agree that Contract Documents shall be reformed to replace such stricken provision or part thereof with a valid and enforceable provision that comes as close as possible to expressing intention of the stricken provision or part thereof.

IN WITNESS WHEREOF, OWNER, and CONTRACTOR have signed this Agreement in duplicate. One counterpart has been delivered to OWNER, one counterpart has been delivered to CONTRACTOR and one counterpart has been delivered to ENGINEER. All portions of Contract Documents have been signed, initialed, or otherwise clearly identified by OWNER and CONTRACTOR or identified by ENGINEER on their behalf.

This Agreement will be effective on the 23rd day of December (which is effective date of Agreement).

OWNER: City of Bastrop

By: [Signature]
Attest: [Signature]

Address for giving notices:
1311 Chestnut St.
Bastrop, Texas 78102

CONTRACTOR: Angel Brothers Enterprises, Ltd.

By: [Signature]
Attest: [Signature]

(CORPORATE SEAL)

Address for giving notices:
23990 State Highway 6
Nevasota, TX 77868

END OF SECTION

[Handwritten mark]

1977

Light of the
... ..

... ..

...

...

...

Bond Number: 58S213088

SECTION 00 61 14

PERFORMANCE BOND

STATE OF TEXAS

COUNTY OF Bastrop

KNOW ALL MEN BY THESE PRESENTS: That Angel Brothers Enterprises, Ltd. (Contractor) of City of Baytown, County of Harris, and State of Texas, as Principal, and Liberty Mutual Fire Insurance Company authorized under Laws of State of Texas to act as surety on bonds for principals, are held and firmly bound unto City of Bastrop (Owner), in the penal sum of One Million, One Hundred Eighty-Nine Thousand, One Hundred Thirty-Nine and 80/100 Dollars (\$1,189,139.80) for the payment whereof, said Principal and Surety bind themselves, and their heirs, administrators, executors, successors and assigns, jointly and severally, by these presents:

WHEREAS, Principal has entered into a certain written contract with Owner, dated ____ day of _____, 20____, for construction of RFP No. 20-001 City of Bastrop - Streets, Pavement, and Preventative Maintenance in accordance with Drawings, Specifications, and terms and conditions related thereto to which Contract is hereby referred to and make a part hereof as fully and to same extent as if copied at length herein.

NOW, THEREFORE, THE CONDITION OF THIS OBLIGATION IS SUCH, that if said Principal shall faithfully perform said Contract and shall in all respects duly and faithfully observe and perform all and singular the covenants, conditions and agreements in and by said contract agreed and covenanted by Principal to be observed and performed, and according to the true intent and meaning of said Contract and Drawings and Specifications hereto annexed, then this obligation shall be void; otherwise to remain in full force and effect;

PROVIDED, HOWEVER, that this bond is executed pursuant to provisions of Chapter 2253 of Texas Government Code as amended and all liabilities on this bond shall be determined in accordance with the provisions of said Statute to same extent as if it were copied at length herein. Surety, for value received, stipulates and agrees that no change, extension of time, alteration or addition to the terms of contract, or to work performed thereunder, or drawings, Specifications, or Drawings, accompanying same, shall in anyway affect its obligation on this bond, and it does hereby waive notice of any such change, extension of time, alteration or addition to terms of contract, or work to be performed thereunder.

IN WITNESS WHEREOF, the said Principal and Surety have signed and sealed this instrument on _____ day of _____, 20__.

Contractor: Angel Brothers Enterprises, Ltd. Surety: Liberty Mutual Fire Insurance Company
By: [Signature] By: [Signature]
Name: Kyle Lewis Name: Lauren O. Moudy
Title: Vice President Title: Attorney in Fact
Date: 12/16/19

ATTEST/SURETY WITNESS: [Signature]
Alyson Carmichael, Witness
Full Name of Surety: Liberty Mutual Fire Insurance Company

(SEAL)

Address of Surety for Notice
2200 Renaissance Blvd., Suite 400
King of Prussia, PA 19406-2755

Telephone Number of Surety: 1-877-751-2640
By: [Signature] By: [Signature]
Name: Alyson Carmichael Name: Lauren O. Moudy
Title: Witness Title: Attorney-in-Fact
Date: _____ Date: _____

END OF SECTION

26

Bond Number: 58S213088

SECTION 00 61 13

PAYMENT BOND

STATE OF TEXAS

COUNTY OF Bastrop

KNOW ALL MEN BY THESE PRESENTS: That Angel Brothers Enterprises, Ltd. (Contractor) of City of Baytown, County of Harris, and State of Texas, as Principal, and Liberty Mutual Fire Insurance Company authorized under the Laws of the State of Texas to act as surety on bonds for principals, are held and firmly bound unto City of Bastrop (Owner), in the penal sum of One Million, One Hundred Eighty-Nine Thousand, One Hundred Thirty-Nine and 80/100 Dollars (\$ 1,189,139.80) for payment whereof, the said Principal and Surety bind themselves, and their heirs, administrators, executors, successors and assigns, jointly and severally, by these presents:

WHEREAS, Principal has entered into a certain written contract with Owner, dated the ____ day of _____, 20__, for construction of RFP No. 20-001 City of Bastrop - Streets, Pavement, and Preventative Maintenance in accordance with Drawings, Specifications, and terms and conditions related thereto to which Contract is hereby referred to and make a part hereof as fully and to the same extent as if copied at length herein.

NOW, THEREFORE, THE CONDITIONS OF THIS OBLIGATION IS SUCH, that if said Principal shall pay all claimants supplying labor and material to him or a Sub-Contractor in prosecution of work provided for in said contract, then, this obligation shall be void; otherwise to remain in full force and effect;

PROVIDED, HOWEVER, that this bond is executed pursuant to the provisions of Chapter 2253 of Texas Government Code as amended and all liabilities on this bond shall be determined in accordance with the provisions of said Statute to the same extent as if it were copied at length herein. Surety, for value received, stipulates and agrees that no change, extension of time, alteration or addition to the terms of contract, or to work performed thereunder, or Specifications, or Drawings, accompanying the same, shall in anyway affect its obligation on this bond, and it does hereby waive notice of any such change, extension of time, alteration or addition to terms of contract, or work to be performed thereunder.

IN WITNESS WHEREOF, the said Principal and Surety have signed and sealed this instrument on the _____ day
of _____, 20__.

Contractor: Angel Brothers Enterprises, Ltd. Surety: Liberty Mutual Fire Insurance Company
By: [Signature] By: [Signature]
Name: Kyle Lewis Name: Lauren O. Moudy
Title: Vice President Title: Attorney in Fact
Date: 12/16/19

ATTEST/SURETY WITNESS: [Signature]
Alyson Carmichael, Witness
Full Name of Surety: Liberty Mutual Fire Insurance Company

(SEAL)

Address of Surety for Notice
2200 Renaissance Blvd., Suite 400
King of Prussia, PA 19406-2755

Telephone Number of Surety: 1-877-751-2640
By: [Signature] By: [Signature]
Name: Alyson Carmichael Name: Lauren O. Moudy
Title: Witness Title: Attorney-in-Fact
Date: _____ Date: _____

END OF SECTION

[Handwritten mark]



This Power of Attorney limits the acts of those named herein, and they have no authority to bind the Company except in the manner and to the extent herein stated.

Liberty Mutual Fire Insurance Company
Wausau, Wisconsin
POWER OF ATTORNEY

Certificate No: 8202693 - 971801

KNOWN ALL PERSONS BY THESE PRESENTS: Liberty Mutual Fire Insurance Company, being a Wisconsin Corporation having its principal office in the City of Wausau, State of Wisconsin does hereby make, constitute and appoint Ashley Britt, Alyson Carmichael, Robert C. Davis, Tabitha Dorman, Nikole Jeannette, Lacey Mayfield, Barry K. McCord, David T. Miclette, Lauren O. Moudy, Heather Noles, Robert M. Overbey, Jr.

all of the city of Houston state of TX each individually if there be more than one named, its true and lawful attorney(s)-in-fact, with full power and authority hereby conferred in their/its name, place and stead, to sign, execute, acknowledge and deliver in their/its behalf, and as their/its act and deed, without power of redelegation, as follows:

bonds, undertakings, recognizances, contracts of indemnity, and all other surety obligations, as required, unlimited as to Dollar amount

and to bind the Company(ies) making this appointment thereby as fully and to the same extent as if such bond or undertaking was signed by the duly authorized officers of the Company(ies), and all the acts of said attorney(s), pursuant to the authority herein given, are hereby ratified and confirmed.

AUTHORITY FOR MAKING APPOINTMENT OF ATTORNEYS-IN-FACT

Appointment of Attorneys-in-Fact by Liberty Mutual Fire Insurance Company are made pursuant to Article V, Section 10 of Liberty Mutual Fire Insurance Company's By-Laws, as amended and by Unanimous Consent of the Board of Directors dated May 21st, 2013. Further, the President of Liberty Mutual Fire Insurance Company, executed a Delegation of Authority and authorized the assistant secretary signing below to appoint attorneys-in-fact as may be necessary to act on behalf of Liberty Mutual Fire Insurance Company to make execute, seal, acknowledge and deliver as surety any and all undertakings, bonds, recognizances, and other surety obligations.

IN WITNESS WHEREOF, Liberty Mutual Fire Insurance Company has caused these presents to be signed by its authorized representatives, and its Corporate Seal to be hereto affixed, this 5th day of December, 2019.



Liberty Mutual Fire Insurance Company
By: David M. Carey
David M. Carey, Assistant Secretary

Attest: Lisa Love
Lisa Love

State of PENNSYLVANIA
County of MONTGOMERY ss

The foregoing instrument was acknowledged before me this 5th day of December, 2019 by David M. Carey, an authorized representative of Liberty Mutual Fire Insurance Company.



COMMONWEALTH OF PENNSYLVANIA
Notarial Seal
Teresa Pastella, Notary Public
Upper Merion Twp., Montgomery County
My Commission Expires March 28, 2021
Member, Pennsylvania Association of Notaries

By: Teresa Pastella
Teresa Pastella, Notary Public

Not valid for mortgage, note, loan, letter of credit, currency rate, interest rate or residual value guarantees.

To confirm the validity of this Power of Attorney call 1-610-832-8240 between 9:00 am and 4:30 pm EST on any business day.

CERTIFICATE

I, the undersigned, an Assistant Secretary of Liberty Mutual Fire Insurance Company, do hereby certify that the original power of attorney of which the foregoing is a full, true and correct copy, is in full force and effect on the date of this certificate; and I do further certify that the officer or official who executed the said power of attorney was one of the officers or officials specially authorized by the Board of Directors to appoint attorneys-in-fact as provided in the Unanimous Consent and Vote of the Board of Directors of Liberty Mutual Fire Insurance Company dated May 21, 2013.

This certificate and the above power of attorney may be signed by facsimile or mechanically reproduced signatures under and by authority of the Board of Directors of Liberty Mutual Fire Insurance Company evidenced by the Unanimous Consent and Vote of the Board of Directors dated June 28, 2006 wherein it was

VOTED that the signatures of such officers and the seal of the Company may be affixed to any such power of attorney or to any certificate relating thereto by facsimile, and any such power of attorney or certificate bearing such facsimile signature and facsimile seal shall be valid and binding upon the Company when so affixed and in the future with respect to any surety undertakings, bonds, recognizances and other surety obligations to which it is attached.

IN TESTIMONY WHEREOF, I have hereunto subscribed my name and affixed the corporate seal of the said company, affixed, this _____ day of _____.



By: Renee C. Llewellyn
Renee C. Llewellyn, Assistant Secretary

John



TEXAS
IMPORTANT NOTICE

To obtain information or make a complaint:

You may call toll-free for information or to make a complaint at
1-877-751-2640

You may also write to:

2200 Renaissance Blvd., Ste. 400
King of Prussia, PA 19406-2755

You may contact the Texas Department of Insurance to obtain information on companies, coverages, rights or complaints at
1-800-252-3439

You may write the Texas Department of Insurance Consumer Protection (111-1A)
P. O. Box 149091
Austin, TX 78714-9091
FAX: (512) 490-1007
Web: <http://www.tdi.texas.gov>
E-mail: ConsumerProtection@tdi.texas.gov

PREMIUM OR CLAIM DISPUTES:

Should you have a dispute concerning your premium or about a claim you should first contact the agent or call 1-800-843-6446. If the dispute is not resolved, you may contact the Texas Department of Insurance.

ATTACH THIS NOTICE TO YOUR POLICY:

This notice is for information only and does not become a part or condition of the attached document.

TEXAS
AVISO IMPORTANTE

Para obtener informacion o para someter una queja:

Usted puede llamar al numero de telefono gratis para informacion o para someter una queja al
1-877-751-2640

Usted tambien puede escribir a:

2200 Renaissance Blvd., Ste. 400
King of Prussia, PA 19406-2755

Puede comunicarse con el Departamento de Seguros de Texas para obtener informacion acerca de companias, coberturas, derechos o quejas al
1-800-252-3439

Puede escribir al Departamento de Seguros de Texas Consumer Protection (111-1A)
P. O. Box 149091
Austin, TX 78714-9091
FAX # (512) 490-1007
Web: <http://www.tdi.texas.gov>
E-mail: ConsumerProtection@tdi.texas.gov

DISPUTAS SOBRE PRIMAS O RECLAMOS:

Si tiene una disputa concerniente a su prima o a un reclamo, debe comunicarse con el agente o primero. Si no se resuelve la disputa, puede entonces comunicarse con el departamento (TDI)

UNA ESTE AVISO A SU POLIZA:

Este aviso es solo para proposito de informacion y no se convierte en parte o condicion del documento adjunto.

al



CERTIFICATE OF LIABILITY INSURANCE

DATE (MM/DD/YYYY)

12/12/2019

THIS CERTIFICATE IS ISSUED AS A MATTER OF INFORMATION ONLY AND CONFERS NO RIGHTS UPON THE CERTIFICATE HOLDER. THIS CERTIFICATE DOES NOT AFFIRMATIVELY OR NEGATIVELY AMEND, EXTEND OR ALTER THE COVERAGE AFFORDED BY THE POLICIES BELOW. THIS CERTIFICATE OF INSURANCE DOES NOT CONSTITUTE A CONTRACT BETWEEN THE ISSUING INSURER(S), AUTHORIZED REPRESENTATIVE OR PRODUCER, AND THE CERTIFICATE HOLDER.

IMPORTANT: If the certificate holder is an ADDITIONAL INSURED, the policy(ies) must be endorsed. If SUBROGATION IS WAIVED, subject to the terms and conditions of the policy, certain policies may require an endorsement. A statement on this certificate does not confer rights to the certificate holder in lieu of such endorsement(s).

PRODUCER Bowen, Miclette & Britt Insurance Agency, LLC 1111 North Loop West, #400 Houston TX 77008	CONTACT NAME: Linh Hoang	
	PHONE (A/C, Ho, Ext): 713-880-7100 FAX (A/C, No): 713-880-7166 E-MAIL ADDRESS: lhoang@bmbinc.com	
INSURED Angel Brothers Holdings Corp Angel Brothers Enterprises, Ltd. Angel Brothers Properties, LLC 3003 Kilgore Parkway Baytown TX 77523	INSURER(S) AFFORDING COVERAGE	NAIC #
	INSURER A: Travelers Property Casualty Co of Amer	25674
	INSURER B: AXIS Surplus Insurance Company	26620
	INSURER C: RSUI Indemnity	22314
	INSURER D: Travelers Indemnity Company	25658
	INSURER E: INSURER F:	

COVERAGES CERTIFICATE NUMBER: 983282499 REVISION NUMBER:

THIS IS TO CERTIFY THAT THE POLICIES OF INSURANCE LISTED BELOW HAVE BEEN ISSUED TO THE INSURED NAMED ABOVE FOR THE POLICY PERIOD INDICATED. NOTWITHSTANDING ANY REQUIREMENT, TERM OR CONDITION OF ANY CONTRACT OR OTHER DOCUMENT WITH RESPECT TO WHICH THIS CERTIFICATE MAY BE ISSUED OR MAY PERTAIN, THE INSURANCE AFFORDED BY THE POLICIES DESCRIBED HEREIN IS SUBJECT TO ALL THE TERMS, EXCLUSIONS AND CONDITIONS OF SUCH POLICIES. LIMITS SHOWN MAY HAVE BEEN REDUCED BY PAID CLAIMS.

INSR LTR	TYPE OF INSURANCE	ADDL SUBR INSD WVD	POLICY NUMBER	POLICY EFF (MM/DD/YYYY)	POLICY EXP (MM/DD/YYYY)	LIMITS
A	<input checked="" type="checkbox"/> COMMERCIAL GENERAL LIABILITY <input type="checkbox"/> CLAIMS-MADE <input checked="" type="checkbox"/> OCCUR GEN'L AGGREGATE LIMIT APPLIES PER: <input type="checkbox"/> POLICY <input checked="" type="checkbox"/> PRO-JECT <input checked="" type="checkbox"/> LOC OTHER:	Y Y	VTC2JCO5468B922TIL19	10/1/2019	10/1/2020	EACH OCCURRENCE \$ 1,000,000 DAMAGE TO RENTED PREMISES (Ea occurrence) \$ 300,000 MED EXP (Any one person) \$ 10,000 PERSONAL & ADV INJURY \$ 1,000,000 GENERAL AGGREGATE \$ 2,000,000 PRODUCTS - COM/OP AGG \$ 2,000,000 \$
A	<input checked="" type="checkbox"/> AUTOMOBILE LIABILITY <input type="checkbox"/> ANY AUTO <input type="checkbox"/> ALL OWNED AUTOS <input type="checkbox"/> HIRED AUTOS <input type="checkbox"/> SCHEDULED AUTOS <input type="checkbox"/> NON-OWNED AUTOS	Y Y	VTC2JCAP5468B934TIL19	10/1/2019	10/1/2020	COMBINED SINGLE LIMIT (Ea accident) \$ 2,000,000 BODILY INJURY (Per person) \$ BODILY INJURY (Per accident) \$ PROPERTY DAMAGE (Per accident) \$ \$
B	<input type="checkbox"/> UMBRELLA LIAB <input checked="" type="checkbox"/> OCCUR <input checked="" type="checkbox"/> EXCESS LIAB <input type="checkbox"/> CLAIMS-MADE DED RETENTION \$	Y Y	P00100003993302	10/1/2019	10/1/2020	EACH OCCURRENCE \$ 4,000,000 AGGREGATE \$ 4,000,000 \$
D	WORKERS COMPENSATION AND EMPLOYERS' LIABILITY ANY PROPRIETOR/PARTNER/EXECUTIVE OFFICER/MEMBER EXCLUDED? (Mandatory in NH) If yes, describe under DESCRIPTION OF OPERATIONS below	Y/N N N/A	UB9K1590411925K	10/1/2019	10/1/2020	<input checked="" type="checkbox"/> PER STATUTE <input type="checkbox"/> OTH-ER E.L. EACH ACCIDENT \$ 1,000,000 E.L. DISEASE - EA EMPLOYEE \$ 1,000,000 E.L. DISEASE - POLICY LIMIT \$ 1,000,000
C	Excess Liability	Y Y	NHA087632	10/1/2019	10/1/2020	Each Occurrence 6,000,000 Aggregate 6,000,000

DESCRIPTION OF OPERATIONS / LOCATIONS / VEHICLES (ACORD 101, Additional Remarks Schedule, may be attached if more space is required)
 The following policy provisions and/or endorsements form part of the policies of insurance represented by this certificate of insurance. The terms contained in the policies and/or endorsements supersede the representations made herein. Electronic copies of the policy provisions and/or endorsements listed below are available by emailing: certificates@bmbinc.com

General Liability:
 Blanket additional insured Ongoing Operations per form # CGD604 08/13
 Blanket additional insured Completed Operations per form #CGD604 08/13
 Blanket waiver of subrogation per form #CGD316 11/11
 See Attached...

CERTIFICATE HOLDER	CANCELLATION
City of Bastrop 1311 Chestnut Street Bastrop TX 78602	SHOULD ANY OF THE ABOVE DESCRIBED POLICIES BE CANCELLED BEFORE THE EXPIRATION DATE THEREOF, NOTICE WILL BE DELIVERED IN ACCORDANCE WITH THE POLICY PROVISIONS. AUTHORIZED REPRESENTATIVE 

© 1988-2014 ACORD CORPORATION. All rights reserved.





ADDITIONAL REMARKS SCHEDULE

AGENCY Bowen, Miclette & Britt		NAMED INSURED Angel Brothers Holdings Corp Angel Brothers Enterprises, Ltd. Angel Brothers Properties, LLC 3003 Kilgore Parkway Baytown TX 77523	
POLICY NUMBER		EFFECTIVE DATE:	
CARRIER	NAIC CODE		

ADDITIONAL REMARKS

THIS ADDITIONAL REMARKS FORM IS A SCHEDULE TO ACORD FORM,
 FORM NUMBER: 25 FORM TITLE: CERTIFICATE OF LIABILITY INSURANCE

Blanket primary/non-contributory per form # CGD604 08/13

Automobile:
 Blanket additional insured per form # CAT474 02/16
 Blanket waiver of subrogation per form # CAT353 02/15
 Blanket primary/non-contributory per form # CAT474 02/16

Worker's Compensation:
 Blanket Texas waiver of subrogation per form #WC420304B
 Blanket Alternate Employer per form WC00030100

Excess (first layer):
 Blanket additional insured per form # AXIS1010402 04/17
 Blanket waiver of subrogation per form # AXIS1010425 04/17
 Blanket Primary Non Contributory per form # AXIS1010461 04/17

Excess Liability (second layer)
 Blanket additional insured per form # RSG31001 05/07
 Blanket waiver of subrogation per form # RSG94083 03/06

Re: Project: Streets, Pavement, and Preventative Maintenance, Project No. 4-01126
 Contract Amount: \$1,189,139.80

Certificate Holder Includes: Walker Partners

Job

THIS ENDORSEMENT CHANGES THE POLICY. PLEASE READ IT CAREFULLY.

BLANKET ADDITIONAL INSURED – AUTOMATIC STATUS IF REQUIRED BY WRITTEN CONTRACT (CONTRACTORS)

This endorsement modifies insurance provided under the following:
COMMERCIAL GENERAL LIABILITY COVERAGE PART

1. The following is added to **SECTION II – WHO IS AN INSURED**:

Any person or organization that:

- a. You agree in a "written contract requiring insurance" to include as an additional insured on this Coverage Part; and
- b. Has not been added as an additional insured for the same project by attachment of an endorsement under this Coverage Part which includes such person or organization in the endorsement's schedule;

is an insured, but:

- a. Only with respect to liability for "bodily injury", "property damage" or "personal injury"; and
- b. Only as described in Paragraph (1), (2) or (3) below, whichever applies:

(1) If the "written contract requiring insurance" specifically requires you to provide additional insured coverage to that person or organization by the use of:

- (a) The Additional Insured – Owners, Lessees or Contractors – (Form B) endorsement CG 20 10 11 85; or
- (b) Either or both of the following: the Additional Insured – Owners, Lessees or Contractors – Scheduled Person Or Organization endorsement CG 20 10 10 01, or the Additional Insured – Owners, Lessees or Contractors – Completed Operations endorsement CG 20 37 10 01;

the person or organization is an additional insured only if the injury or damage arises out of "your work" to which the "written contract requiring insurance" applies;

- (2) If the "written contract requiring insurance" specifically requires you to provide additional insured coverage to that person or organization by the use of:

(a) The Additional Insured – Owners, Lessees or Contractors – Scheduled Person or Organization endorsement CG 20 10 07 04 or CG 20 10 04 13, the Additional Insured – Owners, Lessees or Contractors – Completed Operations endorsement CG 20 37 07 04 or CG 20 37 04 13, or both of such endorsements with either of those edition dates; or

(b) Either or both of the following: the Additional Insured – Owners, Lessees or Contractors – Scheduled Person Or Organization endorsement CG 20 10, or the Additional Insured – Owners, Lessees or Contractors – Completed Operations endorsement CG 20 37, without an edition date of such endorsement specified;

the person or organization is an additional insured only if the injury or damage is caused, in whole or in part, by acts or omissions of you or your subcontractor in the performance of "your work" to which the "written contract requiring insurance" applies; or

(3) If neither Paragraph (1) nor (2) above applies:

(a) The person or organization is an additional insured only if, and to the extent that, the injury or damage is caused by acts or omissions of you or your subcontractor in the performance of "your work" to which the "written contract requiring insurance" applies; and

(b) The person or organization does not qualify as an additional insured with respect to the independent acts or omissions of such person or organization.

2. The insurance provided to the additional insured by this endorsement is limited as follows:
- a. If the Limits of Insurance of this Coverage Part shown in the Declarations exceed the minimum limits of liability required by the "written contract requiring insurance", the insurance provided to the additional insured will be limited to such minimum required limits of liability. For the purposes of determining whether this limitation applies, the minimum limits of liability required by the "written contract requiring insurance" will be considered to include the minimum limits of liability of any Umbrella or Excess liability coverage required for the additional insured by that "written contract requiring insurance". This endorsement will not increase the limits of insurance described in Section III – Limits Of Insurance.
 - b. The insurance provided to the additional insured does not apply to "bodily injury", "property damage" or "personal injury" arising out of the rendering of, or failure to render, any professional architectural, engineering or surveying services, including:
 - (1) The preparing, approving, or failing to prepare or approve, maps, shop drawings, opinions, reports, surveys, field orders or change orders, or the preparing, approving, or failing to prepare or approve, drawings and specifications; and
 - (2) Supervisory, inspection, architectural or engineering activities.
 - c. The insurance provided to the additional insured does not apply to "bodily injury" or "property damage" caused by "your work" and included in the "products-completed operations hazard" unless the "written contract requiring insurance" specifically requires you to provide such coverage for that additional insured during the policy period.
3. The insurance provided to the additional insured by this endorsement is excess over any valid and collectible other insurance, whether primary, excess, contingent or on any other basis, that is available to the additional insured. However, if the "written contract requiring insurance" specifically requires that this insurance apply on a primary basis or a primary and non-contributory basis, this insurance is primary to other insurance available to the additional insured under which that person or organization qualifies as a named insured, and we will not share with that other insurance. But the insurance provided to the additional insured by this endorsement still is excess over any valid and collectible other insurance, whether primary, excess, contingent or on any other basis, that is available to the additional insured when that person or organization is an additional insured, or is any other insured that does not qualify as a named insured, under such other insurance.
4. As a condition of coverage provided to the additional insured by this endorsement:
- a. The additional insured must give us written notice as soon as practicable of an "occurrence" or an offense which may result in a claim. To the extent possible, such notice should include:
 - (1) How, when and where the "occurrence" or offense took place;
 - (2) The names and addresses of any injured persons and witnesses; and
 - (3) The nature and location of any injury or damage arising out of the "occurrence" or offense.
 - b. If a claim is made or "suit" is brought against the additional insured, the additional insured must:
 - (1) Immediately record the specifics of the claim or "suit" and the date received; and
 - (2) Notify us as soon as practicable.

The additional insured must see to it that we receive written notice of the claim or "suit" as soon as practicable.
 - c. The additional insured must immediately send us copies of all legal papers received in connection with the claim or "suit", cooperate with us in the investigation or settlement of the claim or defense against the "suit", and otherwise comply with all policy conditions.
 - d. The additional insured must tender the defense and indemnity of any claim or "suit" to any provider of other insurance which would cover the additional insured for a loss we cover under this endorsement. However, this condition does not affect whether the insurance provided to the additional insured by this endorsement is primary to other insurance available to the additional insured which covers that person or organization as a named insured as described in Paragraph 3. above.
5. The following is added to the **DEFINITIONS** Section:
- "Written contract requiring insurance" means that part of any written contract or agreement under which you are required to include a person or or-

Policy Number: VTC2JCO5468B92219
Effective Date: 10/01/2019 - 10/01/2020

COMMERCIAL GENERAL LIABILITY

ganization as an additional insured on this Coverage Part, provided that the "bodily injury" and "property damage" occurs, and the "personal injury" is caused by an offense committed, during the policy period and:

- a. After the signing and execution of the contract or agreement by you; and
- b. While that part of the contract or agreement is in effect.



TABLE OF CONTENTS

	<u>Page</u>
ARTICLE 1 - DEFINITIONS AND TERMINOLOGY	4
1.01 <i>Defined Terms</i>	6
1.02 <i>Terminology</i>	8
ARTICLE 2 - PRELIMINARY MATTERS	7
2.01 <i>Delivery of Bonds and Evidence of Insurance</i>	7
2.02 <i>Copies of Documents</i>	7
2.03 <i>Commencement of Contract Times; Notice to Proceed</i>	7
2.04 <i>Starting the Work</i>	7
2.05 <i>Before Starting Construction</i>	7
2.06 <i>Preconstruction Conference</i>	7
2.07 <i>Initial Acceptance of Schedules</i>	7
ARTICLE 3 - CONTRACT DOCUMENTS: INTENT, AMENDING, REUSE	8
3.01 <i>Intent</i>	8
3.02 <i>Reference Standards</i>	8
3.03 <i>Reporting and Resolving Discrepancies</i>	8
3.04 <i>Amending and Supplementing Contract Documents</i>	9
3.05 <i>Reuse of Documents</i>	9
3.06 <i>Electronic Data</i>	9
ARTICLE 4 - AVAILABILITY OF LANDS; SUBSURFACE AND PHYSICAL CONDITIONS; HAZARDOUS ENVIRONMENTAL CONDITIONS; REFERENCE POINTS	9
4.01 <i>Availability of Lands</i>	9
4.02 <i>Subsurface and Physical Conditions</i>	10
4.03 <i>Differing Subsurface or Physical Conditions</i>	10
4.04 <i>Underground Facilities</i>	11
4.05 <i>Reference Points</i>	11
4.06 <i>Hazardous Environmental Condition at Site</i>	11
ARTICLE 5 - BONDS AND INSURANCE	12
5.01 <i>Performance, Payment, and Other Bonds</i>	12
5.02 <i>Licensed Sureties and Insurers</i>	13
5.03 <i>Certificates of Insurance</i>	13
5.04 <i>Contractor's Liability Insurance</i>	13
5.05 <i>Owner's Liability Insurance</i>	14
5.06 <i>Property Insurance</i>	14
5.07 <i>Waiver of Rights</i>	15
5.08 <i>Receipt and Application of Insurance Proceeds</i>	15
5.09 <i>Acceptance of Bonds and Insurance; Option to Replace</i>	15
5.10 <i>Partial Utilization, Acknowledgment of Property Insurer</i>	16
ARTICLE 6 - CONTRACTOR'S RESPONSIBILITIES	16
6.01 <i>Supervision and Superintendence</i>	16
6.02 <i>Labor; Working Hours</i>	16
6.03 <i>Services, Materials, and Equipment</i>	16
6.04 <i>Progress Schedule</i>	16
6.05 <i>Substitutes and "Or-Equals"</i>	17
6.06 <i>Concerning Subcontractors, Suppliers, and Others</i>	18
6.07 <i>Patent Fees and Royalties</i>	19
6.08 <i>Permits</i>	19
6.09 <i>Laws and Regulations</i>	19
6.10 <i>Taxes</i>	20
6.11 <i>Use of Site and Other Areas</i>	20
6.12 <i>Record Documents</i>	20
6.13 <i>Safety and Protection</i>	20
6.14 <i>Safety Representative</i>	21
6.15 <i>Hazard Communication Programs</i>	21
6.16 <i>Emergencies</i>	21
6.17 <i>Shop Drawings and Samples</i>	21
6.18 <i>Continuing the Work</i>	22

21

6.19	Contractor's General Warranty and Guarantee.....	22
6.20	Indemnification	22
6.21	Delegation of Professional Design Services	23
ARTICLE 7 - OTHER WORK AT THE SITE		23
7.01	Related Work at Site.....	23
7.02	Coordination.....	24
7.03	Legal Relationships.....	24
ARTICLE 8 - OWNER'S RESPONSIBILITIES		24
8.01	Communications to Contractor.....	24
8.02	Replacement of Engineer	24
8.03	Furnish Data.....	24
8.04	Pay When Due	24
8.05	Lands and Easements; Reports and Tests	24
8.06	Insurance	24
8.07	Change Orders.....	24
8.08	Inspections, Tests, and Approvals	24
8.09	Limitations on Owner's Responsibilities	25
8.10	Undisclosed Hazardous Environmental Condition.....	25
8.11	Evidence of Financial Arrangements.....	25
ARTICLE 9 - ENGINEER'S STATUS DURING CONSTRUCTION.....		25
9.01	Owner's Representative	25
9.02	Visits to Site	25
9.03	Project Representative.....	25
9.04	Authorized Variations in Work	25
9.05	Rejecting Defective Work.....	25
9.06	Shop Drawings, Change Orders and Payments.....	26
9.07	Determinations for Unit Price Work.....	26
9.08	Decisions on Requirements of Contract Documents and Acceptability of Work	26
9.09	Limitations on Engineer's Authority and Responsibilities	26
ARTICLE 10 - CHANGES IN THE WORK; CLAIMS		26
10.01	Authorized Changes in the Work	26
10.02	Unauthorized Changes in the Work.....	27
10.03	Execution of Change Orders.....	27
10.04	Notification to Surety.....	27
10.05	Claims	27
ARTICLE 11 - COST OF THE WORK; ALLOWANCES; UNIT PRICE WORK.....		28
11.01	Cost of the Work	28
11.02	Allowances.....	29
11.03	Unit Price Work.....	29
ARTICLE 12 - CHANGE OF CONTRACT PRICE; CHANGE OF CONTRACT TIMES.....		30
12.01	Change of Contract Price	30
12.02	Change of Contract Times	30
12.03	Delays	31
ARTICLE 13 - TESTS AND INSPECTIONS; CORRECTION, REMOVAL OR ACCEPTANCE OF DEFECTIVE WORK.....		31
13.01	Notice of Defects.....	31
13.02	Access to Work.....	31
13.03	Tests and Inspections	31
13.04	Uncovering Work.....	32
13.05	Owner May Stop the Work.....	32
13.06	Correction or Removal of Defective Work.....	32
13.07	Correction Period.....	32
13.08	Acceptance of Defective Work	33
13.09	Owner May Correct Defective Work.....	33
ARTICLE 14 - PAYMENTS TO CONTRACTOR AND COMPLETION		33
14.01	Schedule of Values	33
14.02	Progress Payments	34
14.03	Contractor's Warranty of Title	35
14.04	Substantial Completion.....	35
14.05	Partial Utilization.....	36
14.06	Final Inspection	36
14.07	Final Payment.....	36

AK

14.08 *Final Completion Delayed*.....37
14.09 *Waiver of Claims*37
ARTICLE 15 - SUSPENSION OF WORK AND TERMINATION.....37
15.01 *Owner May Suspend Work*.....37
15.02 *Owner May Terminate for Cause*.....37
15.03 *Owner May Terminate For Convenience*.....38
15.04 *Contractor May Stop Work or Terminate*38
ARTICLE 16 - DISPUTE RESOLUTION.....38
16.01 *Methods and Procedures*38
ARTICLE 17 - MISCELLANEOUS.....39
17.01 *Giving Notice*39
17.02 *Computation of Times*.....39
17.03 *Cumulative Remedies*.....39
17.04 *Survival of Obligations*39
17.05 *Controlling Law*.....39
17.06 *Headings*.....39

GENERAL CONDITIONS

ARTICLE 1 - DEFINITIONS AND TERMINOLOGY

1.01 *Defined Terms*

A. Wherever used in the Bidding Requirements or Contract Documents and printed with initial capital letters, the terms listed below will have the meanings indicated which are applicable to both the singular and plural thereof. In addition to terms specifically defined, terms with initial capital letters in the Contract Documents include references to identified articles and paragraphs, and the titles of other documents or forms.

1. *Addenda*--Written or graphic instruments issued prior to the opening of Bids which clarify, correct, or change the Bidding Requirements or the proposed Contract Documents.

2. *Agreement*--The written instrument which is evidence of the agreement between Owner and Contractor covering the Work.

3. *Application for Payment*--The form acceptable to Engineer which is to be used by Contractor during the course of the Work in requesting progress or final payments and which is to be accompanied by such supporting documentation as is required by the Contract Documents.

4. *Asbestos*--Any material that contains more than one percent asbestos and is friable or is releasing asbestos fibers into the air above current action levels established by the United States Occupational Safety and Health Administration.

5. *Bid*--The offer or proposal of a Bidder submitted on the prescribed form setting forth the prices for the Work to be performed.

6. *Bidder*--The individual or entity who submits a Bid directly to Owner.

7. *Bidding Documents*--The Bidding Requirements and the proposed Contract Documents (including all Addenda).

8. *Bidding Requirements*--The Advertisement or Invitation to Bid, Instructions to Bidders, bid security of acceptable form, if any, and the Bid Form with any supplements.

9. *Change Order*--A document recommended by Engineer which is signed by Contractor and Owner and authorizes an addition, deletion, or revision in the Work or an adjustment in the Contract Price or the Contract Times, issued on or after the Effective Date of the Agreement.

10. *Claim*--A demand or assertion by Owner or Contractor seeking an adjustment of Contract Price or Contract Times, or both, or other relief with respect to the terms of the Contract. A demand for money or services by a third party is not a Claim.

11. *Contract*--The entire and integrated written agreement between the Owner and Contractor concerning the Work. The Contract supersedes prior negotiations, representations, or agreements, whether written or oral.

12. *Contract Documents*-- Those items so designated in the Agreement. Only printed or hard copies of the items listed in the Agreement are Contract Documents. Approved Shop Drawings, other Contractor's submittals, and the reports and drawings of subsurface and physical conditions are not Contract Documents.

13. *Contract Price*--The moneys payable by Owner to Contractor for completion of the Work in accordance with the Contract Documents as stated in the Agreement (subject to the provisions of Paragraph 11.03 in the case of Unit Price Work).

14. *Contract Times*--The number of days or the dates stated in the Agreement to: (i) achieve Milestones, if any, (ii) achieve Substantial Completion; and (iii) complete the Work so that it is ready for final payment as evidenced by Engineer's written recommendation of final payment.

15. *Contractor*--The individual or entity with whom Owner has entered into the Agreement.

16. *Cost of the Work*--See Paragraph 11.01.A for definition.

17. *Drawings*--That part of the Contract Documents prepared or approved by Engineer which graphically shows the scope, extent, and character of the Work to be performed by Contractor. Shop Drawings and other Contractor submittals are not Drawings as so defined.

18. *Effective Date of the Agreement*--The date indicated in the Agreement on which it becomes effective, but if no such date is indicated, it means the date on which the Agreement is signed and delivered by the last of the two parties to sign and deliver.

19. *Engineer*--The individual or entity named as such in the Agreement.

20. *Field Order*--A written order issued by Engineer which requires minor changes in the Work but which does not involve a change in the Contract Price or the Contract Times.

21. *General Requirements*--Sections of Division 1 of the Specifications. The General Requirements pertain to all sections of the Specifications.

22. *Hazardous Environmental Condition*--The presence at the Site of Asbestos, PCBs, Petroleum, Hazardous Waste, or Radioactive Material in such quantities or circumstances that may present a substantial danger to persons or property exposed thereto in connection with the Work.

23. *Hazardous Waste*--The term Hazardous Waste shall have the meaning provided in Section 1004 of the Solid Waste Disposal Act (42 USC Section 6903) as amended from time to time.

24. *Laws and Regulations; Laws or Regulations*--Any and all applicable laws, rules, regulations, ordinances, codes, and orders of any and all governmental bodies, agencies, authorities, and courts having jurisdiction.

25. *Liens*--Charges, security interests, or encumbrances upon Project funds, real property, or personal property.

26. *Milestone*--A principal event specified in the Contract Documents relating to an intermediate completion date or time prior to Substantial Completion of all the Work.

27. *Notice of Award*--The written notice by Owner to the Successful Bidder stating that upon timely compliance by the Successful Bidder with the conditions precedent listed therein, Owner will sign and deliver the Agreement.

28. *Notice to Proceed*--A written notice given by Owner to Contractor fixing the date on which the Contract Times will commence to run and on which Contractor shall start to perform the Work under the Contract Documents.

29. *Owner*--The individual or entity with whom Contractor has entered into the Agreement and for whom the Work is to be performed.

30. *PCBs*--Polychlorinated biphenyls.

31. *Petroleum*--Petroleum, including crude oil or any fraction thereof which is liquid at standard conditions of temperature and pressure (60 degrees Fahrenheit and 14.7 pounds per square inch absolute), such as oil, petroleum, fuel oil, oil sludge, oil refuse, gasoline, kerosene, and oil mixed with other non-Hazardous Waste and crude oils.

32. *Progress Schedule*--A schedule, prepared and maintained by Contractor, describing the sequence and duration of the activities comprising the Contractor's plan to accomplish the Work within the Contract Times.

33. *Project*--The total construction of which the Work to be performed under the Contract Documents may be the whole, or a part.

34. *Project Manual*--The bound documentary information prepared for bidding and constructing the Work. A listing of the contents of the Project Manual, which may be bound in one or more volumes, is contained in the table(s) of contents.

35. *Radioactive Material*--Source, special nuclear, or byproduct material as defined by the Atomic Energy Act of 1954 (42 USC Section 2011 et seq.) as amended from time to time.

36. *Related Entity* -- An officer, director, partner, employee, agent, consultant, or subcontractor.

37. *Resident Project Representative*--The authorized representative of Engineer who may be assigned to the Site or any part thereof.

38. *Samples*--Physical examples of materials, equipment, or workmanship that are representative of some portion of the Work and which establish the standards by which such portion of the Work will be judged.

39. *Schedule of Submittals*--A schedule, prepared and maintained by Contractor, of required submittals and the time requirements to support scheduled performance of related construction activities.

40. *Schedule of Values*--A schedule, prepared and maintained by Contractor, allocating portions of the Contract Price to various portions of the Work and used as the basis for reviewing Contractor's Applications for Payment.

41. *Shop Drawings*--All drawings, diagrams, illustrations, schedules, and other data or information which are specifically prepared or assembled by or for Contractor and submitted by Contractor to illustrate some portion of the Work.

42. *Site*--Lands or areas indicated in the Contract Documents as being furnished by Owner upon which the Work is to be performed, including rights-of-way and easements for access thereto, and such other lands furnished by Owner which are designated for the use of Contractor.

43. *Specifications*--That part of the Contract Documents consisting of written requirements for materials, equipment, systems, standards and workmanship as applied to the Work, and certain

administrative requirements and procedural matters applicable thereto.

44. *Subcontractor*--An individual or entity having a direct contract with Contractor or with any other Subcontractor for the performance of a part of the Work at the Site.

45. *Substantial Completion*--The time at which the Work (or a specified part thereof) has progressed to the point where, in the opinion of Engineer, the Work (or a specified part thereof) is sufficiently complete, in accordance with the Contract Documents, so that the Work (or a specified part thereof) can be utilized for the purposes for which it is intended. The terms "substantially complete" and "substantially completed" as applied to all or part of the Work refer to Substantial Completion thereof.

46. *Successful Bidder*--The Bidder submitting a responsive Bid to whom Owner makes an award.

47. *Supplementary Conditions*--That part of the Contract Documents which amends or supplements these General Conditions.

48. *Supplier*--A manufacturer, fabricator, supplier, distributor, materialman, or vendor having a direct contract with Contractor or with any Subcontractor to furnish materials or equipment to be incorporated in the Work by Contractor or any Subcontractor.

49. *Underground Facilities*--All underground pipelines, conduits, ducts, cables, wires, manholes, vaults, tanks, tunnels, or other such facilities or attachments, and any encasements containing such facilities, including those that convey electricity, gases, steam, liquid petroleum products, telephone or other communications, cable television, water, wastewater, storm water, other liquids or chemicals, or traffic or other control systems.

50. *Unit Price Work*--Work to be paid for on the basis of unit prices.

51. *Work*--The entire construction or the various separately identifiable parts thereof required to be provided under the Contract Documents. Work includes and is the result of performing or providing all labor, services, and documentation necessary to produce such construction, and furnishing, installing, and incorporating all materials and equipment into such construction, all as required by the Contract Documents.

52. *Work Change Directive*--A written statement to Contractor issued on or after the Effective Date of the Agreement and signed by Owner and recommended by Engineer ordering an addition, deletion, or revision in the Work, or responding to differing or unforeseen subsurface or physical conditions under which the Work is to be performed or to emergencies. A Work Change Directive will not change the Contract Price or the Contract Times

but is evidence that the parties expect that the change ordered or documented by a Work Change Directive will be incorporated in a subsequently issued Change Order following negotiations by the parties as to its effect, if any, on the Contract Price or Contract Times.

1.02 *Terminology*

A. The following words or terms are not defined but, when used in the Bidding Requirements or Contract Documents, have the following meaning.

B. *Intent of Certain Terms or Adjectives*

1. The Contract Documents include the terms "as allowed," "as approved," "as ordered," "as directed" or terms of like effect or import to authorize an exercise of professional judgment by Engineer. In addition, the adjectives "reasonable," "suitable," "acceptable," "proper," "satisfactory," or adjectives of like effect or import are used to describe an action or determination of Engineer as to the Work. It is intended that such exercise of professional judgment, action or determination will be solely to evaluate, in general, the Work for compliance with the requirements of and information in the Contract Documents and conformance with the design concept of the completed Project as a functioning whole as shown or indicated in the Contract Documents (unless there is a specific statement indicating otherwise). The use of any such term or adjective is not intended to and shall not be effective to assign to Engineer any duty or authority to supervise or direct the performance of the Work or any duty or authority to undertake responsibility contrary to the provisions of Paragraph 9.09 or any other provision of the Contract Documents.

C. *Day*

1. The word "day" means a calendar day of 24 hours measured from midnight to the next midnight.

D. *Defective*

1. The word "defective," when modifying the word "Work," refers to Work that is unsatisfactory, faulty, or deficient in that it:

a. does not conform to the Contract Documents, or

b. does not meet the requirements of any applicable inspection, reference standard, test, or approval referred to in the Contract Documents, or

c. has been damaged prior to Engineer's recommendation of final payment (unless responsibility for the protection thereof has been assumed by Owner at Substantial Completion in accordance with Paragraph 14.04 or 14.05).

E. Furnish, Install, Perform, Provide

1. The word "furnish," when used in connection with services, materials, or equipment, shall mean to supply and deliver said services, materials, or equipment to the Site (or some other specified location) ready for use or installation and in usable or operable condition.

2. The word "install," when used in connection with services, materials, or equipment, shall mean to put into use or place in final position said services, materials, or equipment complete and ready for intended use.

3. The words "perform" or "provide," when used in connection with services, materials, or equipment, shall mean to furnish and install said services, materials, or equipment complete and ready for intended use.

4. When "furnish," "install," "perform," or "provide" is not used in connection with services, materials, or equipment in a context clearly requiring an obligation of Contractor, "provide" is implied.

F. Unless stated otherwise in the Contract Documents, words or phrases which have a well-known technical or construction industry or trade meaning are used in the Contract Documents in accordance with such recognized meaning.

ARTICLE 2 - PRELIMINARY MATTERS

2.01 *Delivery of Bonds and Evidence of Insurance*

A. When Contractor delivers the executed counterparts of the Agreement to Owner, Contractor shall also deliver to Owner such bonds as Contractor may be required to furnish.

B. *Evidence of Insurance:* Before any Work at the Site is started, Contractor and Owner shall each deliver to the other, with copies to each additional insured identified in the Supplementary Conditions, certificates of insurance (and other evidence of insurance which either of them or any additional insured may reasonably request) which Contractor and Owner respectively are required to purchase and maintain in accordance with Article 5.

2.02 *Copies of Documents*

A. Owner shall furnish to Contractor up to ten printed or hard copies of the Drawings and Project Manual. Additional copies will be furnished upon request at the cost of reproduction.

2.03 *Commencement of Contract Times; Notice to Proceed*

A. The Contract Times will commence to run on the thirtieth day after the Effective Date of the Agreement

or, if a Notice to Proceed is given, on the day indicated in the Notice to Proceed. A Notice to Proceed may be given at any time within 30 days after the Effective Date of the Agreement. In no event will the Contract Times commence to run later than the sixtieth day after the day of Bid opening or the thirtieth day after the Effective Date of the Agreement, whichever date is earlier.

2.04 *Starting the Work*

A. Contractor shall start to perform the Work on the date when the Contract Times commence to run. No Work shall be done at the Site prior to the date on which the Contract Times commence to run.

2.05 *Before Starting Construction*

A. *Preliminary Schedules:* Within 10 days after the Effective Date of the Agreement (unless otherwise specified in the General Requirements), Contractor shall submit to Engineer for timely review:

1. a preliminary Progress Schedule; indicating the times (numbers of days or dates) for starting and completing the various stages of the Work, including any Milestones specified in the Contract Documents;

2. a preliminary Schedule of Submittals; and

3. a preliminary Schedule of Values for all of the Work which includes quantities and prices of items which when added together equal the Contract Price and subdivides the Work into component parts in sufficient detail to serve as the basis for progress payments during performance of the Work. Such prices will include an appropriate amount of overhead and profit applicable to each item of Work.

2.06 *Preconstruction Conference*

A. Before any Work at the Site is started, a conference attended by Owner, Contractor, Engineer, and others as appropriate will be held to establish a working understanding among the parties as to the Work and to discuss the schedules referred to in Paragraph 2.05.A, procedures for handling Shop Drawings and other submittals, processing Applications for Payment, and maintaining required records.

2.07 *Initial Acceptance of Schedules*

A. At least 10 days before submission of the first Application for Payment a conference attended by Contractor, Engineer, and others as appropriate will be held to review for acceptability to Engineer as provided below the schedules submitted in accordance with Paragraph 2.05.A. Contractor shall have an additional 10 days to make corrections and adjustments and to complete and resubmit the schedules. No progress payment shall be made to Contractor until acceptable schedules are submitted to Engineer.

1. The Progress Schedule will be acceptable to Engineer if it provides an orderly progression of the Work to completion within the Contract Times. Such acceptance will not impose on Engineer responsibility for the Progress Schedule, for sequencing, scheduling, or progress of the Work nor interfere with or relieve Contractor from Contractor's full responsibility therefor.

2. Contractor's Schedule of Submittals will be acceptable to Engineer if it provides a workable arrangement for reviewing and processing the required submittals.

3. Contractor's Schedule of Values will be acceptable to Engineer as to form and substance if it provides a reasonable allocation of the Contract Price to component parts of the Work.

ARTICLE 3 - CONTRACT DOCUMENTS: INTENT, AMENDING, REUSE

3.01 Intent

A. The Contract Documents are complementary; what is required by one is as binding as if required by all.

B. It is the intent of the Contract Documents to describe a functionally complete Project (or part thereof) to be constructed in accordance with the Contract Documents. Any labor, documentation, services, materials, or equipment that may reasonably be inferred from the Contract Documents or from prevailing custom or trade usage as being required to produce the intended result will be provided whether or not specifically called for at no additional cost to Owner.

C. Clarifications and interpretations of the Contract Documents shall be issued by Engineer as provided in Article 9.

3.02 Reference Standards

A. Standards, Specifications, Codes, Laws, and Regulations

1. Reference to standards, specifications, manuals, or codes of any technical society, organization, or association, or to Laws or Regulations, whether such reference be specific or by implication, shall mean the standard, specification, manual, code, or Laws or Regulations in effect at the time of opening of Bids (or on the Effective Date of the Agreement if there were no Bids), except as may be otherwise specifically stated in the Contract Documents.

2. No provision of any such standard, specification, manual or code, or any instruction of a Supplier shall be effective to change the duties or

responsibilities of Owner, Contractor, or Engineer, or any of their subcontractors, consultants, agents, or employees from those set forth in the Contract Documents. No such provision or instruction shall be effective to assign to Owner, or Engineer, or any of, their Related Entities, any duty or authority to supervise or direct the performance of the Work or any duty or authority to undertake responsibility inconsistent with the provisions of the Contract Documents.

3.03 Reporting and Resolving Discrepancies

A. Reporting Discrepancies

1. *Contractor's Review of Contract Documents Before Starting Work:* Before undertaking each part of the Work, Contractor shall carefully study and compare the Contract Documents and check and verify pertinent figures therein and all applicable field measurements. Contractor shall promptly report in writing to Engineer any conflict, error, ambiguity, or discrepancy which Contractor may discover and shall obtain a written interpretation or clarification from Engineer before proceeding with any Work affected thereby.

2. *Contractor's Review of Contract Documents During Performance of Work:* If, during the performance of the Work, Contractor discovers any conflict, error, ambiguity, or discrepancy within the Contract Documents or between the Contract Documents and any provision of any Law or Regulation applicable to the performance of the Work or of any standard, specification, manual or code, or of any instruction of any Supplier, Contractor shall promptly report it to Engineer in writing. Contractor shall not proceed with the Work affected thereby (except in an emergency as required by Paragraph 6.16.A) until an amendment or supplement to the Contract Documents has been issued by one of the methods indicated in Paragraph 3.04.

3. Contractor shall not be liable to Owner or Engineer for failure to report any conflict, error, ambiguity, or discrepancy in the Contract Documents unless Contractor knew or reasonably should have known thereof.

B. Resolving Discrepancies

1. Except as may be otherwise specifically stated in the Contract Documents, the provisions of the Contract Documents shall take precedence in resolving any conflict, error, ambiguity, or discrepancy between the provisions of the Contract Documents and:

a. the provisions of any standard, specification, manual, code, or instruction (whether or not specifically incorporated by reference in the Contract Documents); or

b. the provisions of any Laws or Regulations applicable to the performance of the Work

(unless such an interpretation of the provisions of the Contract Documents would result in violation of such Law or Regulation).

3.04 *Amending and Supplementing Contract Documents*

A. The Contract Documents may be amended to provide for additions, deletions, and revisions in the Work or to modify the terms and conditions thereof by either a Change Order or a Work Change Directive.

B. The requirements of the Contract Documents may be supplemented, and minor variations and deviations in the Work may be authorized, by one or more of the following ways:

1. A Field Order;

2. Engineer's approval of a Shop Drawing or Sample; (Subject to the provisions of Paragraph 6.17.D.3); or

3. Engineer's written interpretation or clarification.

3.05 *Reuse of Documents*

A. Contractor and any Subcontractor or Supplier or other individual or entity performing or furnishing all of the Work under a direct or indirect contract with Contractor, shall not:

1. have or acquire any title to or ownership rights in any of the Drawings, Specifications, or other documents (or copies of any thereof) prepared by or bearing the seal of Engineer or Engineer's consultants, including electronic media editions; or

2. reuse any of such Drawings, Specifications, other documents, or copies thereof on extensions of the Project or any other project without written consent of Owner and Engineer and specific written verification or adaption by Engineer.

B. The prohibition of this Paragraph 3.05 will survive final payment, or termination of the Contract. Nothing herein shall preclude Contractor from retaining copies of the Contract Documents for record purposes.

3.06 *Electronic Data*

A. Copies of data furnished by Owner or Engineer to Contractor or Contractor to Owner or Engineer that may be relied upon are limited to the printed copies (also known as hard copies). Files in electronic media format of text, data, graphics, or other types are furnished only for the convenience of the receiving party. Any conclusion or information obtained or derived from such electronic files will be at the user's

sole risk. If there is a discrepancy between the electronic files and the hard copies, the hard copies govern.

B. Because data stored in electronic media format can deteriorate or be modified inadvertently or otherwise without authorization of the data's creator, the party receiving electronic files agrees that it will perform acceptance tests or procedures within 60 days, after which the receiving party shall be deemed to have accepted the data thus transferred. Any errors detected within the 60-day acceptance period will be corrected by the transferring party.

C. When transferring documents in electronic media format, the transferring party makes no representations as to long term compatibility, usability, or readability of documents resulting from the use of software application packages, operating systems, or computer hardware differing from those used by the data's creator.

ARTICLE 4 - AVAILABILITY OF LANDS; SUBSURFACE AND PHYSICAL CONDITIONS; HAZARDOUS ENVIRONMENTAL CONDITIONS; REFERENCE POINTS

4.01 *Availability of Lands*

A. Owner shall furnish the Site. Owner shall notify Contractor of any encumbrances or restrictions not of general application but specifically related to use of the Site with which Contractor must comply in performing the Work. Owner will obtain in a timely manner and pay for easements for permanent structures or permanent changes in existing facilities. If Contractor and Owner are unable to agree on entitlement to or on the amount or extent, if any, of any adjustment in the Contract Price or Contract Times, or both, as a result of any delay in Owner's furnishing the Site or a part thereof, Contractor may make a Claim therefor as provided in Paragraph 10.05.

B. Upon reasonable written request, Owner shall furnish Contractor with a current statement of record legal title and legal description of the lands upon which the Work is to be performed and Owner's interest therein as necessary for giving notice of or filing a mechanic's or construction lien against such lands in accordance with applicable Laws and Regulations.

C. Contractor shall provide for all additional lands and access thereto that may be required for temporary construction facilities or storage of materials and equipment.

4.02 *Subsurface and Physical Conditions*

A. *Reports and Drawings:* The Supplementary Conditions identify:

1. those reports of explorations and tests of subsurface conditions at or contiguous to the Site that Engineer has used in preparing the Contract Documents; and

2. those drawings of physical conditions in or relating to existing surface or subsurface structures at or contiguous to the Site (except Underground Facilities) that Engineer has used in preparing the Contract Documents.

B. *Limited Reliance by Contractor on Technical Data Authorized:* Contractor may rely upon the general accuracy of the "technical data" contained in such reports and drawings, but such reports and drawings are not Contract Documents. Such "technical data" is identified in the Supplementary Conditions. Except for such reliance on such "technical data," Contractor may not rely upon or make any claim against Owner or Engineer, or any of their Related Entities with respect to:

1. the completeness of such reports and drawings for Contractor's purposes, including, but not limited to, any aspects of the means, methods, techniques, sequences, and procedures of construction to be employed by Contractor, and safety precautions and programs incident thereto; or

2. other data, interpretations, opinions, and information contained in such reports or shown or indicated in such drawings; or

3. any Contractor interpretation of or conclusion drawn from any "technical data" or any such other data, interpretations, opinions, or information.

4.03 *Differing Subsurface or Physical Conditions*

A. *Notice:* If Contractor believes that any subsurface or physical condition at or contiguous to the Site that is uncovered or revealed either:

1. is of such a nature as to establish that any "technical data" on which Contractor is entitled to rely as provided in Paragraph 4.02 is materially inaccurate; or

2. is of such a nature as to require a change in the Contract Documents; or

3. differs materially from that shown or indicated in the Contract Documents; or

4. is of an unusual nature, and differs materially from conditions ordinarily encountered and generally recognized as inherent in work of the character provided for in the Contract Documents;

then Contractor shall, promptly after becoming aware thereof and before further disturbing the subsurface or physical conditions or performing any Work in connection therewith (except in an emergency as required by Paragraph 6.16.A), notify Owner and Engineer in writing about such condition. Contractor shall not further disturb such condition or perform any Work in connection therewith (except as aforesaid) until receipt of written order to do so.

B. *Engineer's Review:* After receipt of written notice as required by Paragraph 4.03.A, Engineer will promptly review the pertinent condition, determine the necessity of Owner's obtaining additional exploration or tests with respect thereto, and advise Owner in writing (with a copy to Contractor) of Engineer's findings and conclusions.

C. *Possible Price and Times Adjustments*

1. The Contract Price or the Contract Times, or both, will be equitably adjusted to the extent that the existence of such differing subsurface or physical condition causes an increase or decrease in Contractor's cost of, or time required for, performance of the Work; subject, however, to the following:

a. such condition must meet any one or more of the categories described in Paragraph 4.03.A; and

b. with respect to Work that is paid for on a Unit Price Basis, any adjustment in Contract Price will be subject to the provisions of Paragraphs 9.07 and 11.03.

2. Contractor shall not be entitled to any adjustment in the Contract Price or Contract Times if:

a. Contractor knew of the existence of such conditions at the time Contractor made a final commitment to Owner with respect to Contract Price and Contract Times by the submission of a Bid or becoming bound under a negotiated contract; or

b. the existence of such condition could reasonably have been discovered or revealed as a result of any examination, investigation, exploration, test, or study of the Site and contiguous areas required by the Bidding Requirements or Contract Documents to be conducted by or for Contractor prior to Contractor's making such final commitment; or

c. Contractor failed to give the written notice as required by Paragraph 4.03.A.

3. If Owner and Contractor are unable to agree on entitlement to or on the amount or extent, if any, of any adjustment in the Contract Price or Contract Times, or both, a Claim may be made therefor as provided in Paragraph 10.05. However, Owner and Engineer, and any of their Related Entities shall not be liable to Contractor for any claims, costs, losses, or damages (including but not limited to all fees and charges of engineers, architects, attorneys, and other professionals and all court or arbitration or other dispute resolution costs) sustained by Contractor on or in connection with any other project or anticipated project.

4.04 *Underground Facilities*

A. *Shown or Indicated:* The information and data shown or indicated in the Contract Documents with respect to existing Underground Facilities at or contiguous to the Site is based on information and data furnished to Owner or Engineer by the owners of such Underground Facilities, including Owner, or by others. Unless it is otherwise expressly provided in the Supplementary Conditions:

1. Owner and Engineer shall not be responsible for the accuracy or completeness of any such information or data; and

2. the cost of all of the following will be included in the Contract Price, and Contractor shall have full responsibility for:

- a. reviewing and checking all such information and data,
- b. locating all Underground Facilities shown or indicated in the Contract Documents,
- c. coordination of the Work with the owners of such Underground Facilities, including Owner, during construction, and
- d. the safety and protection of all such Underground Facilities and repairing any damage thereto resulting from the Work.

B. *Not Shown or Indicated*

1. If an Underground Facility is uncovered or revealed at or contiguous to the Site which was not shown or indicated, or not shown or indicated with reasonable accuracy in the Contract Documents, Contractor shall, promptly after becoming aware thereof and before further disturbing conditions affected thereby or performing any Work in connection therewith (except in an emergency as required by Paragraph 6.16.A), identify the owner of such Underground Facility and give written notice to that owner and to Owner and Engineer. Engineer will

promptly review the Underground Facility and determine the extent, if any, to which a change is required in the Contract Documents to reflect and document the consequences of the existence or location of the Underground Facility. During such time, Contractor shall be responsible for the safety and protection of such Underground Facility.

2. If Engineer concludes that a change in the Contract Documents is required, a Work Change Directive or a Change Order will be issued to reflect and document such consequences. An equitable adjustment shall be made in the Contract Price or Contract Times, or both, to the extent that they are attributable to the existence or location of any Underground Facility that was not shown or indicated or not shown or indicated with reasonable accuracy in the Contract Documents and that Contractor did not know of and could not reasonably have been expected to be aware of or to have anticipated. If Owner and Contractor are unable to agree on entitlement to or on the amount or extent, if any, of any such adjustment in Contract Price or Contract Times, Owner or Contractor may make a Claim therefor as provided in Paragraph 10.05.

4.05 *Reference Points*

A. Owner shall provide engineering surveys to establish reference points for construction which in Engineer's judgment are necessary to enable Contractor to proceed with the Work. Contractor shall be responsible for laying out the Work, shall protect and preserve the established reference points and property monuments, and shall make no changes or relocations without the prior written approval of Owner. Contractor shall report to Engineer whenever any reference point or property monument is lost or destroyed or requires relocation because of necessary changes in grades or locations, and shall be responsible for the accurate replacement or relocation of such reference points or property monuments by professionally qualified personnel.

4.06 *Hazardous Environmental Condition at Site*

A. *Reports and Drawings:* Reference is made to the Supplementary Conditions for the identification of those reports and drawings relating to a Hazardous Environmental Condition identified at the Site, if any, that have been utilized by the Engineer in the preparation of the Contract Documents.

B. *Limited Reliance by Contractor on Technical Data Authorized:* Contractor may rely upon the general accuracy of the "technical data" contained in such reports and drawings, but such reports and drawings are not Contract Documents. Such "technical data" is identified in the Supplementary Conditions. Except for such reliance on such "technical data," Contractor may not rely upon or make any claim against Owner or Engineer, or any of their Related Entities with respect to:

gd

1. the completeness of such reports and drawings for Contractor's purposes, including, but not limited to, any aspects of the means, methods, techniques, sequences and procedures of construction to be employed by Contractor and safety precautions and programs incident thereto; or

2. other data, interpretations, opinions and information contained in such reports or shown or indicated in such drawings; or

3. any Contractor interpretation of or conclusion drawn from any "technical data" or any such other data, interpretations, opinions or information.

C. Contractor shall not be responsible for any Hazardous Environmental Condition uncovered or revealed at the Site which was not shown or indicated in Drawings or Specifications or identified in the Contract Documents to be within the scope of the Work. Contractor shall be responsible for a Hazardous Environmental Condition created with any materials brought to the Site by Contractor, Subcontractors, Suppliers, or anyone else for whom Contractor is responsible.

D. If Contractor encounters a Hazardous Environmental Condition or if Contractor or anyone for whom Contractor is responsible creates a Hazardous Environmental Condition, Contractor shall immediately: (i) secure or otherwise isolate such condition; (ii) stop all Work in connection with such condition and in any area affected thereby (except in an emergency as required by Paragraph 6.16.A); and (iii) notify Owner and Engineer (and promptly thereafter confirm such notice in writing). Owner shall promptly consult with Engineer concerning the necessity for Owner to retain a qualified expert to evaluate such condition or take corrective action, if any.

E. Contractor shall not be required to resume Work in connection with such condition or in any affected area until after Owner has obtained any required permits related thereto and delivered to Contractor written notice: (i) specifying that such condition and any affected area is or has been rendered safe for the resumption of Work; or (ii) specifying any special conditions under which such Work may be resumed safely. If Owner and Contractor cannot agree as to entitlement to or on the amount or extent, if any, of any adjustment in Contract Price or Contract Times, or both, as a result of such Work stoppage or such special conditions under which Work is agreed to be resumed by Contractor, either party may make a Claim therefor as provided in Paragraph 10.05.

F. If after receipt of such written notice Contractor does not agree to resume such Work based on a reasonable belief it is unsafe, or does not agree to resume such Work under such special conditions, then Owner may order the portion of the Work that is in the area affected by such condition to be deleted from the Work. If Owner and Contractor cannot agree as to

entitlement to or on the amount or extent, if any, of an adjustment in Contract Price or Contract Times as a result of deleting such portion of the Work, then either party may make a Claim therefor as provided in Paragraph 10.05. Owner may have such deleted portion of the Work performed by Owner's own forces or others in accordance with Article 7.

G. To the fullest extent permitted by Laws and Regulations, Owner shall indemnify and hold harmless Contractor, Subcontractors, and Engineer, and the officers, directors, partners, employees, agents, consultants, and subcontractors of each and any of them from and against all claims, costs, losses, and damages (including but not limited to all fees and charges of engineers, architects, attorneys, and other professionals and all court or arbitration or other dispute resolution costs) arising out of or relating to a Hazardous Environmental Condition, provided that such Hazardous Environmental Condition: (i) was not shown or indicated in the Drawings or Specifications or identified in the Contract Documents to be included within the scope of the Work, and (ii) was not created by Contractor or by anyone for whom Contractor is responsible. Nothing in this Paragraph 4.06. G shall obligate Owner to indemnify any individual or entity from and against the consequences of that individual's or entity's own negligence.

H. To the fullest extent permitted by Laws and Regulations, Contractor shall indemnify and hold harmless Owner and Engineer, and the officers, directors, partners, employees, agents, consultants, and subcontractors of each and any of them from and against all claims, costs, losses, and damages (including but not limited to all fees and charges of engineers, architects, attorneys, and other professionals and all court or arbitration or other dispute resolution costs) arising out of or relating to a Hazardous Environmental Condition created by Contractor or by anyone for whom Contractor is responsible. Nothing in this Paragraph 4.06.H shall obligate Contractor to indemnify any individual or entity from and against the consequences of that individual's or entity's own negligence.

I. The provisions of Paragraphs 4.02, 4.03, and 4.04 do not apply to a Hazardous Environmental Condition uncovered or revealed at the Site.

ARTICLE 5 - BONDS AND INSURANCE

5.01 *Performance, Payment, and Other Bonds*

A. Contractor shall furnish performance and payment bonds, each in an amount at least equal to the Contract Price as security for the faithful performance and payment of all of Contractor's obligations under the Contract Documents. These bonds shall remain in effect until one year after the date when final payment becomes due or until completion of the correction period specified

in Paragraph 13.07, whichever is later, except as provided otherwise by Laws or Regulations or by the Contract Documents. Contractor shall also furnish such other bonds as are required by the Contract Documents.

B. All bonds shall be in the form prescribed by the Contract Documents except as provided otherwise by Laws or Regulations, and shall be executed by such sureties as are named in the current list of "Companies Holding Certificates of Authority as Acceptable Sureties on Federal Bonds and as Acceptable Reinsuring Companies" as published in Circular 570 (amended) by the Financial Management Service, Surety Bond Branch, U.S. Department of the Treasury. All bonds signed by an agent must be accompanied by a certified copy of the agent's authority to act.

C. If the surety on any bond furnished by Contractor is declared bankrupt or becomes insolvent or its right to do business is terminated in any state where any part of the Project is located or it ceases to meet the requirements of Paragraph 5.01.B, Contractor shall promptly notify Owner and Engineer and shall, within 20 days after the event giving rise to such notification, provide another bond and surety, both of which shall comply with the requirements of Paragraphs 5.01.B and 5.02.

5.02 Licensed Sureties and Insurers

A. All bonds and insurance required by the Contract Documents to be purchased and maintained by Owner or Contractor shall be obtained from surety or insurance companies that are duly licensed or authorized in the jurisdiction in which the Project is located to issue bonds or insurance policies for the limits and coverages so required. Such surety and insurance companies shall also meet such additional requirements and qualifications as may be provided in the Supplementary Conditions.

5.03 Certificates of Insurance

A. Contractor shall deliver to Owner, with copies to each additional insured identified in the Supplementary Conditions, certificates of insurance (and other evidence of insurance requested by Owner or any other additional insured) which Contractor is required to purchase and maintain.

B. Owner shall deliver to Contractor, with copies to each additional insured identified in the Supplementary Conditions, certificates of insurance (and other evidence of insurance requested by Contractor or any other additional insured) which Owner is required to purchase and maintain.

5.04 Contractor's Liability Insurance

A. Contractor shall purchase and maintain such liability and other insurance as is appropriate for the Work being performed and as will provide protection

from claims set forth below which may arise out of or result from Contractor's performance of the Work and Contractor's other obligations under the Contract Documents, whether it is to be performed by Contractor, any Subcontractor or Supplier, or by anyone directly or indirectly employed by any of them to perform any of the Work, or by anyone for whose acts any of them may be liable:

1. claims under workers' compensation, disability benefits, and other similar employee benefit acts;

2. claims for damages because of bodily injury, occupational sickness or disease, or death of Contractor's employees;

3. claims for damages because of bodily injury, sickness or disease, or death of any person other than Contractor's employees;

4. claims for damages insured by reasonably available personal injury liability coverage which are sustained:

a. by any person as a result of an offense directly or indirectly related to the employment of such person by Contractor, or

b. by any other person for any other reason;

5. claims for damages, other than to the Work itself, because of injury to or destruction of tangible property wherever located, including loss of use resulting therefrom; and

6. claims for damages because of bodily injury or death of any person or property damage arising out of the ownership, maintenance or use of any motor vehicle.

B. The policies of insurance required by this Paragraph 5.04 shall:

1. with respect to insurance required by Paragraphs 5.04.A.3 through 5.04.A.6 inclusive, include as additional insured (subject to any customary exclusion regarding professional liability) Owner and Engineer, and any other individuals or entities identified in the Supplementary Conditions, all of whom shall be listed as additional insureds, and include coverage for the respective officers, directors, partners, employees, agents, consultants and subcontractors of each and any of all such additional insureds, and the insurance afforded to these additional insureds shall provide primary coverage for all claims covered thereby;

2. include at least the specific coverages and be written for not less than the limits of liability provided in the Supplementary Conditions or required by Laws or Regulations, whichever is greater;

9

3. include completed operations insurance;
4. include contractual liability insurance covering Contractor's indemnity obligations under Paragraphs 6.11 and 6.20;
5. contain a provision or endorsement that the coverage afforded will not be canceled, materially changed or renewal refused until at least 30 days prior written notice has been given to Owner and Contractor and to each other additional insured identified in the Supplementary Conditions to whom a certificate of insurance has been issued (and the certificates of insurance furnished by the Contractor pursuant to Paragraph 5.03 will so provide);
6. remain in effect at least until final payment and at all times thereafter when Contractor may be correcting, removing, or replacing defective Work in accordance with Paragraph 13.07; and
7. with respect to completed operations insurance, and any insurance coverage written on a claims-made basis, remain in effect for at least two years after final payment.

a. Contractor shall furnish Owner and each other additional insured identified in the Supplementary Conditions, to whom a certificate of insurance has been issued, evidence satisfactory to Owner and any such additional insured of continuation of such insurance at final payment and one year thereafter.

5.05 *Owner's Liability Insurance*

A. In addition to the insurance required to be provided by Contractor under Paragraph 5.04, Owner, at Owner's option, may purchase and maintain at Owner's expense Owner's own liability insurance as will protect Owner against claims which may arise from operations under the Contract Documents.

5.06 *Property Insurance*

A. Unless otherwise provided in the Supplementary Conditions, Owner shall purchase and maintain property insurance upon the Work at the Site in the amount of the full replacement cost thereof (subject to such deductible amounts as may be provided in the Supplementary Conditions or required by Laws and Regulations). This insurance shall:

1. include the interests of Owner, Contractor, Subcontractors, and Engineer, and any other individuals or entities identified in the Supplementary Conditions, and the officers, directors, partners, employees, agents, consultants and subcontractors of each and any of them, each of whom is deemed to have an insurable interest and shall be listed as an insured or additional insured;

2. be written on a Builder's Risk "all-risk" or open peril or special causes of loss policy form that shall at least include insurance for physical loss or damage to the Work, temporary buildings, false work, and materials and equipment in transit, and shall insure against at least the following perils or causes of loss: fire, lightning, extended coverage, theft, vandalism and malicious mischief, earthquake, collapse, debris removal, demolition occasioned by enforcement of Laws and Regulations, water damage, (other than caused by flood) and such other perils or causes of loss as may be specifically required by the Supplementary Conditions;

3. include expenses incurred in the repair or replacement of any insured property (including but not limited to fees and charges of engineers and architects);

4. cover materials and equipment stored at the Site or at another location that was agreed to in writing by Owner prior to being incorporated in the Work, provided that such materials and equipment have been included in an Application for Payment recommended by Engineer;

5. allow for partial utilization of the Work by Owner;

6. include testing and startup; and

7. be maintained in effect until final payment is made unless otherwise agreed to in writing by Owner, Contractor, and Engineer with 30 days written notice to each other additional insured to whom a certificate of insurance has been issued.

B. Owner shall purchase and maintain such boiler and machinery insurance or additional property insurance as may be required by the Supplementary Conditions or Laws and Regulations which will include the interests of Owner, Contractor, Subcontractors, and Engineer, and any other individuals or entities identified in the Supplementary Conditions, and the officers, directors, partners, employees, agents, consultants and subcontractors of each and any of them, each of whom is deemed to have an insurable interest and shall be listed as an insured or additional insured.

C. All the policies of insurance (and the certificates or other evidence thereof) required to be purchased and maintained in accordance with Paragraph 5.06 will contain a provision or endorsement that the coverage afforded will not be canceled or materially changed or renewal refused until at least 30 days prior written notice has been given to Owner and Contractor and to each other additional insured to whom a certificate of insurance has been issued and will contain waiver provisions in accordance with Paragraph 5.07.

D. Owner shall not be responsible for purchasing and maintaining any property insurance specified in this Paragraph 5.06 to protect the interests of Contractor, Subcontractors, or others in the Work to the extent of any

deductible amounts that are identified in the Supplementary Conditions. The risk of loss within such identified deductible amount will be borne by Contractor, Subcontractors, or others suffering any such loss, and if any of them wishes property insurance coverage within the limits of such amounts, each may purchase and maintain it at the purchaser's own expense.

E. If Contractor requests in writing that other special insurance be included in the property insurance policies provided under Paragraph 5.06, Owner shall, if possible, include such insurance, and the cost thereof will be charged to Contractor by appropriate Change Order. Prior to commencement of the Work at the Site, Owner shall in writing advise Contractor whether or not such other insurance has been procured by Owner.

5.07 *Waiver of Rights*

A. Owner and Contractor intend that all policies purchased in accordance with Paragraph 5.06 will protect Owner, Contractor, Subcontractors, and Engineer, and all other individuals or entities identified in the Supplementary Conditions to be listed as insureds or additional insureds (and the officers, directors, partners, employees, agents, consultants and subcontractors of each and any of them) in such policies and will provide primary coverage for all losses and damages caused by the perils or causes of loss covered thereby. All such policies shall contain provisions to the effect that in the event of payment of any loss or damage the insurers will have no rights of recovery against any of the insureds or additional insureds thereunder. Owner and Contractor waive all rights against each other and their respective officers, directors, partners, employees, agents, consultants and subcontractors of each and any of them for all losses and damages caused by, arising out of or resulting from any of the perils or causes of loss covered by such policies and any other property insurance applicable to the Work; and, in addition, waive all such rights against Subcontractors, and Engineer, and all other individuals or entities identified in the Supplementary Conditions to be listed as insured or additional insured (and the officers, directors, partners, employees, agents, consultants and subcontractors of each and any of them) under such policies for losses and damages so caused. None of the above waivers shall extend to the rights that any party making such waiver may have to the proceeds of insurance held by Owner as trustee or otherwise payable under any policy so issued.

B. Owner waives all rights against Contractor, Subcontractors, and Engineer, and the officers, directors, partners, employees, agents, consultants and subcontractors of each and any of them for:

1. loss due to business interruption, loss of use, or other consequential loss extending beyond direct physical loss or damage to Owner's property or the Work caused by, arising out of, or resulting from fire or other perils whether or not insured by Owner; and

2. loss or damage to the completed Project or part thereof caused by, arising out of, or resulting from fire or other insured peril or cause of loss covered by any property insurance maintained on the completed Project or part thereof by Owner during partial utilization pursuant to Paragraph 14.05, after Substantial Completion pursuant to Paragraph 14.04, or after final payment pursuant to Paragraph 14.07.

C. Any insurance policy maintained by Owner covering any loss, damage or consequential loss referred to in Paragraph 5.07.B shall contain provisions to the effect that in the event of payment of any such loss, damage, or consequential loss, the insurers will have no rights of recovery against Contractor, Subcontractors, or Engineer, and the officers, directors, partners, employees, agents, consultants and subcontractors of each and any of them.

5.08 *Receipt and Application of Insurance Proceeds*

A. Any insured loss under the policies of insurance required by Paragraph 5.06 will be adjusted with Owner and made payable to Owner as fiduciary for the insureds, as their interests may appear, subject to the requirements of any applicable mortgage clause and of Paragraph 5.08.B. Owner shall deposit in a separate account any money so received and shall distribute it in accordance with such agreement as the parties in interest may reach. If no other special agreement is reached, the damaged Work shall be repaired or replaced, the moneys so received applied on account thereof, and the Work and the cost thereof covered by an appropriate Change Order.

B. Owner as fiduciary shall have power to adjust and settle any loss with the insurers unless one of the parties in interest shall object in writing within 15 days after the occurrence of loss to Owner's exercise of this power. If such objection be made, Owner as fiduciary shall make settlement with the insurers in accordance with such agreement as the parties in interest may reach. If no such agreement among the parties in interest is reached, Owner as fiduciary shall adjust and settle the loss with the insurers and, if required in writing by any party in interest, Owner as fiduciary shall give bond for the proper performance of such duties.

5.09 *Acceptance of Bonds and Insurance; Option to Replace*

A. If either Owner or Contractor has any objection to the coverage afforded by or other provisions of the bonds or insurance required to be purchased and maintained by the other party in accordance with Article 5 on the basis of non-conformance with the Contract

Documents, the objecting party shall so notify the other party in writing within 10 days after receipt of the certificates (or other evidence requested) required by Paragraph 2.01.B. Owner and Contractor shall each provide to the other such additional information in respect of insurance provided as the other may reasonably request. If either party does not purchase or maintain all of the bonds and insurance required of such party by the Contract Documents, such party shall notify the other party in writing of such failure to purchase prior to the start of the Work, or of such failure to maintain prior to any change in the required coverage. Without prejudice to any other right or remedy, the other party may elect to obtain equivalent bonds or insurance to protect such other party's interests at the expense of the party who was required to provide such coverage, and a Change Order shall be issued to adjust the Contract Price accordingly.

5.10 *Partial Utilization, Acknowledgment of Property Insurer*

A. If Owner finds it necessary to occupy or use a portion or portions of the Work prior to Substantial Completion of all the Work as provided in Paragraph 14.05, no such use or occupancy shall commence before the insurers providing the property insurance pursuant to Paragraph 5.06 have acknowledged notice thereof and in writing effected any changes in coverage necessitated thereby. The insurers providing the property insurance shall consent by endorsement on the policy or policies, but the property insurance shall not be canceled or permitted to lapse on account of any such partial use or occupancy.

ARTICLE 6 - CONTRACTOR'S RESPONSIBILITIES

6.01 *Supervision and Superintendence*

A. Contractor shall supervise, inspect, and direct the Work competently and efficiently, devoting such attention thereto and applying such skills and expertise as may be necessary to perform the Work in accordance with the Contract Documents. Contractor shall be solely responsible for the means, methods, techniques, sequences, and procedures of construction. Contractor shall not be responsible for the negligence of Owner or Engineer in the design or specification of a specific means, method, technique, sequence, or procedure of construction which is shown or indicated in and expressly required by the Contract Documents.

B. At all times during the progress of the Work, Contractor shall assign a competent resident superintendent who shall not be replaced without written notice to Owner and Engineer except under extraordinary circumstances. The superintendent will be Contractor's representative at the Site and shall have authority to act on behalf of Contractor. All communications given to or

received from the superintendent shall be binding on Contractor.

6.02 *Labor; Working Hours*

A. Contractor shall provide competent, suitably qualified personnel to survey and lay out the Work and perform construction as required by the Contract Documents. Contractor shall at all times maintain good discipline and order at the Site.

B. Except as otherwise required for the safety or protection of persons or the Work or property at the Site or adjacent thereto, and except as otherwise stated in the Contract Documents, all Work at the Site shall be performed during regular working hours. Contractor will not permit the performance of Work on a Saturday, Sunday, or any legal holiday without Owner's written consent (which will not be unreasonably withheld) given after prior written notice to Engineer.

6.03 *Services, Materials, and Equipment*

A. Unless otherwise specified in the Contract Documents, Contractor shall provide and assume full responsibility for all services, materials, equipment, labor, transportation, construction equipment and machinery, tools, appliances, fuel, power, light, heat, telephone, water, sanitary facilities, temporary facilities, and all other facilities and incidentals necessary for the performance, testing, start-up, and completion of the Work.

B. All materials and equipment incorporated into the Work shall be as specified or, if not specified, shall be of good quality and new, except as otherwise provided in the Contract Documents. All special warranties and guarantees required by the Specifications shall expressly run to the benefit of Owner. If required by Engineer, Contractor shall furnish satisfactory evidence (including reports of required tests) as to the source, kind, and quality of materials and equipment.

C. All materials and equipment shall be stored, applied, installed, connected, erected, protected, used, cleaned, and conditioned in accordance with instructions of the applicable Supplier, except as otherwise may be provided in the Contract Documents.

6.04 *Progress Schedule*

A. Contractor shall adhere to the Progress Schedule established in accordance with Paragraph 2.07 as it may be adjusted from time to time as provided below.

1. Contractor shall submit to Engineer for acceptance (to the extent indicated in Paragraph 2.07) proposed adjustments in the Progress Schedule that will not result in changing the Contract Times. Such adjustments will comply with any provisions of the General Requirements applicable thereto.

2. Proposed adjustments in the Progress Schedule that will change the Contract Times shall be submitted in accordance with the requirements of Article 12. Adjustments in Contract Times may only be made by a Change Order.

6.05 Substitutes and "Or-Equals"

A. Whenever an item of material or equipment is specified or described in the Contract Documents by using the name of a proprietary item or the name of a particular Supplier, the specification or description is intended to establish the type, function, appearance, and quality required. Unless the specification or description contains or is followed by words reading that no like, equivalent, or "or-equal" item or no substitution is permitted, other items of material or equipment or material or equipment of other Suppliers may be submitted to Engineer for review under the circumstances described below.

1. "Or-Equal" Items: If in Engineer's sole discretion an item of material or equipment proposed by Contractor is functionally equal to that named and sufficiently similar so that no change in related Work will be required, it may be considered by Engineer as an "or-equal" item, in which case review and approval of the proposed item may, in Engineer's sole discretion, be accomplished without compliance with some or all of the requirements for approval of proposed substitute items. For the purposes of this Paragraph 6.05.A.1, a proposed item of material or equipment will be considered functionally equal to an item so named if:

a. in the exercise of reasonable judgment Engineer determines that:

1) it is at least equal in materials of construction, quality, durability, appearance, strength, and design characteristics;

2) it will reliably perform at least equally well the function and achieve the results imposed by the design concept of the completed Project as a functioning whole,

3) it has a proven record of performance and availability of responsive service; and

b. Contractor certifies that, if approved and incorporated into the Work:

1) there will be no increase in cost to the Owner or increase in Contract Times, and

2) it will conform substantially to the detailed requirements of the item named in the Contract Documents.

2. Substitute Items

a. If in Engineer's sole discretion an item of material or equipment proposed by Contractor does not qualify as an "or-equal" item under Paragraph 6.05.A.1, it will be considered a proposed substitute item.

b. Contractor shall submit sufficient information as provided below to allow Engineer to determine that the item of material or equipment proposed is essentially equivalent to that named and an acceptable substitute therefor. Requests for review of proposed substitute items of material or equipment will not be accepted by Engineer from anyone other than Contractor.

c. The requirements for review by Engineer will be as set forth in Paragraph 6.05.A.2.d, as supplemented in the General Requirements and as Engineer may decide is appropriate under the circumstances.

d. Contractor shall make written application to Engineer for review of a proposed substitute item of material or equipment that Contractor seeks to furnish or use. The application:

1) shall certify that the proposed substitute item will:

a) perform adequately the functions and achieve the results called for by the general design,

b) be similar in substance to that specified, and

c) be suited to the same use as that specified;

2) will state:

a) the extent, if any, to which the use of the proposed substitute item will prejudice Contractor's achievement of Substantial Completion on time;

b) whether or not use of the proposed substitute item in the Work will require a change in any of the Contract Documents (or in the provisions of any other direct contract with Owner for other work on the Project) to adapt the design to the proposed substitute item; and

c) whether or not incorporation or use of the proposed substitute item in connection with the Work is subject to payment of any license fee or royalty;

3) will identify:

a) all variations of the proposed substitute item from that specified, and

b) available engineering, sales, maintenance, repair, and replacement services;

4) and shall contain an itemized estimate of all costs or credits that will result directly or indirectly from use of such substitute item, including costs of redesign and claims of other contractors affected by any resulting change,

B. Substitute Construction Methods or Procedures: If a specific means, method, technique, sequence, or procedure of construction is expressly required by the Contract Documents, Contractor may furnish or utilize a substitute means, method, technique, sequence, or procedure of construction approved by Engineer. Contractor shall submit sufficient information to allow Engineer, in Engineer's sole discretion, to determine that the substitute proposed is equivalent to that expressly called for by the Contract Documents. The requirements for review by Engineer will be similar to those provided in Paragraph 6.05.A.2.

C. Engineer's Evaluation: Engineer will be allowed a reasonable time within which to evaluate each proposal or submittal made pursuant to Paragraphs 6.05.A and 6.05.B. Engineer may require Contractor to furnish additional data about the proposed substitute item. Engineer will be the sole judge of acceptability. No "or equal" or substitute will be ordered, installed or utilized until Engineer's review is complete, which will be evidenced by either a Change Order for a substitute or an approved Shop Drawing for an "or equal." Engineer will advise Contractor in writing of any negative determination.

D. Special Guarantee: Owner may require Contractor to furnish at Contractor's expense a special performance guarantee or other surety with respect to any substitute.

E. Engineer's Cost Reimbursement: Engineer will record Engineer's costs in evaluating a substitute proposed or submitted by Contractor pursuant to Paragraphs 6.05.A.2 and 6.05.B. Whether or not Engineer approves a substitute item so proposed or submitted by Contractor, Contractor shall reimburse Owner for the charges of Engineer for evaluating each such proposed substitute. Contractor shall also reimburse Owner for the charges of Engineer for making changes in the Contract

Documents (or in the provisions of any other direct contract with Owner) resulting from the acceptance of each proposed substitute.

F. Contractor's Expense: Contractor shall provide all data in support of any proposed substitute or "or-equal" at Contractor's expense.

6.06 Concerning Subcontractors, Suppliers, and Others

A. Contractor shall not employ any Subcontractor, Supplier, or other individual or entity (including those acceptable to Owner as indicated in Paragraph 6.06.B), whether initially or as a replacement, against whom Owner may have reasonable objection. Contractor shall not be required to employ any Subcontractor, Supplier, or other individual or entity to furnish or perform any of the Work against whom Contractor has reasonable objection.

B. If the Supplementary Conditions require the identity of certain Subcontractors, Suppliers, or other individuals or entities to be submitted to Owner in advance for acceptance by Owner by a specified date prior to the Effective Date of the Agreement, and if Contractor has submitted a list thereof in accordance with the Supplementary Conditions, Owner's acceptance (either in writing or by failing to make written objection thereto by the date indicated for acceptance or objection in the Bidding Documents or the Contract Documents) of any such Subcontractor, Supplier, or other individual or entity so identified may be revoked on the basis of reasonable objection after due investigation. Contractor shall submit an acceptable replacement for the rejected Subcontractor, Supplier, or other individual or entity, and the Contract Price will be adjusted by the difference in the cost occasioned by such replacement, and an appropriate Change Order will be issued. No acceptance by Owner of any such Subcontractor, Supplier, or other individual or entity, whether initially or as a replacement, shall constitute a waiver of any right of Owner or Engineer to reject defective Work.

C. Contractor shall be fully responsible to Owner and Engineer for all acts and omissions of the Subcontractors, Suppliers, and other individuals or entities performing or furnishing any of the Work just as Contractor is responsible for Contractor's own acts and omissions. Nothing in the Contract Documents:

1. shall create for the benefit of any such Subcontractor, Supplier, or other individual or entity any contractual relationship between Owner or Engineer and any such Subcontractor, Supplier or other individual or entity, nor

2. shall anything in the Contract Documents create any obligation on the part of Owner or Engineer to pay or to see to the payment of any moneys due any such Subcontractor, Supplier, or other individual

or entity except as may otherwise be required by Laws and Regulations.

D. Contractor shall be solely responsible for scheduling and coordinating the Work of Subcontractors, Suppliers, and other individuals or entities performing or furnishing any of the Work under a direct or indirect contract with Contractor.

E. Contractor shall require all Subcontractors, Suppliers, and such other individuals or entities performing or furnishing any of the Work to communicate with Engineer through Contractor.

F. The divisions and sections of the Specifications and the identifications of any Drawings shall not control Contractor in dividing the Work among Subcontractors or Suppliers or delineating the Work to be performed by any specific trade.

G. All Work performed for Contractor by a Subcontractor or Supplier will be pursuant to an appropriate agreement between Contractor and the Subcontractor or Supplier which specifically binds the Subcontractor or Supplier to the applicable terms and conditions of the Contract Documents for the benefit of Owner and Engineer. Whenever any such agreement is with a Subcontractor or Supplier who is listed as an additional insured on the property insurance provided in Paragraph 5.06, the agreement between the Contractor and the Subcontractor or Supplier will contain provisions whereby the Subcontractor or Supplier waives all rights against Owner, Contractor, and Engineer, and all other individuals or entities identified in the Supplementary Conditions to be listed as insureds or additional insureds (and the officers, directors, partners, employees, agents, consultants and subcontractors of each and any of them) for all losses and damages caused by, arising out of, relating to, or resulting from any of the perils or causes of loss covered by such policies and any other property insurance applicable to the Work. If the insurers on any such policies require separate waiver forms to be signed by any Subcontractor or Supplier, Contractor will obtain the same.

6.07 *Patent Fees and Royalties*

A. Contractor shall pay all license fees and royalties and assume all costs incident to the use in the performance of the Work or the incorporation in the Work of any invention, design, process, product, or device which is the subject of patent rights or copyrights held by others. If a particular invention, design, process, product, or device is specified in the Contract Documents for use in the performance of the Work and if to the actual knowledge of Owner or Engineer its use is subject to patent rights or copyrights calling for the payment of any license fee or royalty to others, the existence of such rights shall be disclosed by Owner in the Contract Documents.

B. To the fullest extent permitted by Laws and Regulations, Contractor shall indemnify and hold harmless Owner and Engineer, and the officers, directors, partners, employees, agents, consultants and subcontractors of each and any of them from and against all claims, costs, losses, and damages (including but not limited to all fees and charges of engineers, architects, attorneys, and other professionals and all court or arbitration or other dispute resolution costs) arising out of or relating to any infringement of patent rights or copyrights incident to the use in the performance of the Work or resulting from the incorporation in the Work of any invention, design, process, product, or device not specified in the Contract Documents.

6.08 *Permits*

A. Unless otherwise provided in the Supplementary Conditions, Contractor shall obtain and pay for all construction permits and licenses. Owner shall assist Contractor, when necessary, in obtaining such permits and licenses. Contractor shall pay all governmental charges and inspection fees necessary for the prosecution of the Work which are applicable at the time of opening of Bids, or, if there are no Bids, on the Effective Date of the Agreement. Owner shall pay all charges of utility owners for connections for providing permanent service to the Work.

6.09 *Laws and Regulations*

A. Contractor shall give all notices required by and shall comply with all Laws and Regulations applicable to the performance of the Work. Except where otherwise expressly required by applicable Laws and Regulations, neither Owner nor Engineer shall be responsible for monitoring Contractor's compliance with any Laws or Regulations.

B. If Contractor performs any Work knowing or having reason to know that it is contrary to Laws or Regulations, Contractor shall bear all claims, costs, losses, and damages (including but not limited to all fees and charges of engineers, architects, attorneys, and other professionals and all court or arbitration or other dispute resolution costs) arising out of or relating to such Work. However, it shall not be Contractor's primary responsibility to make certain that the Specifications and Drawings are in accordance with Laws and Regulations, but this shall not relieve Contractor of Contractor's obligations under Paragraph 3.03.

C. Changes in Laws or Regulations not known at the time of opening of Bids (or, on the Effective Date of the Agreement if there were no Bids) having an effect on the cost or time of performance of the Work shall be the subject of an adjustment in Contract Price or Contract Times. If Owner and Contractor are unable to agree on entitlement to or on the amount or extent, if any, of any such adjustment, a Claim may be made therefor as provided in Paragraph 10.05.

6.10 Taxes

A. Contractor shall pay all sales, consumer, use, and other similar taxes required to be paid by Contractor in accordance with the Laws and Regulations of the place of the Project which are applicable during the performance of the Work.

6.11 Use of Site and Other Areas

A. Limitation on Use of Site and Other Areas

1. Contractor shall confine construction equipment, the storage of materials and equipment, and the operations of workers to the Site and other areas permitted by Laws and Regulations, and shall not unreasonably encumber the Site and other areas with construction equipment or other materials or equipment. Contractor shall assume full responsibility for any damage to any such land or area, or to the owner or occupant thereof, or of any adjacent land or areas resulting from the performance of the Work.

2. Should any claim be made by any such owner or occupant because of the performance of the Work, Contractor shall promptly settle with such other party by negotiation or otherwise resolve the claim by arbitration or other dispute resolution proceeding or at law.

3. To the fullest extent permitted by Laws and Regulations, Contractor shall indemnify and hold harmless Owner and Engineer, and the officers, directors, partners, employees, agents, consultants and subcontractors of each and any of them from and against all claims, costs, losses, and damages (including but not limited to all fees and charges of engineers, architects, attorneys, and other professionals and all court or arbitration or other dispute resolution costs) arising out of or relating to any claim or action, legal or equitable, brought by any such owner or occupant against Owner, Engineer, or any other party indemnified hereunder to the extent caused by or based upon Contractor's performance of the Work.

B. *Removal of Debris During Performance of the Work:* During the progress of the Work Contractor shall keep the Site and other areas free from accumulations of waste materials, rubbish, and other debris. Removal and disposal of such waste materials, rubbish, and other debris shall conform to applicable Laws and Regulations.

C. *Cleaning:* Prior to Substantial Completion of the Work Contractor shall clean the Site and the Work and make it ready for utilization by Owner. At the completion of the Work Contractor shall remove from the Site all tools, appliances, construction equipment and machinery, and surplus materials and shall restore to original condition all property not designated for alteration by the Contract Documents.

D. *Loading Structures:* Contractor shall not load nor permit any part of any structure to be loaded in any manner that will endanger the structure, nor shall Contractor subject any part of the Work or adjacent property to stresses or pressures that will endanger it.

6.12 Record Documents

A. Contractor shall maintain in a safe place at the Site one record copy of all Drawings, Specifications, Addenda, Change Orders, Work Change Directives, Field Orders, and written interpretations and clarifications in good order and annotated to show changes made during construction. These record documents together with all approved Samples and a counterpart of all approved Shop Drawings will be available to Engineer for reference. Upon completion of the Work, these record documents, Samples, and Shop Drawings will be delivered to Engineer for Owner.

6.13 Safety and Protection

A. Contractor shall be solely responsible for initiating, maintaining and supervising all safety precautions and programs in connection with the Work. Contractor shall take all necessary precautions for the safety of, and shall provide the necessary protection to prevent damage, injury or loss to:

1. all persons on the Site or who may be affected by the Work;

2. all the Work and materials and equipment to be incorporated therein, whether in storage on or off the Site; and

3. other property at the Site or adjacent thereto, including trees, shrubs, lawns, walks, pavements, roadways, structures, utilities, and Underground Facilities not designated for removal, relocation, or replacement in the course of construction.

B. Contractor shall comply with all applicable Laws and Regulations relating to the safety of persons or property, or to the protection of persons or property from damage, injury, or loss; and shall erect and maintain all necessary safeguards for such safety and protection. Contractor shall notify owners of adjacent property and of Underground Facilities and other utility owners when prosecution of the Work may affect them, and shall cooperate with them in the protection, removal, relocation, and replacement of their property.

C. All damage, injury, or loss to any property referred to in Paragraph 6.13.A.2 or 6.13.A.3 caused, directly or indirectly, in whole or in part, by Contractor, any Subcontractor, Supplier, or any other individual or entity directly or indirectly employed by any of them to perform any of the Work, or anyone for whose acts any of them may be liable, shall be remedied by Contractor (except damage or loss attributable to the fault of Draw-

ings or Specifications or to the acts or omissions of Owner or Engineer or , or anyone employed by any of them, or anyone for whose acts any of them may be liable, and not attributable, directly or indirectly, in whole or in part, to the fault or negligence of Contractor or any Subcontractor, Supplier, or other individual or entity directly or indirectly employed by any of them).

D. Contractor's duties and responsibilities for safety and for protection of the Work shall continue until such time as all the Work is completed and Engineer has issued a notice to Owner and Contractor in accordance with Paragraph 14.07.B that the Work is acceptable (except as otherwise expressly provided in connection with Substantial Completion).

6.14 Safety Representative

A. Contractor shall designate a qualified and experienced safety representative at the Site whose duties and responsibilities shall be the prevention of accidents and the maintaining and supervising of safety precautions and programs.

6.15 Hazard Communication Programs

A. Contractor shall be responsible for coordinating any exchange of material safety data sheets or other hazard communication information required to be made available to or exchanged between or among employers at the Site in accordance with Laws or Regulations.

6.16 Emergencies

A. In emergencies affecting the safety or protection of persons or the Work or property at the Site or adjacent thereto, Contractor is obligated to act to prevent threatened damage, injury, or loss. Contractor shall give Engineer prompt written notice if Contractor believes that any significant changes in the Work or variations from the Contract Documents have been caused thereby or are required as a result thereof. If Engineer determines that a change in the Contract Documents is required because of the action taken by Contractor in response to such an emergency, a Work Change Directive or Change Order will be issued.

6.17 Shop Drawings and Samples

A. Contractor shall submit Shop Drawings and Samples to Engineer for review and approval in accordance with the acceptable Schedule of Submittals (as required by Paragraph 2.07). Each submittal will be identified as Engineer may require.

1. Shop Drawings

a. Submit number of copies specified in the General Requirements.

b. Data shown on the Shop Drawings will be complete with respect to quantities, dimensions, specified performance and design criteria, materials, and similar data to show Engineer the services, materials, and equipment Contractor proposes to provide and to enable Engineer to review the information for the limited purposes required by Paragraph 6.17.D.

2. *Samples:* Contractor shall also submit Samples to Engineer for review and approval in accordance with the acceptable schedule of Shop Drawings and Sample submittals.

a. Submit number of Samples specified in the Specifications.

b. Clearly identify each Sample as to material, Supplier, pertinent data such as catalog numbers, the use for which intended and other data as Engineer may require to enable Engineer to review the submittal for the limited purposes required by Paragraph 6.17.D.

B. Where a Shop Drawing or Sample is required by the Contract Documents or the Schedule of Submittals , any related Work performed prior to Engineer's review and approval of the pertinent submittal will be at the sole expense and responsibility of Contractor.

C. Submittal Procedures

1. Before submitting each Shop Drawing or Sample, Contractor shall have determined and verified:

a. all field measurements, quantities, dimensions, specified performance and design criteria, installation requirements, materials, catalog numbers, and similar information with respect thereto;

b. the suitability of all materials with respect to intended use, fabrication, shipping, handling, storage, assembly, and installation pertaining to the performance of the Work;

c. all information relative to Contractor's responsibilities for means, methods, techniques, sequences, and procedures of construction, and safety precautions and programs incident thereto; and

d. shall also have reviewed and coordinated each Shop Drawing or Sample with other Shop Drawings and Samples and with the requirements of the Work and the Contract Documents.

2. Each submittal shall bear a stamp or specific written certification that Contractor has satisfied Contractor's obligations under the Contract Documents

with respect to Contractor's review and approval of that submittal.

3. With each submittal, Contractor shall give Engineer specific written notice of any variations, that the Shop Drawing or Sample may have from the requirements of the Contract Documents. This notice shall be both a written communication separate from the Shop Drawing's or Sample Submittal; and, in addition, by a specific notation made on each Shop Drawing or Sample submitted to Engineer for review and approval of each such variation.

D. Engineer's Review

1. Engineer will provide timely review of Shop Drawings and Samples in accordance with the Schedule of Submittals acceptable to Engineer. Engineer's review and approval will be only to determine if the items covered by the submittals will, after installation or incorporation in the Work, conform to the information given in the Contract Documents and be compatible with the design concept of the completed Project as a functioning whole as indicated by the Contract Documents.

2. Engineer's review and approval will not extend to means, methods, techniques, sequences, or procedures of construction (except where a particular means, method, technique, sequence, or procedure of construction is specifically and expressly called for by the Contract Documents) or to safety precautions or programs incident thereto. The review and approval of a separate item as such will not indicate approval of the assembly in which the item functions.

3. Engineer's review and approval shall not relieve Contractor from responsibility for any variation from the requirements of the Contract Documents unless Contractor has complied with the requirements of Paragraph 6.17.C.3 and Engineer has given written approval of each such variation by specific written notation thereof incorporated in or accompanying the Shop Drawing or Sample. Engineer's review and approval shall not relieve Contractor from responsibility for complying with the requirements of Paragraph 6.17.C.1.

E. Resubmittal Procedures

1. Contractor shall make corrections required by Engineer and shall return the required number of corrected copies of Shop Drawings and submit, as required, new Samples for review and approval. Contractor shall direct specific attention in writing to revisions other than the corrections called for by Engineer on previous submittals.

6.18 Continuing the Work

A. Contractor shall carry on the Work and adhere to the Progress Schedule during all disputes or

disagreements with Owner. No Work shall be delayed or postponed pending resolution of any disputes or disagreements, except as permitted by Paragraph 15.04 or as Owner and Contractor may otherwise agree in writing.

6.19 Contractor's General Warranty and Guarantee

A. Contractor warrants and guarantees to Owner that all Work will be in accordance with the Contract Documents and will not be defective. Engineer and its Related Entities shall be entitled to rely on representation of Contractor's warranty and guarantee.

B. Contractor's warranty and guarantee hereunder excludes defects or damage caused by:

1. abuse, modification, or improper maintenance or operation by persons other than Contractor, Subcontractors, Suppliers, or any other individual or entity for whom Contractor is responsible; or

2. normal wear and tear under normal usage.

C. Contractor's obligation to perform and complete the Work in accordance with the Contract Documents shall be absolute. None of the following will constitute an acceptance of Work that is not in accordance with the Contract Documents or a release of Contractor's obligation to perform the Work in accordance with the Contract Documents:

1. observations by Engineer;

2. recommendation by Engineer or payment by Owner of any progress or final payment;

3. the issuance of a certificate of Substantial Completion by Engineer or any payment related thereto by Owner;

4. use or occupancy of the Work or any part thereof by Owner;

5. any review and approval of a Shop Drawing or Sample submittal or the issuance of a notice of acceptability by Engineer;

6. any inspection, test, or approval by others; or

7. any correction of defective Work by Owner.

6.20 Indemnification

A. To the fullest extent permitted by Laws and Regulations, Contractor shall indemnify and hold harmless Owner and Engineer, and the officers, directors, partners, employees, agents, consultants and subcontractors of each and any of them from and against all claims, costs, losses, and damages (including but not limited to all fees and charges of engineers, architects, attorneys, and other professionals and all court or

arbitration or other dispute resolution costs) arising out of or relating to the performance of the Work, provided that any such claim, cost, loss, or damage is attributable to bodily injury, sickness, disease, or death, or to injury to or destruction of tangible property (other than the Work itself), including the loss of use resulting therefrom but only to the extent caused by any negligent act or omission of Contractor, any Subcontractor, any Supplier, or any individual or entity directly or indirectly employed by any of them to perform any of the Work or anyone for whose acts any of them may be liable.

B. In any and all claims against Owner or Engineer or any of their respective consultants, agents, officers, directors, partners, or employees by any employee (or the survivor or personal representative of such employee) of Contractor, any Subcontractor, any Supplier, or any individual or entity directly or indirectly employed by any of them to perform any of the Work, or anyone for whose acts any of them may be liable, the indemnification obligation under Paragraph 6.20.A shall not be limited in any way by any limitation on the amount or type of damages, compensation, or benefits payable by or for Contractor or any such Subcontractor, Supplier, or other individual or entity under workers' compensation acts, disability benefit acts, or other employee benefit acts.

C. The indemnification obligations of Contractor under Paragraph 6.20.A shall not extend to the liability of Engineer and Engineer's officers, directors, partners, employees, agents, consultants and subcontractors arising out of:

1. the preparation or approval of, or the failure to prepare or approve, maps, Drawings, opinions, reports, surveys, Change Orders, designs, or Specifications; or
2. giving directions or instructions, or failing to give them, if that is the primary cause of the injury or damage.

6.21 *Delegation of Professional Design Services*

A. Contractor will not be required to provide professional design services unless such services are specifically required by the Contract Documents for a portion of the Work or unless such services are required to carry out Contractor's responsibilities for construction means, methods, techniques, sequences and procedures. Contractor shall not be required to provide professional services in violation of applicable law.

B. If professional design services or certifications by a design professional related to systems, materials or equipment are specifically required of Contractor by the Contract Documents, Owner and Engineer will specify all performance and design criteria that such services must satisfy. Contractor shall cause such services or certifications to be provided by a properly licensed professional, whose signature and seal

shall appear on all drawings, calculations, specifications, certifications, Shop Drawings and other submittals prepared by such professional. Shop Drawings and other submittals related to the Work designed or certified by such professional, if prepared by others, shall bear such professional's written approval when submitted to Engineer.

C. Owner and Engineer shall be entitled to rely upon the adequacy, accuracy and completeness of the services, certifications or approvals performed by such design professionals, provided Owner and Engineer have specified to Contractor all performance and design criteria that such services must satisfy.

D. Pursuant to this Paragraph 6.21, Engineer's review and approval of design calculations and design drawings will be only for the limited purpose of checking for conformance with performance and design criteria given and the design concept expressed in the Contract Documents. Engineer's review and approval of Shop Drawings and other submittals (except design calculations and design drawings) will be only for the purpose stated in Paragraph 6.17.D.1.

E. Contractor shall not be responsible for the adequacy of the performance or design criteria required by the Contract Documents.

ARTICLE 7 - OTHER WORK AT THE SITE

7.01 *Related Work at Site*

A. Owner may perform other work related to the Project at the Site with Owner's employees, or via other direct contracts therefor, or have other work performed by utility owners. If such other work is not noted in the Contract Documents, then:

1. written notice thereof will be given to Contractor prior to starting any such other work; and
2. if Owner and Contractor are unable to agree on entitlement to or on the amount or extent, if any, of any adjustment in the Contract Price or Contract Times that should be allowed as a result of such other work, a Claim may be made therefor as provided in Paragraph 10.05.

B. Contractor shall afford each other contractor who is a party to such a direct contract, each utility owner and Owner, if Owner is performing other work with Owner's employees, proper and safe access to the Site, a reasonable opportunity for the introduction and storage of materials and equipment and the execution of such other work, and shall properly coordinate the Work with theirs. Contractor shall do all cutting, fitting, and patching of the Work that may be required to properly connect or otherwise make its several parts come together and

Qob

properly integrate with such other work. Contractor shall not endanger any work of others by cutting, excavating, or otherwise altering their work and will only cut or alter their work with the written consent of Engineer and the others whose work will be affected. The duties and responsibilities of Contractor under this Paragraph are for the benefit of such utility owners and other contractors to the extent that there are comparable provisions for the benefit of Contractor in said direct contracts between Owner and such utility owners and other contractors.

C. If the proper execution or results of any part of Contractor's Work depends upon work performed by others under this Article 7, Contractor shall inspect such other work and promptly report to Engineer in writing any delays, defects, or deficiencies in such other work that render it unavailable or unsuitable for the proper execution and results of Contractor's Work. Contractor's failure to so report will constitute an acceptance of such other work as fit and proper for integration with Contractor's Work except for latent defects and deficiencies in such other work.

7.02 Coordination

A. If Owner intends to contract with others for the performance of other work on the Project at the Site, the following will be set forth in Supplementary Conditions:

1. the individual or entity who will have authority and responsibility for coordination of the activities among the various contractors will be identified;
2. the specific matters to be covered by such authority and responsibility will be itemized; and
3. the extent of such authority and responsibilities will be provided.

B. Unless otherwise provided in the Supplementary Conditions, Owner shall have sole authority and responsibility for such coordination.

7.03 Legal Relationships

A. Paragraphs 7.01.A and 7.02 are not applicable for utilities not under the control of Owner.

B. Each other direct contract of Owner under Paragraph 7.01.A shall provide that the other contractor is liable to Owner and Contractor for the reasonable direct delay and disruption costs incurred by Contractor as a result of the other contractor's actions or inactions.

C. Contractor shall be liable to Owner and any other contractor for the reasonable direct delay and disruption costs incurred by such other contractor as a result of Contractor's action or inactions.

ARTICLE 8 - OWNER'S RESPONSIBILITIES

8.01 Communications to Contractor

A. Except as otherwise provided in these General Conditions, Owner shall issue all communications to Contractor through Engineer.

8.02 Replacement of Engineer

A. In case of termination of the employment of Engineer, Owner shall appoint an engineer to whom Contractor makes no reasonable objection, whose status under the Contract Documents shall be that of the former Engineer.

8.03 Furnish Data

A. Owner shall promptly furnish the data required of Owner under the Contract Documents.

8.04 Pay When Due

A. Owner shall make payments to Contractor when they are due as provided in Paragraphs 14.02.C and 14.07.C.

8.05 Lands and Easements; Reports and Tests

A. Owner's duties in respect of providing lands and easements and providing engineering surveys to establish reference points are set forth in Paragraphs 4.01 and 4.05. Paragraph 4.02 refers to Owner's identifying and making available to Contractor copies of reports of explorations and tests of subsurface conditions and drawings of physical conditions in or relating to existing surface or subsurface structures at or contiguous to the Site that have been utilized by Engineer in preparing the Contract Documents.

8.06 Insurance

A. Owner's responsibilities, if any, in respect to purchasing and maintaining liability and property insurance are set forth in Article 5.

8.07 Change Orders

A. Owner is obligated to execute Change Orders as indicated in Paragraph 10.03.

8.08 Inspections, Tests, and Approvals

A. Owner's responsibility in respect to certain inspections, tests, and approvals is set forth in Paragraph 13.03.B.

8.09 *Limitations on Owner's Responsibilities*

A. The Owner shall not supervise, direct, or have control or authority over, nor be responsible for, Contractor's means, methods, techniques, sequences, or procedures of construction, or the safety precautions and programs incident thereto, or for any failure of Contractor to comply with Laws and Regulations applicable to the performance of the Work. Owner will not be responsible for Contractor's failure to perform the Work in accordance with the Contract Documents.

8.10 *Undisclosed Hazardous Environmental Condition*

A. Owner's responsibility in respect to an undisclosed Hazardous Environmental Condition is set forth in Paragraph 4.06.

8.11 *Evidence of Financial Arrangements*

A. If and to the extent Owner has agreed to furnish Contractor reasonable evidence that financial arrangements have been made to satisfy Owner's obligations under the Contract Documents, Owner's responsibility in respect thereof will be as set forth in the Supplementary Conditions.

ARTICLE 9 - ENGINEER'S STATUS DURING CONSTRUCTION

9.01 *Owner's Representative*

A. Engineer will be Owner's representative during the construction period. The duties and responsibilities and the limitations of authority of Engineer as Owner's representative during construction are set forth in the Contract Documents and will not be changed without written consent of Owner and Engineer.

9.02 *Visits to Site*

A. Engineer will make visits to the Site at intervals appropriate to the various stages of construction as Engineer deems necessary in order to observe as an experienced and qualified design professional the progress that has been made and the quality of the various aspects of Contractor's executed Work. Based on information obtained during such visits and observations, Engineer, for the benefit of Owner, will determine, in general, if the Work is proceeding in accordance with the Contract Documents. Engineer will not be required to make exhaustive or continuous inspections on the Site to check the quality or quantity of the Work. Engineer's efforts will be directed toward providing for Owner a greater degree of confidence that the completed Work will conform generally to the Contract Documents. On the basis of such visits and observations, Engineer will keep

Owner informed of the progress of the Work and will endeavor to guard Owner against defective Work.

B. Engineer's visits and observations are subject to all the limitations on Engineer's authority and responsibility set forth in Paragraph 9.09. Particularly, but without limitation, during or as a result of Engineer's visits or observations of Contractor's Work Engineer will not supervise, direct, control, or have authority over or be responsible for Contractor's means, methods, techniques, sequences, or procedures of construction, or the safety precautions and programs incident thereto, or for any failure of Contractor to comply with Laws and Regulations applicable to the performance of the Work.

9.03 *Project Representative*

A. If Owner and Engineer agree, Engineer will furnish a Resident Project Representative to assist Engineer in providing more extensive observation of the Work. The authority and responsibilities of any such Resident Project Representative and assistants will be as provided in the Supplementary Conditions, and limitations on the responsibilities thereof will be as provided in Paragraph 9.09. If Owner designates another representative or agent to represent Owner at the Site who is not Engineer's consultant, agent or employee, the responsibilities and authority and limitations thereon of such other individual or entity will be as provided in the Supplementary Conditions.

9.04 *Authorized Variations in Work*

A. Engineer may authorize minor variations in the Work from the requirements of the Contract Documents which do not involve an adjustment in the Contract Price or the Contract Times and are compatible with the design concept of the completed Project as a functioning whole as indicated by the Contract Documents. These may be accomplished by a Field Order and will be binding on Owner and also on Contractor, who shall perform the Work involved promptly. If Owner or Contractor believes that a Field Order justifies an adjustment in the Contract Price or Contract Times, or both, and the parties are unable to agree on entitlement to or on the amount or extent, if any, of any such adjustment, a Claim may be made therefor as provided in Paragraph 10.05.

9.05 *Rejecting Defective Work*

A. Engineer will have authority to reject Work which Engineer believes to be defective, or that Engineer believes will not produce a completed Project that conforms to the Contract Documents or that will prejudice the integrity of the design concept of the completed Project as a functioning whole as indicated by the Contract Documents. Engineer will also have authority to require special inspection or testing of the Work as provided in Paragraph 13.04, whether or not the Work is fabricated, installed, or completed.

Ad

9.06 *Shop Drawings, Change Orders and Payments*

A. In connection with Engineer's authority, and limitations thereof, as to Shop Drawings and Samples, see Paragraph 6.17.

B. In connection with Engineer's authority, and limitations thereof, as to design calculations and design drawings submitted in response to a delegation of professional design services, if any, see Paragraph 6.21.

C. In connection with Engineer's authority as to Change Orders, see Articles 10, 11, and 12.

D. In connection with Engineer's authority as to Applications for Payment, see Article 14.

9.07 *Determinations for Unit Price Work*

A. Engineer will determine the actual quantities and classifications of Unit Price Work performed by Contractor. Engineer will review with Contractor the Engineer's preliminary determinations on such matters before rendering a written decision thereon (by recommendation of an Application for Payment or otherwise). Engineer's written decision thereon will be final and binding (except as modified by Engineer to reflect changed factual conditions or more accurate data) upon Owner and Contractor, subject to the provisions of Paragraph 10.05.

9.08 *Decisions on Requirements of Contract Documents and Acceptability of Work*

A. Engineer will be the initial interpreter of the requirements of the Contract Documents and judge of the acceptability of the Work thereunder. All matters in question and other matters between Owner and Contractor arising prior to the date final payment is due relating to the acceptability of the Work, and the interpretation of the requirements of the Contract Documents pertaining to the performance of the Work, will be referred initially to Engineer in writing within 30 days of the event giving rise to the question.

B. Engineer will, with reasonable promptness, render a written decision on the issue referred. If Owner or Contractor believe that any such decision entitles them to an adjustment in the Contract Price or Contract Times or both, a Claim may be made under Paragraph 10.05. The date of Engineer's decision shall be the date of the event giving rise to the issues referenced for the purposes of Paragraph 10.05.B.

C. Engineer's written decision on the issue referred will be final and binding on Owner and Contractor, subject to the provisions of Paragraph 10.05.

D. When functioning as interpreter and judge under this Paragraph 9.08, Engineer will not show

partiality to Owner or Contractor and will not be liable in connection with any interpretation or decision rendered in good faith in such capacity.

9.09 *Limitations on Engineer's Authority and Responsibilities*

A. Neither Engineer's authority or responsibility under this Article 9 or under any other provision of the Contract Documents nor any decision made by Engineer in good faith either to exercise or not exercise such authority or responsibility or the undertaking, exercise, or performance of any authority or responsibility by Engineer shall create, impose, or give rise to any duty in contract, tort, or otherwise owed by Engineer to Contractor, any Subcontractor, any Supplier, any other individual or entity, or to any surety for or employee or agent of any of them.

B. Engineer will not supervise, direct, control, or have authority over or be responsible for Contractor's means, methods, techniques, sequences, or procedures of construction, or the safety precautions and programs incident thereto, or for any failure of Contractor to comply with Laws and Regulations applicable to the performance of the Work. Engineer will not be responsible for Contractor's failure to perform the Work in accordance with the Contract Documents.

C. Engineer will not be responsible for the acts or omissions of Contractor or of any Subcontractor, any Supplier, or of any other individual or entity performing any of the Work.

D. Engineer's review of the final Application for Payment and accompanying documentation and all maintenance and operating instructions, schedules, guarantees, bonds, certificates of inspection, tests and approvals, and other documentation required to be delivered by Paragraph 14.07.A will only be to determine generally that their content complies with the requirements of, and in the case of certificates of inspections, tests, and approvals that the results certified indicate compliance with the Contract Documents.

E. The limitations upon authority and responsibility set forth in this Paragraph 9.09 shall also apply to, the Resident Project Representative, if any, and assistants, if any.

ARTICLE 10 - CHANGES IN THE WORK; CLAIMS

10.01 *Authorized Changes in the Work*

A. Without invalidating the Contract and without notice to any surety, Owner may, at any time or from time to time, order additions, deletions, or revisions in the Work by a Change Order, or a Work Change Directive. Upon receipt of any such document, Contractor shall

promptly proceed with the Work involved which will be performed under the applicable conditions of the Contract Documents (except as otherwise specifically provided).

B. If Owner and Contractor are unable to agree on entitlement to, or on the amount or extent, if any, of an adjustment in the Contract Price or Contract Times, or both, that should be allowed as a result of a Work Change Directive, a Claim may be made therefor as provided in Paragraph 10.05.

10.02 *Unauthorized Changes in the Work*

A. Contractor shall not be entitled to an increase in the Contract Price or an extension of the Contract Times with respect to any work performed that is not required by the Contract Documents as amended, modified, or supplemented as provided in Paragraph 3.04, except in the case of an emergency as provided in Paragraph 6.16 or in the case of uncovering Work as provided in Paragraph 13.04.B.

10.03 *Execution of Change Orders*

A. Owner and Contractor shall execute appropriate Change Orders recommended by Engineer covering:

1. changes in the Work which are: (i) ordered by Owner pursuant to Paragraph 10.01.A, (ii) required because of acceptance of defective Work under Paragraph 13.08.A or Owner's correction of defective Work under Paragraph 13.09, or (iii) agreed to by the parties;

2. changes in the Contract Price or Contract Times which are agreed to by the parties, including any undisputed sum or amount of time for Work actually performed in accordance with a Work Change Directive; and

3. changes in the Contract Price or Contract Times which embody the substance of any written decision rendered by Engineer pursuant to Paragraph 10.05; provided that, in lieu of executing any such Change Order, an appeal may be taken from any such decision in accordance with the provisions of the Contract Documents and applicable Laws and Regulations, but during any such appeal, Contractor shall carry on the Work and adhere to the Progress Schedule as provided in Paragraph 6.18.A.

10.04 *Notification to Surety*

A. If notice of any change affecting the general scope of the Work or the provisions of the Contract Documents (including, but not limited to, Contract Price or Contract Times) is required by the provisions of any bond to be given to a surety, the giving of any such notice will be Contractor's responsibility. The amount of each applicable bond will be adjusted to reflect the effect of any such change.

10.05 *Claims*

A. *Engineer's Decision Required:* All Claims, except those waived pursuant to Paragraph 14.09, shall be referred to the Engineer for decision. A decision by Engineer shall be required as a condition precedent to any exercise by Owner or Contractor of any rights or remedies either may otherwise have under the Contract Documents or by Laws and Regulations in respect of such Claims.

B. *Notice:* Written notice stating the general nature of each Claim, shall be delivered by the claimant to Engineer and the other party to the Contract promptly (but in no event later than 30 days) after the start of the event giving rise thereto. The responsibility to substantiate a Claim shall rest with the party making the Claim. Notice of the amount or extent of the Claim, with supporting data shall be delivered to the Engineer and the other party to the Contract within 60 days after the start of such event (unless Engineer allows additional time for claimant to submit additional or more accurate data in support of such Claim). A Claim for an adjustment in Contract Price shall be prepared in accordance with the provisions of Paragraph 12.01.B. A Claim for an adjustment in Contract Time shall be prepared in accordance with the provisions of Paragraph 12.02.B. Each Claim shall be accompanied by claimant's written statement that the adjustment claimed is the entire adjustment to which the claimant believes it is entitled as a result of said event. The opposing party shall submit any response to Engineer and the claimant within 30 days after receipt of the claimant's last submittal (unless Engineer allows additional time).

C. *Engineer's Action:* Engineer will review each Claim and, within 30 days after receipt of the last submittal of the claimant or the last submittal of the opposing party, if any, take one of the following actions in writing:

1. deny the Claim in whole or in part,

2. approve the Claim, or

3. notify the parties that the Engineer is unable to resolve the Claim if, in the Engineer's sole discretion, it would be inappropriate for the Engineer to do so. For purposes of further resolution of the Claim, such notice shall be deemed a denial.

D. In the event that Engineer does not take action on a Claim within said 30 days, the Claim shall be deemed denied.

E. Engineer's written action under Paragraph 10.05.C or denial pursuant to Paragraphs 10.05.C.3 or 10.05.D will be final and binding upon Owner and Contractor, unless Owner or Contractor invoke the dispute resolution procedure set forth in Article 16 within 30 days of such action or denial.

F. No Claim for an adjustment in Contract Price or Contract Times will be valid if not submitted in accordance with this Paragraph 10.05.

ARTICLE 11 - COST OF THE WORK;
ALLOWANCES; UNIT PRICE WORK

11.01 *Cost of the Work*

A. *Costs Included:* The term Cost of the Work means the sum of all costs, except those excluded in Paragraph 11.01.B, necessarily incurred and paid by Contractor in the proper performance of the Work. When the value of any Work covered by a Change Order or when a Claim for an adjustment in Contract Price is determined on the basis of Cost of the Work, the costs to be reimbursed to Contractor will be only those additional or incremental costs required because of the change in the Work or because of the event giving rise to the Claim. Except as otherwise may be agreed to in writing by Owner, such costs shall be in amounts no higher than those prevailing in the locality of the Project, shall include only the following items, and shall not include any of the costs itemized in Paragraph 11.01.B.

1. Payroll costs for employees in the direct employ of Contractor in the performance of the Work under schedules of job classifications agreed upon by Owner and Contractor. Such employees shall include, without limitation, superintendents, foremen, and other personnel employed full time at the Site. Payroll costs for employees not employed full time on the Work shall be apportioned on the basis of their time spent on the Work. Payroll costs shall include, but not be limited to, salaries and wages plus the cost of fringe benefits, which shall include social security contributions, unemployment, excise, and payroll taxes, workers' compensation, health and retirement benefits, bonuses, sick leave, vacation and holiday pay applicable thereto. The expenses of performing Work outside of regular working hours, on Saturday, Sunday, or legal holidays, shall be included in the above to the extent authorized by Owner.

2. Cost of all materials and equipment furnished and incorporated in the Work, including costs of transportation and storage thereof, and Suppliers' field services required in connection therewith. All cash discounts shall accrue to Contractor unless Owner deposits funds with Contractor with which to make payments, in which case the cash discounts shall accrue to Owner. All trade discounts, rebates and refunds and returns from sale of surplus materials and equipment shall accrue to Owner, and Contractor shall make provisions so that they may be obtained.

3. Payments made by Contractor to Subcontractors for Work performed by Subcontractors. If required by Owner, Contractor shall obtain competitive bids from subcontractors acceptable to Owner and

Contractor and shall deliver such bids to Owner, who will then determine, with the advice of Engineer, which bids, if any, will be acceptable. If any subcontract provides that the Subcontractor is to be paid on the basis of Cost of the Work plus a fee, the Subcontractor's Cost of the Work and fee shall be determined in the same manner as Contractor's Cost of the Work and fee as provided in this Paragraph 11.01.

4. Costs of special consultants (including but not limited to Engineers, architects, testing laboratories, surveyors, attorneys, and accountants) employed for services specifically related to the Work.

5. Supplemental costs including the following:

a. The proportion of necessary transportation, travel, and subsistence expenses of Contractor's employees incurred in discharge of duties connected with the Work.

b. Cost, including transportation and maintenance, of all materials, supplies, equipment, machinery, appliances, office, and temporary facilities at the Site, and hand tools not owned by the workers, which are consumed in the performance of the Work, and cost, less market value, of such items used but not consumed which remain the property of Contractor.

c. Rentals of all construction equipment and machinery, and the parts thereof whether rented from Contractor or others in accordance with rental agreements approved by Owner with the advice of Engineer, and the costs of transportation, loading, unloading, assembly, dismantling, and removal thereof. All such costs shall be in accordance with the terms of said rental agreements. The rental of any such equipment, machinery, or parts shall cease when the use thereof is no longer necessary for the Work.

d. Sales, consumer, use, and other similar taxes related to the Work, and for which Contractor is liable, imposed by Laws and Regulations.

e. Deposits lost for causes other than negligence of Contractor, any Subcontractor, or anyone directly or indirectly employed by any of them or for whose acts any of them may be liable, and royalty payments and fees for permits and licenses.

f. Losses and damages (and related expenses) caused by damage to the Work, not compensated by insurance or otherwise, sustained by Contractor in connection with the performance of the Work (except losses and damages within the deductible amounts of property insurance established in accordance with Paragraph 5.06.D), provided such losses and damages have

resulted from causes other than the negligence of Contractor, any Subcontractor, or anyone directly or indirectly employed by any of them or for whose acts any of them may be liable. Such losses shall include settlements made with the written consent and approval of Owner. No such losses, damages, and expenses shall be included in the Cost of the Work for the purpose of determining Contractor's fee.

g. The cost of utilities, fuel, and sanitary facilities at the Site.

h. Minor expenses such as telegrams, long distance telephone calls, telephone service at the Site, expresses, and similar petty cash items in connection with the Work.

i. The costs of premiums for all bonds and insurance Contractor is required by the Contract Documents to purchase and maintain.

B. *Costs Excluded:* The term Cost of the Work shall not include any of the following items:

1. Payroll costs and other compensation of Contractor's officers, executives, principals (of partnerships and sole proprietorships), general managers, safety managers, engineers, architects, estimators, attorneys, auditors, accountants, purchasing and contracting agents, expeditors, timekeepers, clerks, and other personnel employed by Contractor, whether at the Site or in Contractor's principal or branch office for general administration of the Work and not specifically included in the agreed upon schedule of job classifications referred to in Paragraph 11.01.A.1 or specifically covered by Paragraph 11.01.A.4, all of which are to be considered administrative costs covered by the Contractor's fee.

2. Expenses of Contractor's principal and branch offices other than Contractor's office at the Site.

3. Any part of Contractor's capital expenses, including interest on Contractor's capital employed for the Work and charges against Contractor for delinquent payments.

4. Costs due to the negligence of Contractor, any Subcontractor, or anyone directly or indirectly employed by any of them or for whose acts any of them may be liable, including but not limited to, the correction of defective Work, disposal of materials or equipment wrongly supplied, and making good any damage to property.

5. Other overhead or general expense costs of any kind and the costs of any item not specifically and expressly included in Paragraphs 11.01.A and 11.01.B.

C. *Contractor's Fee:* When all the Work is performed on the basis of cost-plus, Contractor's fee shall

be determined as set forth in the Agreement. When the value of any Work covered by a Change Order or when a Claim for an adjustment in Contract Price is determined on the basis of Cost of the Work, Contractor's fee shall be determined as set forth in Paragraph 12.01.C.

D. *Documentation:* Whenever the Cost of the Work for any purpose is to be determined pursuant to Paragraphs 11.01.A and 11.01.B, Contractor will establish and maintain records thereof in accordance with generally accepted accounting practices and submit in a form acceptable to Engineer an itemized cost breakdown together with supporting data.

11.02 Allowances

A. It is understood that Contractor has included in the Contract Price all allowances so named in the Contract Documents and shall cause the Work so covered to be performed for such sums and by such persons or entities as may be acceptable to Owner and Engineer.

B. Cash Allowances

1. Contractor agrees that:

a. the cash allowances include the cost to Contractor (less any applicable trade discounts) of materials and equipment required by the allowances to be delivered at the Site, and all applicable taxes; and

b. Contractor's costs for unloading and handling on the Site, labor, installation, overhead, profit, and other expenses contemplated for the cash allowances have been included in the Contract Price and not in the allowances, and no demand for additional payment on account of any of the foregoing will be valid.

C. Contingency Allowance

1. Contractor agrees that a contingency allowance, if any, is for the sole use of Owner to cover unanticipated costs.

D. Prior to final payment, an appropriate Change Order will be issued as recommended by Engineer to reflect actual amounts due Contractor on account of Work covered by allowances, and the Contract Price shall be correspondingly adjusted.

11.03 Unit Price Work

A. Where the Contract Documents provide that all or part of the Work is to be Unit Price Work, initially the Contract Price will be deemed to include for all Unit Price Work an amount equal to the sum of the unit price for each separately identified item of Unit Price Work times the estimated quantity of each item as indicated in the Agreement.

41

B. The estimated quantities of items of Unit Price Work are not guaranteed and are solely for the purpose of comparison of Bids and determining an initial Contract Price. Determinations of the actual quantities and classifications of Unit Price Work performed by Contractor will be made by Engineer subject to the provisions of Paragraph 9.07.

C. Each unit price will be deemed to include an amount considered by Contractor to be adequate to cover Contractor's overhead and profit for each separately identified item.

D. Owner or Contractor may make a Claim for an adjustment in the Contract Price in accordance with Paragraph 10.05 if:

1. the quantity of any item of Unit Price Work performed by Contractor differs materially and significantly from the estimated quantity of such item indicated in the Agreement; and

2. there is no corresponding adjustment with respect any other item of Work; and

3. Contractor believes that Contractor is entitled to an increase in Contract Price as a result of having incurred additional expense or Owner believes that Owner is entitled to a decrease in Contract Price and the parties are unable to agree as to the amount of any such increase or decrease.

ARTICLE 12 - CHANGE OF CONTRACT PRICE; CHANGE OF CONTRACT TIMES

12.01 *Change of Contract Price*

A. The Contract Price may only be changed by a Change Order. Any Claim for an adjustment in the Contract Price shall be based on written notice submitted by the party making the Claim to the Engineer and the other party to the Contract in accordance with the provisions of Paragraph 10.05.

B. The value of any Work covered by a Change Order or of any Claim for an adjustment in the Contract Price will be determined as follows:

1. where the Work involved is covered by unit prices contained in the Contract Documents, by application of such unit prices to the quantities of the items involved (subject to the provisions of Paragraph 11.03); or

2. where the Work involved is not covered by unit prices contained in the Contract Documents, by a mutually agreed lump sum (which may include an

allowance for overhead and profit not necessarily in accordance with Paragraph 12.01.C.2); or

3. where the Work involved is not covered by unit prices contained in the Contract Documents and agreement to a lump sum is not reached under Paragraph 12.01.B.2, on the basis of the Cost of the Work (determined as provided in Paragraph 11.01) plus a Contractor's fee for overhead and profit (determined as provided in Paragraph 12.01.C).

C. *Contractor's Fee:* The Contractor's fee for overhead and profit shall be determined as follows:

1. a mutually acceptable fixed fee; or

2. if a fixed fee is not agreed upon, then a fee based on the following percentages of the various portions of the Cost of the Work:

a. for costs incurred under Paragraphs 11.01.A.1 and 11.01.A.2, the Contractor's fee shall be 15 percent;

b. for costs incurred under Paragraph 11.01.A.3, the Contractor's fee shall be five percent;

c. where one or more tiers of subcontracts are on the basis of Cost of the Work plus a fee and no fixed fee is agreed upon, the intent of Paragraph 12.01.C.2.a is that the Subcontractor who actually performs the Work, at whatever tier, will be paid a fee of 15 percent of the costs incurred by such Subcontractor under Paragraphs 11.01.A.1 and 11.01.A.2 and that any higher tier Subcontractor and Contractor will each be paid a fee of five percent of the amount paid to the next lower tier Subcontractor;

d. no fee shall be payable on the basis of costs itemized under Paragraphs 11.01.A.4, 11.01.A.5, and 11.01.B;

e. the amount of credit to be allowed by Contractor to Owner for any change which results in a net decrease in cost will be the amount of the actual net decrease in cost plus a deduction in Contractor's fee by an amount equal to five percent of such net decrease; and

f. when both additions and credits are involved in any one change, the adjustment in Contractor's fee shall be computed on the basis of the net change in accordance with Paragraphs 12.01.C.2.a through 12.01.C.2.e, inclusive.

12.02 *Change of Contract Times*

A. The Contract Times may only be changed by a Change Order. Any Claim for an adjustment in the Contract Times shall be based on written notice submitted

by the party making the Claim to the Engineer and the other party to the Contract in accordance with the provisions of Paragraph 10.05.

B. Any adjustment of the Contract Times covered by a Change Order or any Claim for an adjustment in the Contract Times will be determined in accordance with the provisions of this Article 12.

12.03 Delays

A. Where Contractor is prevented from completing any part of the Work within the Contract Times due to delay beyond the control of Contractor, the Contract Times will be extended in an amount equal to the time lost due to such delay if a Claim is made therefor as provided in Paragraph 12.02.A. Delays beyond the control of Contractor shall include, but not be limited to, acts or neglect by Owner, acts or neglect of utility owners or other contractors performing other work as contemplated by Article 7, fires, floods, epidemics, abnormal weather conditions, or acts of God.

B. If Owner, Engineer, or other contractors or utility owners performing other work for Owner as contemplated by Article 7, or anyone for whom Owner is responsible, delays, disrupts, or interferes with the performance or progress of the Work, then Contractor shall be entitled to an equitable adjustment in the Contract Price or the Contract Times, or both. Contractor's entitlement to an adjustment of the Contract Times is conditioned on such adjustment being essential to Contractor's ability to complete the Work within the Contract Times.

C. If Contractor is delayed in the performance or progress of the Work by fire, flood, epidemic, abnormal weather conditions, acts of God, acts or failures to act of utility owners not under the control of Owner, or other causes not the fault of and beyond control of Owner and Contractor, then Contractor shall be entitled to an equitable adjustment in Contract Times, if such adjustment is essential to Contractor's ability to complete the Work within the Contract Times. Such an adjustment shall be Contractor's sole and exclusive remedy for the delays described in this Paragraph 12.03.C.

D. Owner, Engineer and the Related Entities of each of them shall not be liable to Contractor for any claims, costs, losses, or damages (including but not limited to all fees and charges of Engineers, architects, attorneys, and other professionals and all court or arbitration or other dispute resolution costs) sustained by Contractor on or in connection with any other project or anticipated project.

E. Contractor shall not be entitled to an adjustment in Contract Price or Contract Times for delays within the control of Contractor. Delays attributable to and within the control of a Subcontractor or Supplier shall be deemed to be delays within the control of Contractor.

ARTICLE 13 - TESTS AND INSPECTIONS; CORRECTION, REMOVAL OR ACCEPTANCE OF DEFECTIVE WORK

13.01 Notice of Defects

A. Prompt notice of all defective Work of which Owner or Engineer has actual knowledge will be given to Contractor. All defective Work may be rejected, corrected, or accepted as provided in this Article 13.

13.02 Access to Work

A. Owner, Engineer, their consultants and other representatives and personnel of Owner, independent testing laboratories, and governmental agencies with jurisdictional interests will have access to the Site and the Work at reasonable times for their observation, inspecting, and testing. Contractor shall provide them proper and safe conditions for such access and advise them of Contractor's Site safety procedures and programs so that they may comply therewith as applicable.

13.03 Tests and Inspections

A. Contractor shall give Engineer timely notice of readiness of the Work for all required inspections, tests, or approvals and shall cooperate with inspection and testing personnel to facilitate required inspections or tests.

B. Owner shall employ and pay for the services of an independent testing laboratory to perform all inspections, tests, or approvals required by the Contract Documents except:

1. for inspections, tests, or approvals covered by Paragraphs 13.03.C and 13.03.D below;
2. that costs incurred in connection with tests or inspections conducted pursuant to Paragraph 13.04.B shall be paid as provided in said Paragraph 13.04.C; and
3. as otherwise specifically provided in the Contract Documents.

C. If Laws or Regulations of any public body having jurisdiction require any Work (or part thereof) specifically to be inspected, tested, or approved by an employee or other representative of such public body, Contractor shall assume full responsibility for arranging and obtaining such inspections, tests, or approvals, pay all costs in connection therewith, and furnish Engineer the required certificates of inspection or approval.

D. Contractor shall be responsible for arranging and obtaining and shall pay all costs in connection with any inspections, tests, or approvals required for Owner's and Engineer's acceptance of materials or equipment to

be incorporated in the Work; or acceptance of materials, mix designs, or equipment submitted for approval prior to Contractor's purchase thereof for incorporation in the Work. Such inspections, tests, or approvals shall be performed by organizations acceptable to Owner and Engineer.

E. If any Work (or the work of others) that is to be inspected, tested, or approved is covered by Contractor without written concurrence of Engineer, it must, if requested by Engineer, be uncovered for observation.

F. Uncovering Work as provided in Paragraph 13.03.E shall be at Contractor's expense unless Contractor has given Engineer timely notice of Contractor's intention to cover the same and Engineer has not acted with reasonable promptness in response to such notice.

13.04 *Uncovering Work*

A. If any Work is covered contrary to the written request of Engineer, it must, if requested by Engineer, be uncovered for Engineer's observation and replaced at Contractor's expense.

B. If Engineer considers it necessary or advisable that covered Work be observed by Engineer or inspected or tested by others, Contractor, at Engineer's request, shall uncover, expose, or otherwise make available for observation, inspection, or testing as Engineer may require, that portion of the Work in question, furnishing all necessary labor, material, and equipment.

C. If it is found that the uncovered Work is defective, Contractor shall pay all claims, costs, losses, and damages (including but not limited to all fees and charges of engineers, architects, attorneys, and other professionals and all court or arbitration or other dispute resolution costs) arising out of or relating to such uncovering, exposure, observation, inspection, and testing, and of satisfactory replacement or reconstruction (including but not limited to all costs of repair or replacement of work of others); and Owner shall be entitled to an appropriate decrease in the Contract Price. If the parties are unable to agree as to the amount thereof, Owner may make a Claim therefor as provided in Paragraph 10.05.

D. If, the uncovered Work is not found to be defective, Contractor shall be allowed an increase in the Contract Price or an extension of the Contract Times, or both, directly attributable to such uncovering, exposure, observation, inspection, testing, replacement, and reconstruction. If the parties are unable to agree as to the amount or extent thereof, Contractor may make a Claim therefor as provided in Paragraph 10.05.

13.05 *Owner May Stop the Work*

A. If the Work is defective, or Contractor fails to supply sufficient skilled workers or suitable materials or equipment, or fails to perform the Work in such a way that the completed Work will conform to the Contract Documents, Owner may order Contractor to stop the Work, or any portion thereof, until the cause for such order has been eliminated; however, this right of Owner to stop the Work shall not give rise to any duty on the part of Owner to exercise this right for the benefit of Contractor, any Subcontractor, any Supplier, any other individual or entity, or any surety for, or employee or agent of any of them.

13.06 *Correction or Removal of Defective Work*

A. Promptly after receipt of notice, Contractor shall correct all defective Work, whether or not fabricated, installed, or completed, or, if the Work has been rejected by Engineer, remove it from the Project and replace it with Work that is not defective. Contractor shall pay all claims, costs, losses, and damages (including but not limited to all fees and charges of engineers, architects, attorneys, and other professionals and all court or arbitration or other dispute resolution costs) arising out of or relating to such correction or removal (including but not limited to all costs of repair or replacement of work of others).

B. When correcting defective Work under the terms of this Paragraph 13.06 or Paragraph 13.07, Contractor shall take no action that would void or otherwise impair Owner's special warranty and guarantee, if any, on said Work.

13.07 *Correction Period*

A. If within one year after the date of Substantial Completion (or such longer period of time as may be prescribed by the terms of any applicable special guarantee required by the Contract Documents) or by any specific provision of the Contract Documents, any Work is found to be defective, or if the repair of any damages to the land or areas made available for Contractor's use by Owner or permitted by Laws and Regulations as contemplated in Paragraph 6.11.A is found to be defective, Contractor shall promptly, without cost to Owner and in accordance with Owner's written instructions:

1. repair such defective land or areas; or
2. correct such defective Work; or
3. if the defective Work has been rejected by Owner, remove it from the Project and replace it with Work that is not defective, and
4. satisfactorily correct or repair or remove and replace any damage to other Work, to the work of others or other land or areas resulting therefrom.

B. If Contractor does not promptly comply with the terms of Owner's written instructions, or in an emergency where delay would cause serious risk of loss or damage, Owner may have the defective Work corrected or repaired or may have the rejected Work removed and replaced. All claims, costs, losses, and damages (including but not limited to all fees and charges of engineers, architects, attorneys, and other professionals and all court or arbitration or other dispute resolution costs) arising out of or relating to such correction or repair or such removal and replacement (including but not limited to all costs of repair or replacement of work of others) will be paid by Contractor.

C. In special circumstances where a particular item of equipment is placed in continuous service before Substantial Completion of all the Work, the correction period for that item may start to run from an earlier date if so provided in the Specifications.

D. Where defective Work (and damage to other Work resulting therefrom) has been corrected or removed and replaced under this Paragraph 13.07, the correction period hereunder with respect to such Work will be extended for an additional period of one year after such correction or removal and replacement has been satisfactorily completed.

E. Contractor's obligations under this Paragraph 13.07 are in addition to any other obligation or warranty. The provisions of this Paragraph 13.07 shall not be construed as a substitute for or a waiver of the provisions of any applicable statute of limitation or repose.

13.08 *Acceptance of Defective Work*

A. If, instead of requiring correction or removal and replacement of defective Work, Owner (and, prior to Engineer's recommendation of final payment, Engineer) prefers to accept it, Owner may do so. Contractor shall pay all claims, costs, losses, and damages (including but not limited to all fees and charges of engineers, architects, attorneys, and other professionals and all court or arbitration or other dispute resolution costs) attributable to Owner's evaluation of and determination to accept such defective Work (such costs to be approved by Engineer as to reasonableness) and the diminished value of the Work to the extent not otherwise paid by Contractor pursuant to this sentence. If any such acceptance occurs prior to Engineer's recommendation of final payment, a Change Order will be issued incorporating the necessary revisions in the Contract Documents with respect to the Work, and Owner shall be entitled to an appropriate decrease in the Contract Price, reflecting the diminished value of Work so accepted. If the parties are unable to agree as to the amount thereof, Owner may make a Claim therefor as provided in Paragraph 10.05. If the acceptance occurs after such recommendation, an appropriate amount will be paid by Contractor to Owner.

13.09 *Owner May Correct Defective Work*

A. If Contractor fails within a reasonable time after written notice from Engineer to correct defective Work or to remove and replace rejected Work as required by Engineer in accordance with Paragraph 13.06.A, or if Contractor fails to perform the Work in accordance with the Contract Documents, or if Contractor fails to comply with any other provision of the Contract Documents, Owner may, after seven days written notice to Contractor, correct or remedy any such deficiency.

B. In exercising the rights and remedies under this Paragraph 13.09, Owner shall proceed expeditiously. In connection with such corrective or remedial action, Owner may exclude Contractor from all or part of the Site, take possession of all or part of the Work and suspend Contractor's services related thereto, take possession of Contractor's tools, appliances, construction equipment and machinery at the Site, and incorporate in the Work all materials and equipment stored at the Site or for which Owner has paid Contractor but which are stored elsewhere. Contractor shall allow Owner, Owner's representatives, agents and employees, Owner's other contractors, and Engineer and Engineer's consultants access to the Site to enable Owner to exercise the rights and remedies under this Paragraph.

C. All claims, costs, losses, and damages (including but not limited to all fees and charges of engineers, architects, attorneys, and other professionals and all court or arbitration or other dispute resolution costs) incurred or sustained by Owner in exercising the rights and remedies under this Paragraph 13.09 will be charged against Contractor, and a Change Order will be issued incorporating the necessary revisions in the Contract Documents with respect to the Work; and Owner shall be entitled to an appropriate decrease in the Contract Price. If the parties are unable to agree as to the amount of the adjustment, Owner may make a Claim therefor as provided in Paragraph 10.05. Such claims, costs, losses and damages will include but not be limited to all costs of repair, or replacement of work of others destroyed or damaged by correction, removal, or replacement of Contractor's defective Work.

D. Contractor shall not be allowed an extension of the Contract Times because of any delay in the performance of the Work attributable to the exercise by Owner of Owner's rights and remedies under this Paragraph 13.09.

ARTICLE 14 - PAYMENTS TO CONTRACTOR AND COMPLETION

14.01 *Schedule of Values*

A. The Schedule of Values established as provided in Paragraph 2.07.A will serve as the basis for progress

payments and will be incorporated into a form of Application for Payment acceptable to Engineer. Progress payments on account of Unit Price Work will be based on the number of units completed.

14.02 Progress Payments

A. Applications for Payments

1. At least 20 days before the date established in the Agreement for each progress payment (but not more often than once a month), Contractor shall submit to Engineer for review an Application for Payment filled out and signed by Contractor covering the Work completed as of the date of the Application and accompanied by such supporting documentation as is required by the Contract Documents. If payment is requested on the basis of materials and equipment not incorporated in the Work but delivered and suitably stored at the Site or at another location agreed to in writing, the Application for Payment shall also be accompanied by a bill of sale, invoice, or other documentation warranting that Owner has received the materials and equipment free and clear of all Liens and evidence that the materials and equipment are covered by appropriate property insurance or other arrangements to protect Owner's interest therein, all of which must be satisfactory to Owner.

2. Beginning with the second Application for Payment, each Application shall include an affidavit of Contractor stating that all previous progress payments received on account of the Work have been applied on account to discharge Contractor's legitimate obligations associated with prior Applications for Payment.

3. The amount of retainage with respect to progress payments will be as stipulated in the Agreement.

B. Review of Applications

1. Engineer will, within 10 days after receipt of each Application for Payment, either indicate in writing a recommendation of payment and present the Application to Owner or return the Application to Contractor indicating in writing Engineer's reasons for refusing to recommend payment. In the latter case, Contractor may make the necessary corrections and resubmit the Application.

2. Engineer's recommendation of any payment requested in an Application for Payment will constitute a representation by Engineer to Owner, based on Engineer's observations on the Site of the executed Work as an experienced and qualified design professional and on Engineer's review of the Application for Payment and the accompanying data and schedules, that to the best of Engineer's knowledge, information and belief:

a. the Work has progressed to the point indicated;

b. the quality of the Work is generally in accordance with the Contract Documents (subject to an evaluation of the Work as a functioning whole prior to or upon Substantial Completion, to the results of any subsequent tests called for in the Contract Documents, to a final determination of quantities and classifications for Unit Price Work under Paragraph 9.07, and to any other qualifications stated in the recommendation); and

c. the conditions precedent to Contractor's being entitled to such payment appear to have been fulfilled in so far as it is Engineer's responsibility to observe the Work.

3. By recommending any such payment Engineer will not thereby be deemed to have represented that:

a. inspections made to check the quality or the quantity of the Work as it has been performed have been exhaustive, extended to every aspect of the Work in progress, or involved detailed inspections of the Work beyond the responsibilities specifically assigned to Engineer in the Contract Documents; or

b. that there may not be other matters or issues between the parties that might entitle Contractor to be paid additionally by Owner or entitle Owner to withhold payment to Contractor.

4. Neither Engineer's review of Contractor's Work for the purposes of recommending payments nor Engineer's recommendation of any payment, including final payment, will impose responsibility on Engineer:

a. to supervise, direct, or control the Work, or

b. for the means, methods, techniques, sequences, or procedures of construction, or the safety precautions and programs incident thereto, or

c. for Contractor's failure to comply with Laws and Regulations applicable to Contractor's performance of the Work, or

d. to make any examination to ascertain how or for what purposes Contractor has used the moneys paid on account of the Contract Price, or

e. to determine that title to any of the Work, materials, or equipment has passed to Owner free and clear of any Liens.

5. Engineer may refuse to recommend the whole or any part of any payment if, in Engineer's opinion, it would be incorrect to make the representations to Owner stated in Paragraph 14.02.B.2. Engineer may also refuse to recommend any such payment or, because of subsequently discovered evidence or the results of subsequent

inspections or tests, revise or revoke any such payment recommendation previously made, to such extent as may be necessary in Engineer's opinion to protect Owner from loss because:

- a. the Work is defective, or completed Work has been damaged, requiring correction or replacement;
- b. the Contract Price has been reduced by Change Orders;
- c. Owner has been required to correct defective Work or complete Work in accordance with Paragraph 13.09; or
- d. Engineer has actual knowledge of the occurrence of any of the events enumerated in Paragraph 15.02.A.

C. Payment Becomes Due

1. Ten days after presentation of the Application for Payment to Owner with Engineer's recommendation, the amount recommended will (subject to the provisions of Paragraph 14.02.D) become due, and when due will be paid by Owner to Contractor.

D. Reduction in Payment

1. Owner may refuse to make payment of the full amount recommended by Engineer because:

- a. claims have been made against Owner on account of Contractor's performance or furnishing of the Work;
- b. Liens have been filed in connection with the Work, except where Contractor has delivered a specific bond satisfactory to Owner to secure the satisfaction and discharge of such Liens;
- c. there are other items entitling Owner to a set-off against the amount recommended; or
- d. Owner has actual knowledge of the occurrence of any of the events enumerated in Paragraphs 14.02.B.5.a through 14.02.B.5.c or Paragraph 15.02.A.

2. If Owner refuses to make payment of the full amount recommended by Engineer, Owner will give Contractor immediate written notice (with a copy to Engineer) stating the reasons for such action and promptly pay Contractor any amount remaining after deduction of the amount so withheld. Owner shall promptly pay Contractor the amount so withheld, or any adjustment thereto agreed to by Owner and Contractor, when Contractor corrects to Owner's satisfaction the reasons for such action.

3. If it is subsequently determined that Owner's refusal of payment was not justified, the amount wrongfully withheld shall be treated as an amount due as determined by Paragraph 14.02.C.1.

14.03 Contractor's Warranty of Title

A. Contractor warrants and guarantees that title to all Work, materials, and equipment covered by any Application for Payment, whether incorporated in the Project or not, will pass to Owner no later than the time of payment free and clear of all Liens.

14.04 Substantial Completion

A. When Contractor considers the entire Work ready for its intended use Contractor shall notify Owner and Engineer in writing that the entire Work is substantially complete (except for items specifically listed by Contractor as incomplete) and request that Engineer issue a certificate of Substantial Completion.

B. Promptly after Contractor's notification, Owner, Contractor, and Engineer shall make an inspection of the Work to determine the status of completion. If Engineer does not consider the Work substantially complete, Engineer will notify Contractor in writing giving the reasons therefor.

C. If Engineer considers the Work substantially complete, Engineer will deliver to Owner a tentative certificate of Substantial Completion which shall fix the date of Substantial Completion. There shall be attached to the certificate a tentative list of items to be completed or corrected before final payment. Owner shall have seven days after receipt of the tentative certificate during which to make written objection to Engineer as to any provisions of the certificate or attached list. If, after considering such objections, Engineer concludes that the Work is not substantially complete, Engineer will within 14 days after submission of the tentative certificate to Owner notify Contractor in writing, stating the reasons therefor. If, after consideration of Owner's objections, Engineer considers the Work substantially complete, Engineer will within said 14 days execute and deliver to Owner and Contractor a definitive certificate of Substantial Completion (with a revised tentative list of items to be completed or corrected) reflecting such changes from the tentative certificate as Engineer believes justified after consideration of any objections from Owner.

D. At the time of delivery of the tentative certificate of Substantial Completion, Engineer will deliver to Owner and Contractor a written recommendation as to division of responsibilities pending final payment between Owner and Contractor with respect to security, operation, safety, and protection of the Work, maintenance, heat, utilities, insurance, and warranties and guarantees. Unless Owner and Contractor agree otherwise in writing and so inform Engineer in writing prior to Engineer's issuing the definitive certificate of Substantial

Completion, Engineer's aforesaid recommendation will be binding on Owner and Contractor until final payment.

E. Owner shall have the right to exclude Contractor from the Site after the date of Substantial Completion subject to allowing Contractor reasonable access to complete or correct items on the tentative list.

14.05 *Partial Utilization*

A. Prior to Substantial Completion of all the Work, Owner may use or occupy any substantially completed part of the Work which has specifically been identified in the Contract Documents, or which Owner, Engineer, and Contractor agree constitutes a separately functioning and usable part of the Work that can be used by Owner for its intended purpose without significant interference with Contractor's performance of the remainder of the Work, subject to the following conditions.

1. Owner at any time may request Contractor in writing to permit Owner to use or occupy any such part of the Work which Owner believes to be ready for its intended use and substantially complete. If and when Contractor agrees that such part of the Work is substantially complete, Contractor will certify to Owner and Engineer that such part of the Work is substantially complete and request Engineer to issue a certificate of Substantial Completion for that part of the Work.

2. Contractor at any time may notify Owner and Engineer in writing that Contractor considers any such part of the Work ready for its intended use and substantially complete and request Engineer to issue a certificate of Substantial Completion for that part of the Work.

3. Within a reasonable time after either such request, Owner, Contractor, and Engineer shall make an inspection of that part of the Work to determine its status of completion. If Engineer does not consider that part of the Work to be substantially complete, Engineer will notify Owner and Contractor in writing giving the reasons therefor. If Engineer considers that part of the Work to be substantially complete, the provisions of Paragraph 14.04 will apply with respect to certification of Substantial Completion of that part of the Work and the division of responsibility in respect thereof and access thereto.

4. No use or occupancy or separate operation of part of the Work may occur prior to compliance with the requirements of Paragraph 5.10 regarding property insurance.

14.06 *Final Inspection*

A. Upon written notice from Contractor that the entire Work or an agreed portion thereof is complete, Engineer will promptly make a final inspection with Owner and Contractor and will notify Contractor in writing of all particulars in which this inspection reveals

that the Work is incomplete or defective. Contractor shall immediately take such measures as are necessary to complete such Work or remedy such deficiencies.

14.07 *Final Payment*

A. Application for Payment

1. After Contractor has, in the opinion of Engineer, satisfactorily completed all corrections identified during the final inspection and has delivered, in accordance with the Contract Documents, all maintenance and operating instructions, schedules, guarantees, bonds, certificates or other evidence of insurance certificates of inspection, marked-up record documents (as provided in Paragraph 6.12), and other documents, Contractor may make application for final payment following the procedure for progress payments.

2. The final Application for Payment shall be accompanied (except as previously delivered) by:

- a. all documentation called for in the Contract Documents, including but not limited to the evidence of insurance required by Paragraph 5.04.B.7;
- b. consent of the surety, if any, to final payment;
- c. a list of all Claims against Owner that Contractor believes are unsettled; and
- d. complete and legally effective releases or waivers (satisfactory to Owner) of all Lien rights arising out of or Liens filed in connection with the Work.

3. In lieu of the releases or waivers of Liens specified in Paragraph 14.07.A.2 and as approved by Owner, Contractor may furnish receipts or releases in full and an affidavit of Contractor that: (i) the releases and receipts include all labor, services, material, and equipment for which a Lien could be filed; and (ii) all payrolls, material and equipment bills, and other indebtedness connected with the Work for which Owner or Owner's property might in any way be responsible have been paid or otherwise satisfied. If any Subcontractor or Supplier fails to furnish such a release or receipt in full, Contractor may furnish a bond or other collateral satisfactory to Owner to indemnify Owner against any Lien.

B. *Engineer's Review of Application and Acceptance*

1. If, on the basis of Engineer's observation of the Work during construction and final inspection, and Engineer's review of the final Application for Payment and accompanying documentation as required by the Contract Documents, Engineer is satisfied that the Work has been completed and Contractor's other obligations

under the Contract Documents have been fulfilled, Engineer will, within ten days after receipt of the final Application for Payment, indicate in writing Engineer's recommendation of payment and present the Application for Payment to Owner for payment. At the same time Engineer will also give written notice to Owner and Contractor that the Work is acceptable subject to the provisions of Paragraph 14.09. Otherwise, Engineer will return the Application for Payment to Contractor, indicating in writing the reasons for refusing final payment, in which case Contractor shall make the necessary corrections and resubmit the Application for Payment.

C. Payment Becomes Due

1. Thirty days after the presentation to Owner of the Application for Payment and accompanying documentation, the amount recommended by Engineer, less any sum Owner is entitled to set off against Engineer's recommendation, including but not limited to liquidated damages, will become due and, will be paid by Owner to Contractor.

14.08 Final Completion Delayed

A. If, through no fault of Contractor, final completion of the Work is significantly delayed, and if Engineer so confirms, Owner shall, upon receipt of Contractor's final Application for Payment (for Work fully completed and accepted) and recommendation of Engineer, and without terminating the Contract, make payment of the balance due for that portion of the Work fully completed and accepted. If the remaining balance to be held by Owner for Work not fully completed or corrected is less than the retainage stipulated in the Agreement, and if bonds have been furnished as required in Paragraph 5.01, the written consent of the surety to the payment of the balance due for that portion of the Work fully completed and accepted shall be submitted by Contractor to Engineer with the Application for such payment. Such payment shall be made under the terms and conditions governing final payment, except that it shall not constitute a waiver of Claims.

14.09 Waiver of Claims

A. The making and acceptance of final payment will constitute:

1. a waiver of all Claims by Owner against Contractor, except Claims arising from unsettled Liens, from defective Work appearing after final inspection pursuant to Paragraph 14.06, from failure to comply with the Contract Documents or the terms of any special guarantees specified therein, or from Contractor's continuing obligations under the Contract Documents; and

2. a waiver of all Claims by Contractor against Owner other than those previously made in accordance

with the requirements herein and expressly acknowledged by Owner in writing as still unsettled.

ARTICLE 15 - SUSPENSION OF WORK AND TERMINATION

15.01 Owner May Suspend Work

A. At any time and without cause, Owner may suspend the Work or any portion thereof for a period of not more than 90 consecutive days by notice in writing to Contractor and Engineer which will fix the date on which Work will be resumed. Contractor shall resume the Work on the date so fixed. Contractor shall be granted an adjustment in the Contract Price or an extension of the Contract Times, or both, directly attributable to any such suspension if Contractor makes a Claim therefor as provided in Paragraph 10.05.

15.02 Owner May Terminate for Cause

A. The occurrence of any one or more of the following events will justify termination for cause:

1. Contractor's persistent failure to perform the Work in accordance with the Contract Documents (including, but not limited to, failure to supply sufficient skilled workers or suitable materials or equipment or failure to adhere to the Progress Schedule established under Paragraph 2.07 as adjusted from time to time pursuant to Paragraph 6.04);

2. Contractor's disregard of Laws or Regulations of any public body having jurisdiction;

3. Contractor's disregard of the authority of Engineer; or

4. Contractor's violation in any substantial way of any provisions of the Contract Documents.

B. If one or more of the events identified in Paragraph 15.02.A occur, Owner may, after giving Contractor (and surety) seven days written notice of its intent to terminate the services of Contractor:

1. exclude Contractor from the Site, and take possession of the Work and of all Contractor's tools, appliances, construction equipment, and machinery at the Site, and use the same to the full extent they could be used by Contractor (without liability to Contractor for trespass or conversion),

2. incorporate in the Work all materials and equipment stored at the Site or for which Owner has paid Contractor but which are stored elsewhere, and

ok

3. complete the Work as Owner may deem expedient.

C. If Owner proceeds as provided in Paragraph 15.02.B, Contractor shall not be entitled to receive any further payment until the Work is completed. If the unpaid balance of the Contract Price exceeds all claims, costs, losses, and damages (including but not limited to all fees and charges of engineers, architects, attorneys, and other professionals and all court or arbitration or other dispute resolution costs) sustained by Owner arising out of or relating to completing the Work, such excess will be paid to Contractor. If such claims, costs, losses, and damages exceed such unpaid balance, Contractor shall pay the difference to Owner. Such claims, costs, losses, and damages incurred by Owner will be reviewed by Engineer as to their reasonableness and, when so approved by Engineer, incorporated in a Change Order. When exercising any rights or remedies under this Paragraph Owner shall not be required to obtain the lowest price for the Work performed.

D. Notwithstanding Paragraphs 15.02.B and 15.02.C, Contractor's services will not be terminated if Contractor begins within seven days of receipt of notice of intent to terminate to correct its failure to perform and proceeds diligently to cure such failure within no more than 30 days of receipt of said notice.

E. Where Contractor's services have been so terminated by Owner, the termination will not affect any rights or remedies of Owner against Contractor then existing or which may thereafter accrue. Any retention or payment of moneys due Contractor by Owner will not release Contractor from liability.

F. If and to the extent that Contractor has provided a performance bond under the provisions of Paragraph 5.01.A, the termination procedures of that bond shall supersede the provisions of Paragraphs 15.02.B, and 15.02.C.

15.03 *Owner May Terminate For Convenience*

A. Upon seven days written notice to Contractor and Engineer, Owner may, without cause and without prejudice to any other right or remedy of Owner, terminate the Contract. In such case, Contractor shall be paid for (without duplication of any items):

1. completed and acceptable Work executed in accordance with the Contract Documents prior to the effective date of termination, including fair and reasonable sums for overhead and profit on such Work;

2. expenses sustained prior to the effective date of termination in performing services and furnishing labor, materials, or equipment as required by the Contract Documents in connection with uncompleted Work, plus fair and reasonable sums for overhead and profit on such expenses;

3. all claims, costs, losses, and damages (including but not limited to all fees and charges of engineers, architects, attorneys, and other professionals and all court or arbitration or other dispute resolution costs) incurred in settlement of terminated contracts with Subcontractors, Suppliers, and others; and

4. reasonable expenses directly attributable to termination.

B. Contractor shall not be paid on account of loss of anticipated profits or revenue or other economic loss arising out of or resulting from such termination.

15.04 *Contractor May Stop Work or Terminate*

A. If, through no act or fault of Contractor, (i) the Work is suspended for more than 90 consecutive days by Owner or under an order of court or other public authority, or (ii) Engineer fails to act on any Application for Payment within 30 days after it is submitted, or (iii) Owner fails for 30 days to pay Contractor any sum finally determined to be due, then Contractor may, upon seven days written notice to Owner and Engineer, and provided Owner or Engineer do not remedy such suspension or failure within that time, terminate the Contract and recover from Owner payment on the same terms as provided in Paragraph 15.03.

B. In lieu of terminating the Contract and without prejudice to any other right or remedy, if Engineer has failed to act on an Application for Payment within 30 days after it is submitted, or Owner has failed for 30 days to pay Contractor any sum finally determined to be due, Contractor may, seven days after written notice to Owner and Engineer, stop the Work until payment is made of all such amounts due Contractor, including interest thereon. The provisions of this Paragraph 15.04 are not intended to preclude Contractor from making a Claim under Paragraph 10.05 for an adjustment in Contract Price or Contract Times or otherwise for expenses or damage directly attributable to Contractor's stopping the Work as permitted by this Paragraph.

ARTICLE 16 - DISPUTE RESOLUTION

16.01 *Methods and Procedures*

A. Either Owner or Contractor may request mediation of any Claim submitted to Engineer for a decision under Paragraph 10.05 before such decision becomes final and binding. The mediation will be

governed by the Construction Industry Mediation Rules of the American Arbitration Association in effect as of the Effective Date of the Agreement. The request for mediation shall be submitted in writing to the American Arbitration Association and the other party to the Contract. Timely submission of the request shall stay the effect of Paragraph 10.05.E.

B. Owner and Contractor shall participate in the mediation process in good faith. The process shall be concluded within 60 days of filing of the request. The date of termination of the mediation shall be determined by application of the mediation rules referenced above.

C. If the Claim is not resolved by mediation, Engineer's action under Paragraph 10.05.C or a denial pursuant to Paragraphs 10.05.C.3 or 10.05.D shall become final and binding 30 days after termination of the mediation unless, within that time period, Owner or Contractor:

1. elects in writing to invoke any dispute resolution process provided for in the Supplementary Conditions, or

2. agrees with the other party to submit the Claim to another dispute resolution process, or

3. gives written notice to the other party of their intent to submit the Claim to a court of competent jurisdiction.

ARTICLE 17 - MISCELLANEOUS

17.01 *Giving Notice*

A. Whenever any provision of the Contract Documents requires the giving of written notice, it will be deemed to have been validly given if:

1. delivered in person to the individual or to a member of the firm or to an officer of the corporation for whom it is intended, or

2. delivered at or sent by registered or certified mail, postage prepaid, to the last business address known to the giver of the notice.

17.02 *Computation of Times*

A. When any period of time is referred to in the Contract Documents by days, it will be computed to exclude the first and include the last day of such period. If the last day of any such period falls on a Saturday or Sunday or on a day made a legal holiday by the law of the applicable jurisdiction, such day will be omitted from the computation.

17.03 *Cumulative Remedies*

A. The duties and obligations imposed by these General Conditions and the rights and remedies available hereunder to the parties hereto are in addition to, and are not to be construed in any way as a limitation of, any rights and remedies available to any or all of them which are otherwise imposed or available by Laws or Regulations, by special warranty or guarantee, or by other provisions of the Contract Documents. The provisions of this Paragraph will be as effective as if repeated specifically in the Contract Documents in connection with each particular duty, obligation, right, and remedy to which they apply.

17.04 *Survival of Obligations*

A. All representations, indemnifications, warranties, and guarantees made in, required by, or given in accordance with the Contract Documents, as well as all continuing obligations indicated in the Contract Documents, will survive final payment, completion, and acceptance of the Work or termination or completion of the Contract or termination of the services of Contractor.

17.05 *Controlling Law*

A. This Contract is to be governed by the law of the state in which the Project is located.

17.06 *Headings*

A. Article and paragraph headings are inserted for convenience only and do not constitute parts of these General Conditions.

SUPPLEMENTARY CONDITIONS

These Supplementary Conditions amend or supplement the Standard General Conditions of the Construction Contract (No. C-700) and other provisions of the Contract Documents as indicated below. All provisions which are not so amended or supplemented remain in full force and effect:

SC-4.02 Delete Paragraphs 4.02.A and 4.02.B in their entirety and insert the following:

- A. No Geotechnical Report is known to Owner or Engineer.

SC-4.06 Delete Paragraphs 4.06.A and 4.06.B in their entirety and insert the following:

- A. No reports or drawings related to Hazardous Environmental Conditions are known to Owner or Engineer.
- B. Left Blank Intentionally.

SC-5.04 Add the following new paragraph immediately after Paragraph 5.04.B:

CONTRACTOR'S Insurance. Before commencing the work, and as a condition of payment, the CONTRACTOR shall purchase and maintain insurance that will protect it from the claims arising out of its operations under this Agreement, whether the operations are by the CONTRACTOR, or any of its consultants or subcontractors or anyone directly or indirectly employed by any of them, or by anyone for whose acts any of them may be liable.

C. Minimum Limits of Liability. The CONTRACTOR shall maintain insurance with limits of liability equal to the limits of liability as set forth below.

1. Workers Compensation

- A. Statutory Workers Compensation Benefits
- B. Employer Liability:
 - Bodily Injury by Accident - \$1,000,000 Each Accident
 - Bodily Injury by Disease - \$1,000,000 Policy Limit
 - Bodily Injury by Disease - \$1,000,000 Each Employee

2. Commercial General Liability

\$1,000,000 Combined Single Limit of Bodily Injury
Liability and Property Damage Liability Per Occurrence

\$2,000,000 General Aggregate Limit
\$2,000,000 Products & Completed Operations Aggregate Limit
\$1,000,000 Personal and Advertising Injury Limit

Products and Completed Operations Coverage must be maintained for not less than two full years after final payment.

3. Business Auto Liability

- A. \$1,000,000 Combined Single Limit of Bodily Injury Liability and Property Damage Liability

4. Excess Liability

- A. \$2,000,000 Each Occurrence Limit
\$2,000,000 Aggregate Limit

D. Number of Policies. Commercial General Liability Insurance and other liability insurance may be arranged under a single policy for the full limits required or by a combination of underlying policies with the balance provided by an Excess or Umbrella Liability Policy.

E. Additional Insured. The CONTRACTOR shall endorse all policies identified in Subparagraph 5.04(C) (with the exception of Workers Compensation) to name Owner as an Additional Insured. On the Commercial General Liability Policy, the Owner shall be given Additional Insured status for BOTH the ongoing operations of the CONTRACTOR and the completed operations of the CONTRACTOR. Also, the coverage provided to the Owner as an Additional Insured shall be written on a Primary Basis.

F. Waiver of Subrogation Endorsements. The CONTRACTOR shall endorse all policies identified in Subparagraph 5.04(C) with a Waiver of Subrogation in favor of the Owner. The CONTRACTOR shall also require similar waivers from its subcontractors in favor of the CONTRACTOR and Owner.

G. Acceptable Insurance Companies. The CONTRACTOR shall maintain in effect all insurance coverages under this Agreement at the CONTRACTOR'S sole expense and with insurance companies acceptable to the Owner and which have an A. M. Best Company rating of A- VII or better.

H. Notice of Cancellation or Non-Renewal. The CONTRACTOR'S insurance policies identified in Subparagraph 5.04(C) shall contain a provision that coverage will not be cancelled or non-renewed until at least thirty (30) days' prior written notice has been given to the Owner.

I. Certificates of Insurance. Certificates of insurance showing required coverage to be in force pursuant to Subparagraph 5.04(C) shall be filed with the Owner prior to commencement of the CONTRACTOR'S work. In the event the CONTRACTOR fails to obtain or maintain any insurance coverage required under this Agreement, the Owner may purchase such coverage as desired for Owner's benefit and charge the expense to the CONTRACTOR, or terminate this Agreement.

J. Continuation of Coverage. The CONTRACTOR shall continue to carry Completed Operations Liability Insurance for at least two years after either ninety (90) days following substantial completion of the work or final payment to the CONTRACTOR, whichever is earlier. The CONTRACTOR shall furnish the Owner evidence of such insurance at final payment and one year from final payment.



SC-5.06.A. Delete Paragraph 5.06.A in its entirety and insert the following in its place:

A. Contractor shall purchase and maintain property insurance upon the Work at the Site in the amount of the full replacement cost thereof.

1. This insurance shall:

a. include the interests of Owner, Contractor, Subcontractors, Engineer and any other individuals or entities identified herein, and the officers, directors, partners, employees, agents and other consultants and subcontractors of any of them each of whom is deemed to have an insurable interest and shall be listed as an insured or additional insured;

b. be written on a Builder's Risk "all-risk" or open peril or special causes of loss policy form that shall at least include insurance for physical loss and damage to the Work, temporary buildings, falsework, and materials and equipment in transit and shall insure against at least the following perils or causes of loss: fire, lightning, extended coverage, theft, vandalism and malicious mischief, earthquake, collapse, debris removal, demolition occasioned by enforcement of Laws and Regulations, water damage (other than that caused by flood), and such other perils or causes of loss as may be specifically required by the Supplementary Conditions;

c. include expenses incurred in the repair or replacement of any insured property (including but not limited to fees and charges of engineers and architects);

d. cover materials and equipment stored at the Site or at another location that was agreed to in writing by Owner prior to being incorporated in the Work, provided that such materials and equipment have been included in an Application for Payment recommended by Engineer;

e. allow for partial utilization of the Work by Owner;

f. include testing and startup; and

g. be maintained in effect until final payment is made unless otherwise agreed to in writing by Owner, Contractor and Engineer with 30 days written notice to each other additional insured to whom a certificate of insurance has been issued.

2. Contractor shall be responsible for any deductible or self-insured retention.

3. The policies of insurance required to be purchased and maintained by Contractor in accordance with this Paragraph SC-5.06.A shall comply with the requirements of paragraph 5.06.C of the General Conditions.

SC-5.06.E. Delete Paragraph GC-5.06.E in its entirety.

SC-6.02 Add a new sentence immediately after Paragraph 6.02A:

A1. The scope of Contractor's work does not require a need for line and grade staking. The Engineer will provide direction for locations of work, one time, on behalf of the Owner, and at no expense to the Contractor, if required.

SC-6.10 Add a new paragraph immediately after Paragraph 6.10.A:

B. Owner is exempt from payment of sales and compensating use taxes of the Texas and of cities and counties thereof on all materials to be incorporated into the public streets, drainage, and sanitary sewer portions of the Work.

1. Owner will furnish the required certificates of tax exemption to Contractor for use in the purchase of supplies and materials to be incorporated into the Work.

2. Owner's exemption does not apply to construction tools, machinery, equipment, or other property purchased by or leased by Contractor, or to supplies or materials not incorporated into the Work.

SC-7.04 Claims Between Contractors

A. Should Contractor cause damage to the work or property of any other contractor at the Site, or should any claim arising out of Contractor's performance of the Work at the Site be made by any other contractor against Contractor, Owner, Engineer, or the construction coordinator, Contractor shall promptly attempt to settle with such other contractor by agreement, or to otherwise resolve the dispute by arbitration or at law.

B. Contractor shall, to the fullest extent permitted by Laws and Regulations, indemnify and hold harmless Owner, Engineer, the construction coordinator and the officers, directors, partners, employees, agents and other consultants and subcontractors of each and any of them from and against all claims, costs, losses and damages (including, but not limited to, fees and charges of engineers, architects, attorneys, and other professionals and court and arbitration costs) arising directly, indirectly or consequentially out of any action, legal or equitable, brought by any other contractor against Owner, Engineer, Engineer's Consultants, or the construction coordinator to the extent said claim is based on or arises out of Contractor's performance of the Work. Should another contractor cause damage to the Work or property of Contractor or should the performance of work by any other contractor at the Site give rise to any other Claim, Contractor shall not institute any action, legal or equitable, against Owner, Engineer, or the construction coordinator or permit any action against any of them to be maintained and continued in its name or for its benefit in any court or before any arbiter which seeks to impose liability on or to recover damages from Owner, Engineer, or the construction coordinator on account of any such damage or Claim.

C. If Contractor is delayed at any time in performing or furnishing Work by any act or neglect of another contractor, and Owner and Contractor are unable to agree as to the extent of any adjustment in Contract Times attributable thereto, Contractor may make a Claim for an extension of times in accordance with Article 12. An extension of the Contract Times shall be Contractor's exclusive

08

remedy with respect to Owner, Engineer, and construction coordinator for any delay, disruption, interference, or hindrance caused by any other contractor. This paragraph does not prevent recovery from Owner, Engineer, or construction coordinator for activities that are their respective responsibilities.

ad

SECTION 00 83 00

WAGE RATES & PAYROLL REPORTING

1. PAYMENT

A. Classification Definitions, Building and Highway-Heavy

Definitions for Building Construction and Highway-Heavy classifications shall conform to the current "Dictionary of Occupational Titles" as published by the U.S. Department of Labor.

B. Minimum Wages

Workers on Project shall be paid not less than wage rates, including fringe benefits, as published by the Department of Labor (DOL) for Building Construction and Highway Heavy Trades. Such wage rates shall be used throughout the Contract. If a classification is to be used, which is not listed in the attached wage rates, Contractor shall submit to Owner rates and classification proposed for use, for approval, prior to performance of Work.

NOTE: The terms journeyman and apprentice apply to both union and independent workers, and are not intended to imply that these positions are union workers only.

All laborers and mechanics working upon the Work for this Project shall be paid unconditionally and without subsequent deduction or rebate on any account (except such payroll deductions as are permitted by regulations issued by Secretary of Labor under the Copeland Act, Title 29 CFR, Part 3) full wages accrued and when due, computed at rates not less than wage rates bound herein pertaining to type of Work being performed. When Work is of such a nature that both Building and Highway-Heavy wage scales are incorporated into contract, Contractor shall pay wage rates to mechanics or laborers performing Work in more than one classification at the rate indicated for each classification for time actually worked as determined by area practice applicable to type (Site Construction Crafts or Building Construction Crafts) of Work being performed without regards to skill. Salaried specialists (project superintendent and administrative personnel only) in the permanent employment of Contractor do not fall under any Wage Classification. Wage rates shall be posted by Contractor at site(s) of Work in prominent, easily accessible places where they can be seen by all workers.

C. Overtime Requirements

No Contractor, Subcontractor, or Sub-subcontractor contracting for any part of contract Work which may require or involve the employment of laborers or mechanics shall require or permit any laborer or mechanic in any workweek in which he is employed on such Work, to work in excess of forty hours in such workweek unless such laborer or mechanic receives compensation at a rate not less than one and one-half time his basic rate of pay for all hours in excess of forty hours in such workweek.

2. APPRENTICES

A. Locally and Federally Funded Projects

Apprentices and Trainees will be permitted to work as such only when they are registered, individually, under a bonafide Apprenticeship or Trainee program registered with the Bureau of Apprenticeship and Training, United States Department of Labor. The allowable ration of Apprentices or Trainees to journeyman in any craft classification shall not be greater than the ration permitted to Contractor as stated in the registered apprenticeship program standards. Any employee listed on a payroll at an Apprentice or Trainee wage rate, who is not registered as above, shall be paid the wage rate provided in Contract for Work employee actually performed. Contractor, Subcontractor, or Sub-subcontractor shall furnish to Owner written evidence of registration of his program for Apprentices and Trainees as well as of the appropriate ratios and wage rates, for the area of construction prior to using any Apprentices or Trainees on this Contract.

3. WITHHOLDING OF PAYMENTS

901

Owner may withhold or cause to be withheld from Contractor as much of the accrued payments as necessary to pay laborers and mechanics employed by Contractor, Subcontractors, or Sub-subcontractors the amount of wages required to comply with the Contract. In the event of nonpayment of wages to laborers or mechanics working on the site of the Work of this Contract, Owner may, after Written Notice to Contractor, take such action as may be necessary to cause suspension of any further payments or advance of funds to Contractor until such violations have ceased and until restitution has been made. Payments may also be withheld if Contractor fails to maintain weekly payroll reports or fails to provide copies in a timely manner upon request of Owner.

4. PAYROLLS

- A. Contractor shall keep records showing:
 - 1. the name and occupation of each worker employed by the Contractor or subcontractor(s) in the construction of public work; and
 - 2. the actual per diem wages paid to each worker and
 - 3. Employee Certification. Contractor, Subcontractor, and Sub-subcontractor shall identify in writing, the classification agreed to by all laborers and mechanics employed by them in the execution of the Contract, and pay not less than rates specified in the attached Building Construction and Highway Heavy Wage Rate Schedule(s). Contractor shall prepare a completed form for the signature of Employee and a witness shall sign the form in the presence of Employee. If work performed by worker is different than the trade classification agreed upon, the worker shall be paid for that work no less than the minimum prevailing for that specified trade.
- B. The record shall be open at all reasonable hours to inspection by the officers and agents of the Owner as requested. Contractor will be responsible to provide copies of record as requested by the Owner within two (2) working days. Payrolls relating to this Work shall be maintained during term of Contract and preserved for a period of three (3) years thereafter by Contractor for all laborers and mechanics working on the Work.
- C. A Statement of Compliance, a letter signed and dated by party responsible for supervising the payment of persons employed by Contractor or subcontractor shall accompany payrolls required by Owner. The Statement of Compliance letter shall identify but is not limited to:
 - 1. name of signatory party and title,
 - 2. name of project, payroll period and
 - 3. name of Contractor or Subcontractor.

The signed letter attests that the payroll complies with 29CFR issued by the Secretary of Labor.

5. COMPLAINTS AND PENALTIES

A public body awarding a contract, and an agent or officer of the public body, shall, take cognizance of complaints of all violations of Chapter 2258 Texas Government Code Title 10 or applicable Federal Statutes committed in the execution of the contract; and withhold money forfeited or required to be withheld under this chapter from the payments to the Contractor under the contract. A Contractor or subcontractor(s) who violates this section shall pay to the political subdivision on whose behalf the contract is made, \$60 for each worker employed for each calendar day or part of the day that the worker is paid less than the wage rates stipulated in the contract. A public body shall use any money collected under this section to offset the costs incurred in the administration of this chapter.

Confirmed Disciplinary action taken by Contractor against employees who provide information during an interview or investigation by the Owner on wages received, may result in suspension or debarment from consideration of award of City contracts.

6. AREA PRACTICE

- A. Highway Heavy Construction Rates shall be used on this Project, unless the Project consists primarily of Building Construction and Building Construction Rates are to be used.
1. Building Construction consists generally of all aspects of construction of buildings, which are sheltered enclosures with walk-in access for the purpose of housing persons, machinery, equipment or supplies, including without limitation the installation of utilities and equipment, both above and below grade level, as well as incidental demolition, grading, utilities, paving and other site work. Buildings need not be "habitable" to be classified as Building Construction and the installation of heavy machinery and/or equipment will not generally change a Building Construction project's classification.
 2. The determination of Building Construction Wage Rates includes all construction trades and work necessary to complete a building, regardless of the number of contracts involved, so long as all such contracts are closely related in purpose, time and place.
- B. For projects that involve both Building Construction and Highway Heavy trades, the following classifications shall be used:
1. A multiple classification shall be used if Building Construction items are more than 20% of Highway Heavy project cost.
 2. A multiple classification shall be used if Highway Heavy Construction items are more than 20% of the Building Construction project cost.
 3. When multiple classifications are used, the Highway Heavy Construction Rates are to be paid to workers engaged in site work determined to be five (5) feet beyond the building, extending to the property boundary or construction limits.

7. TEXAS OPEN RECORDS ACT

Unless covered by an exception to mandatory disclosure under the Texas Open Records Act, any and all documents submitted to the Owner become Public Records and are, therefore, subject to public disclosure.

Refer to General Decisions TX20190007 for Prevailing Wage Rate Determination for governing rates on this Project.

1. Additional Trade Information:

Unlisted classifications needed for work not included within the scope of the classifications listed may be added upon the advance approval of the Engineer. Contractor shall submit to the Engineer the following: classification, a bona fide definition of work to be performed and a proposed wage with sample payrolls conforming to area practice prior to the start of the job for that type of work. Proposed trade may not be performed by any trade already listed.

2. Wages:

For overtime, the basic hourly rate listed in the contract wage determination must be used in computing pay obligations.

3. Proper Designation of Trade:

A work classification from the Prevailing Wage Poster for each worker must be made based on the actually type of work he/she performed on the job. In summary the work performed, not the "title" determines the correct worker classification and wage. Each worker must be paid no less than the wage rate on the wage decision for that classification regardless of his/her level of skill (exclusive of a bona fide apprentice currently registered in a DOL approved apprentice program – proof of individual registration must be supplied in advance to the Engineer).

4. Split Classification:

If a firm has employees that perform work in more than one classification, it can pay the wage rates specified for each classification only if it maintains accurate time records showing the amount of time spent in each classification. If accurate time records are not maintained, these

- employees must be paid the highest wage rate of all the classifications of work performed by each worker. Accurate time records tracking how many hours a worker performed the work of one trade and the switched to another trade must be accounted for on a daily basis and reflected on Employer Certified Payroll accordingly.

END OF SECTION



ADDENDUM NO.

OWNER

PROJECT NAME

PROJECT NO.:

DATE OF ADDENDUM:

BID OPENING DATE:

This Addendum forms a part of Contract and clarifies, corrects or modifies original Bid Documents, dated _____, Acknowledge receipt of this addendum in space provided on Bid Form. Failure to do so may subject bidder to disqualification.

- 1)
- 2)
- 3)

Approved by:

Engineer

NON-COLLUSION AFFIDAVIT

STATE OF TEXAS §
 §
COUNTY OF §

By the signature below, the signatory for the bidder certifies that neither he nor the firm, corporation, partnership or institution represented by the signatory or anyone acting for the firm bidding this project has violated the antitrust laws of this State, codified at Section 15.01, et seq., Texas Business and Commerce Code, or the Federal antitrust laws, nor communicated directly or indirectly the bid made to any competitor or any other person engaged in the same line of business, nor has the signatory or anyone acting for the firm, corporation or institution submitting a bid committed any other act of collusion related to the development and submission of this bid proposal.

Signature: [Handwritten Signature]
Printed Name: Kyle Lewis
Title: Vice President
Company: Angel Brothers Enterprises, Ltd.
Date: 12/16/17

SUBSCRIBED and sworn to before me the undersigned authority by Kyle Lewis the Vice President of Angel Brothers Enterprises, Ltd. on behalf of said bidder.

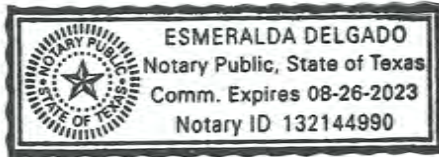

[Handwritten Signature]
Notary Public in and for the
State of Texas

My commission expires: 08/26/2023

[Handwritten Initials]

SAMPLE FORMS

94

Work Change Directive

No. _____

Date of Issuance: _____ Effective Date: _____

Project:	Owner:	Owner's Contract No.:
Contract:	Date of Contract:	
Contractor:	Engineer's Project No.:	

You are directed to proceed promptly with the following change(s):

Item No.	Description

Attachments (list documents supporting change):

Purpose for Work Change Directive:

- Authorization for Work described herein to proceed on the basis of Cost of the Work due to:
 - Nonagreement on pricing of proposed change.
 - Necessity to expedite Work described herein prior to agreeing to changes on Contract Price and Contract Time.

Estimated change in Contract Price and Contract Times:

Contract Price \$ _____ (increase/decrease) Contract Time _____ days (increase/decrease)

If the change involves an increase, the estimated amounts are not to be exceeded without further authorization.

Recommended for Approval by Engineer:	Date:
Authorized for Owner by:	Date:
Accepted for Contractor by:	Date:
Approved by Funding Agency (if applicable):	Date:

9d

Change Order

No. _____

Date of Issuance: _____ Effective Date: _____

Project:	Owner:	Owner's Contract No.:
Contract:		Date of Contract:
Contractor:		Engineer's Project No.:

The Contract Documents are modified as follows upon execution of this Change Order:

Description: _____

Attachments: (List documents supporting change): _____

CHANGE IN CONTRACT PRICE:

CHANGE IN CONTRACT TIMES:

Original Contract Price:	Original Contract Times: <input type="checkbox"/> Working days <input type="checkbox"/> Calendar days
\$ _____	Substantial completion (days or date): _____
	Ready for final payment (days or date): _____

[Increase] [Decrease] from previously approved Change Orders No. _____ to No. _____:	[Increase] [Decrease] from previously approved Change Orders No. _____ to No. _____:
\$ _____	Substantial completion (days): _____
	Ready for final payment (days): _____

Contract Price prior to this Change Order:	Contract Times prior to this Change Order:
\$ _____	Substantial completion (days or date): _____
	Ready for final payment (days or date): _____

[Increase] [Decrease] of this Change Order:	[Increase] [Decrease] of this Change Order:
\$ _____	Substantial completion (days or date): _____
	Ready for final payment (days or date): _____

Contract Price incorporating this Change Order:	Contract Times with all approved Change Orders:
\$ _____	Substantial completion (days or date): _____
	Ready for final payment (days or date): _____

RECOMMENDED:	ACCEPTED:	ACCEPTED:
By: _____ Engineer (Authorized Signature)	By: _____ Owner (Authorized Signature)	By: _____ Contractor (Authorized Signature)

Date: _____ Date: _____ Date: _____

Approved by Funding Agency (if applicable): _____ Date: _____

9/1

A. GENERAL INFORMATION

This document was developed to provide a uniform format for handling contract changes that affect Contract Price or Contract Times. Changes that have been initiated by a Work Change Directive must be incorporated into a subsequent Change Order if they affect Price or Times.

Changes that affect Contract Price or Contract Times should be promptly covered by a Change Order. The practice of accumulating Change Orders to reduce the administrative burden may lead to unnecessary disputes.

If Milestones have been listed in the Agreement, any effect of a Change Order thereon should be addressed.

For supplemental instructions and minor changes not involving a change in the Contract Price or Contract Times, a Field Order should be used.

B. COMPLETING THE CHANGE ORDER FORM

Engineer normally initiates the form, including a description of the changes involved and attachments based upon documents and proposals submitted by Contractor, or requests from Owner, or both.

Once Engineer has completed and signed the form, all copies should be sent to Owner or Contractor for approval, depending on whether the Change Order is a true order to the Contractor or the formalization of a negotiated agreement for a previously performed change. After approval by one contracting party, all copies should be sent to the other party for approval. Engineer should make distribution of executed copies after approval by both parties.

If a change only applies to price or to times, cross out the part of the tabulation that does not apply.

10

Progress Estimate

Contractor's Application

For (contract):		Application Number:								
Application Period:		Application Date:								
A		B	C	D	E	F	G			
Bid Item No.	Description	Bid Quantity	Unit Price	Bid Value	Estimated Quantity Installed	Value	Materials Presently Stored (not in C)	Total Completed and Stored to Date (D + E)	% (F) B	Balance to Finish (B - F)
Totals										

41

Stored Material Summary

Contractor's Application

For (contract):		Application Number:						
Application Period:		Application Date:						
A Invoice No.	B Shop Drawing Transmittal No.	C Materials Description	D Stored Previously		E Stored this Month		G Materials Remaining in Storage (\$) (D + E - F)	
			Date (Month/Year)	Amount (\$)	Date (Month/Year)	Amount (\$)		F Incorporated in Work Date (Month/Year)
		Totals						

Certificate of Substantial Completion

Project:	Owner:	Owner's Contract No.:
Contract:		Date of Contract:
Contractor:		Engineer's Project No.:

This [tentative] [definitive] Certificate of Substantial Completion applies to:

- All Work under the Contract Documents:
 The following specified portions:

_____ Date of Substantial Completion

The Work to which this Certificate applies has been inspected by authorized representatives of Owner, Contractor and Engineer, and found to be substantially complete. The Date of Substantial Completion of the Project or portion thereof designated above is hereby declared and is also the date of commencement of applicable warranties required by the Contract Documents, except as stated below.

A [tentative] [revised tentative] [definitive] list of items to be completed or corrected, is attached hereto. This list may not be all-inclusive, and the failure to include any items on such list does not alter the responsibility of the Contractor to complete all Work in accordance with the Contract Documents.

The responsibilities between OWNER and CONTRACTOR for security, operation, safety, maintenance, heat, utilities, insurance and warranties shall be as provided in the Contract Documents except as amended as follows:

- Amended Responsibilities
 Not Amended

Owner's Amended Responsibilities:

Contractor's Amended Responsibilities:

The following documents are attached to and made part of this Certificate:

This Certificate does not constitute an acceptance of Work not in accordance with the Contract Documents nor is it a release of Contractor's obligation to complete the Work in accordance with the Contract Documents.

Executed by Engineer Date

Accepted by Contractor Date

Accepted by Owner Date

Jal

**WALKER PARTNERS
TECHNICAL SPECIFICATIONS**

DIVISION 1 – GENERAL REQUIREMENTS

TABLE OF CONTENTS

Section Title

DIVISION 1 – GENERAL REQUIREMENTS

01 10 00	Summary
01 20 00	Price and Payment Procedures
01 21 00	Mobilization, Traffic Handling, and Incidentals
01 30 00	Administrative Requirements
01 33 00	Submittal Procedures
01 40 00	Quality Requirements
01 50 00	Temporary Facilities and Controls
01 60 00	Product Requirements
01 70 00	Execution and Closeout Requirements

END OF SECTION



SECTION 01 10 00 - SUMMARY

PART 1 GENERAL

1.1 SUMMARY

A. Section Includes:

1. Contract description.
2. Work by Owner or other Work at the Site.
3. Owner-furnished products.
4. Contractor's use of Site and premises.
5. Future work.
6. Work sequence.
7. Owner occupancy.
8. Permits.
9. Specification conventions.
10. Reference specifications and standards.

1.2 CONTRACT DESCRIPTION

A. Work of the Project includes construction of streets pavement maintenance and streets pavement preventative maintenance.

B. Construct the Work in accordance with the Bid Items listed on the Bid Form and as generally described below:

1. Mobilization/Demobilization.
2. Flexible Pavement Repair
3. Joint and Crack Sealing
4. Chip Seal
5. Fog Seal
6. Scrub Seal
7. Frictional Asphaltic Surface Preservation Treatment
8. All other Work.
 - a. Install all other project Work as presented in the Project Manual.

1.3 WORK BY OWNER OR OTHERS

A. If Owner-awarded contracts interfere with each other due to work being performed at the same time or at the same Site, Owner will determine the sequence of work under all contracts according to "Work Sequence" and "Contractor's Use of Site and Premises" Articles in this Section.

B. Coordinate Work with utilities of Owner and public or private agencies.

1.4 OWNER-FURNISHED PRODUCTS

A. Owner's Responsibilities:

1. Arrange for and deliver Owner-reviewed Shop Drawings, Product Data, and Samples to Contractor.

2. Upon delivery, inspect products jointly with Contractor.
3. Submit claims for transportation damage and replace damaged, defective, or deficient items.
4. Arrange for manufacturers' warranties, inspections, and service.

B. Contractor's Responsibilities:

1. Review Owner-reviewed Shop Drawings, Product Data, and Samples.
2. Receive and unload products at Site; inspect for completeness or damage jointly with Owner.
3. Handle, store, install, and finish products.
4. Repair or replace items damaged after receipt.

1.5 CONTRACTOR'S USE OF SITE AND PREMISES

A. Limit use of Site and premises to allow:

1. Owner occupancy.
2. Use of Site by the public.

B. Construction Operations: **Limited to areas indicated on Drawings.**

1. Noisy and Disruptive Operations (such as Use of Jack Hammers and Other Noisy Equipment): Not allowed in close proximity to existing building during regular hours of operation. Coordinate and schedule such operations with Owner to minimize disruptions.

C. Time Restrictions for Performing Work: as shown in Special Provision 5.

D. Construction Plan: Before start of construction, submit a construction plan regarding access to Work and use of Site for acceptance by Owner. After acceptance of plan, construction operations shall comply with accepted plan unless deviations are accepted by Owner in writing.

1.6 WORK SEQUENCE

A. Sequencing of Construction Plan shall be in accordance with Special Provision 5 and Sheet C003. Before start of construction, submit one copy of construction plan regarding phasing of construction and new Work for acceptance by Owner. After acceptance of plan, construction sequencing shall comply with accepted plan unless deviations are accepted by Owner in writing.

B. Contractor shall update the construction sequencing plan and schedule monthly to reflect progress of the work. Updated schedules shall be submitted to the Engineer for approval. Monthly partial payments will be dependent upon submission of an updated construction schedule satisfactory to the Engineer.

1.7 PROGRESS REPORTING

A. Monthly progress meetings shall be held on dates mutually agreeable to Engineer, Owner and Contractor. These meetings may be held at Site or Owner's facilities as determined by Engineer. Items to be discussed at this meeting include progress of work, upcoming work items, status of submittals, monthly pay estimates, etc.

1.8 OWNER OCCUPANCY

- A. Cooperate with Owner to minimize conflict and to facilitate Owner's operations.
- B. Schedule the Work to accommodate Owner use of facility.

1.9 PERMITS

- A. Furnish all necessary permits for construction of Work including the following:
 - 1. TxDOT.

1.10 SPECIFICATION CONVENTIONS

- A. These Specifications are written in imperative mood and streamlined form. This imperative language is directed to Contractor unless specifically noted otherwise. The words "shall be" are included by inference where a colon (:) is used within sentences or phrases.

PART 2 PRODUCTS - Not Used

PART 3 EXECUTION - Not Used

END OF SECTION

SECTION 01 20 00 - PRICE AND PAYMENT PROCEDURES

PART 1 GENERAL

1.1 SECTION INCLUDES

- A. Contingency allowances.
- B. Testing and inspection allowances.
- C. Application for Payment.
- D. Change procedures.
- E. Defect assessment.
- F. Unit prices.
- G. Alternates.

1.2 CONTINGENCY ALLOWANCES

- A. Include in Contract a stipulated sum/price of \$45,000.00 for use upon Owner's instruction as a contingency allowance.
- B. Contractor's costs for products, delivery, installation, labor, insurance, payroll, taxes, bonding, equipment rental, overhead, and profit will be included in Change Orders authorizing expenditure of funds from this contingency allowance.
- C. Funds will be drawn from contingency allowance only by Change Order.
- D. At closeout of Contract, funds remaining in contingency allowance will be credited to Owner by Change Order.

1.3 APPLICATION FOR PAYMENT

- A. Submit three copies of each Application for Payment on EJCDC C-620 - Contractor's Application for Payment or a Contractor's electronic media driven form as approved by the Engineer.
- B. Content and Format: Use Schedule of Values for listing items in Application for Payment.
- C. Submit updated construction schedule with each Application for Payment.
- D. Payment Period: Submit at intervals stipulated in the Agreement.
- E. Submit submittals with transmittal letter as specified in Section 01 33 00 - Submittal Procedures.

gbr

- F. Substantiating Data: When Engineer requires substantiating information, submit data justifying dollar amounts in question. Include the following with Application for Payment:
 - 1. Partial release of liens from major Subcontractors and vendors.
 - 2. Record Documents as specified in Section 01 70 00 - Execution and Closeout Requirements, for review by Owner, which will be returned to Contractor.
 - 3. Affidavits attesting to off-Site stored products.
 - 4. Construction Schedule, as described in Special Provision 5 and Detail Sheet C003.

1.4 CHANGE PROCEDURES

- A. Submittals: Submit name of individual who is authorized to receive change documents and is responsible for informing others in Contractor's employ or Subcontractors of changes to the Work.
- B. Carefully study and compare Contract Documents before proceeding with fabrication and installation of Work. Promptly advise Architect/Engineer of any error, inconsistency, omission, or apparent discrepancy.
- C. Engineer will advise of minor changes in the Work not involving adjustment to Contract Sum/Price or Contract Time by issuing supplemental instructions on EJCDC C-942.
- D. Engineer may issue Proposal Request including a detailed description of proposed change with supplementary or revised Drawings and Specifications, a change in Contract Time for executing the change and with the period of time during which the requested price will be considered valid. Contractor will prepare and submit estimate within 10 calendar days.
- E. Contractor may propose changes by submitting a request for change to Engineer, describing proposed change and its full effect on the Work. Include a statement describing reason for the change and the effect on Contract Sum/Price and Contract Time with full documentation and a statement describing effect on the Work by separate or other Contractors. Document requested substitutions according to Section 01 60 00 – Product Requirements.
- F. Stipulated Sum/Price Change Order: Based on Proposal Request and Contractor's fixed price quotation or Contractor's request for Change Order as recommended by Engineer and approved by Owner.
- G. Unit Price Change Order: For Contract unit prices and quantities, the Change Order will be executed on a fixed unit price basis. For unit costs or quantities of units of that which are not predetermined, execute Work under Work Directive Change. Changes in Contract Sum/Price or Contract Time will be computed as specified for Time and Material Change Order.
- H. Work Directive Change: Engineer may issue directive, on EJCDC C-940 - Work Change Directive signed by Owner, instructing Contractor to proceed with change in the Work, for subsequent inclusion in a Change Order. Document will describe changes in the Work and designate method of determining any change in Contract Sum/Price or Contract Time. Promptly execute change.
- I. Document each quotation for change in Project Cost or Time with sufficient data to allow evaluation of quotation.



- J. Change Order Forms: EJCDC C-941 - Change Order or as approved by Engineer.
- K. Execution of Change Orders: Engineer will issue Change Orders for signatures of parties as provided in Conditions of the Contract.
- L. Correlation of Contractor Submittals:
 - 1. Promptly revise Schedule of Values and Application for Payment forms to record each authorized Change Order as separate line item and adjust Contract Sum/Price.
 - 2. Promptly revise Progress Schedules to reflect change in Contract Time, revise subschedules to adjust times for other items of Work affected by the change, and resubmit.
 - 3. Promptly enter changes in Record Documents.

1.5 DEFECT ASSESSMENT

- A. Replace the Work, or portions of the Work, not conforming to specified requirements.
- B. If, in the opinion of Engineer, it is not practical to remove and replace the Work, Engineer will direct appropriate remedy or adjust payment.
- C. The defective Work may remain, but unit sum/price will be adjusted to new sum/price at discretion of Engineer and Owner.
- D. Individual Specification Sections may modify these options or may identify specific formula or percentage sum/price reduction.
- E. Authority of Engineer and Owner to assess defects and identify payment adjustments is final.
- F. Nonpayment for Rejected Products: Payment will not be made for rejected products for any of the following reasons:
 - 1. Products wasted or disposed of in a manner that is not acceptable.
 - 2. Products determined as unacceptable before or after placement.
 - 3. Products not completely unloaded from transporting vehicle.
 - 4. Products placed beyond lines and levels of the required Work.
 - 5. Products remaining on hand after completion of the Work.
 - 6. Loading, hauling, and disposing of rejected products.

1.6 UNIT PRICES

- A. Authority: Measurement methods are delineated in individual Specification Sections.
- B. Measurement methods delineated in individual Specification Sections complement criteria of this Section. In event of conflict, requirements of individual Specification Section govern.
- C. Take measurements and compute quantities. Engineer will verify measurements and quantities.
- D. Unit Quantities: Quantities and measurements indicated on Bid Form are for Contract purposes only. Actual quantities provided shall determine payment.

1. When actual Work requires more or fewer quantities than those quantities indicated, provide required quantities at contracted unit sum/prices.
 2. When actual Work requires 25 percent or greater change in quantity than those quantities indicated, Owner or Contractor may claim a Contract Price adjustment.
- E. Payment Includes: Full compensation for required labor, products, tools, equipment, plant and facilities, transportation, services and incidentals; erection, application, or installation of item of the Work; overhead and profit.
- F. Final payment for Work governed by unit prices will be made on basis of actual measurements and quantities accepted by Architect/Engineer multiplied by unit sum/price for Work incorporated in or made necessary by the Work.
- G. Measurement of Quantities:
1. Measurement by Volume: Measured by cubic dimension using mean length, width, and height or thickness.
 2. Measurement by Area: Measured horizontally by square dimension using mean length and width or radius.
 3. Linear Measurement: Measured horizontally by linear dimension, at item centerline or mean chord.
 4. Stipulated Sum/Price Measurement: Items measured by weight, volume, area, or linear means or combination, as appropriate, as completed item or unit of the Work.

1.7 ALTERNATES

- A. Alternates quoted on Bid Forms will be reviewed and accepted or rejected at Owner's option. Accepted Alternates will be identified in Owner-Contractor Agreement.

1.8 MOBILIZATION, TRAFFIC HANDLING, AND INCIDENTALS

- A. As specified in Section 01 21 00.

PART 2 PRODUCTS - Not Used

PART 3 EXECUTION - Not Used

END OF SECTION

SECTION 01 21 00 – MOBILIZATION, TRAFFIC HANDLING, AND INCIDENTALS

PART 1 GENERAL

1.1 SUMMARY

A. Section Includes:

1. Project Mobilization and Demobilization.
2. Traffic Handling.
3. All project costs (incidentals) not included in the contract bid items.

1.2 UNIT PRICE - MEASUREMENT AND PAYMENT

A. Basis of Measurement: By the Lump Sum as the work progresses.

B. Basis of Payment: This item will be paid for at the contract unit price bid for "Mobilization, Traffic Handling, and Project Incidentals," which price shall be full compensation for mobilization and demobilization of all contractor personnel, facilities, equipment, and supplies, for all equipment, labor, and material associated with traffic handling, and all other project costs not specifically covered in the contract bid items.

C. Partial payments for this item will be administered as follows. The adjusted contract amount for construction items as used below is defined as the total contract amount less the lump sum bid for mobilization.

1. When 1% of the adjusted contract amount for construction items is earned, 50% of the mobilization lump sum bid will be paid.
2. When 5% of the adjusted contract amount for construction items is earned, 75% of the mobilization lump sum bid will be paid.
3. When 10% of the adjusted contract amount for construction items is earned, 90% of the mobilization lump sum bid will be paid.
4. Upon completion of all work items, payment for the remainder of the mobilization lump sum bid will be made.

D. The lump sum bid for mobilization shall not exceed 10% of the total contract.

1.3 REFERENCES – Not used.

1.4 QUALITY ASSURANCE – Not used.

PART 2 PRODUCTS – Not used.

PART 3 EXECUTION – Not used.

END OF SECTION

Qob

SECTION 01 30 00 - ADMINISTRATIVE REQUIREMENTS

PART 1 GENERAL

1.1 SECTION INCLUDES

- A. Coordination and Project conditions.
- B. Preconstruction meeting.
- C. Site mobilization meeting.
- D. Progress meetings.
- E. Preinstallation meetings.
- F. Closeout meeting.
- G. Alteration procedures.

1.2 COORDINATION AND PROJECT CONDITIONS

- A. Coordinate scheduling, submittals, and Work of various Sections of Project Manual to ensure efficient and orderly sequence of installation of interdependent construction elements, with provisions for accommodating items installed later.
- B. Verify that utility requirements and characteristics of operating equipment are compatible with building utilities. Coordinate Work of various Sections having interdependent responsibilities for installing, connecting to, and placing operating equipment in service.
- C. Coordinate space requirements, supports, and installation of mechanical and electrical Work indicated diagrammatically on Drawings. Follow routing shown for pipes, ducts, and conduit as closely as practical; place runs parallel with lines of building. Use spaces efficiently to maximize accessibility for other installations, for maintenance, and for repairs.
- D. Coordinate interruptions of all utilities and services. All work shall be in accordance with the requirements of the applicable utility company or agency involved.
- E. In finished areas except as otherwise indicated, conceal pipes, ducts, and wiring within construction. Coordinate locations of fixtures and outlets with finish elements.
- F. Coordinate completion and clean-up of Work of separate Sections in preparation for Substantial Completion and for portions of Work designated for Owner's partial occupancy.
- G. After Owner's occupancy of premises, coordinate access to Site for correction of defective Work and Work not complying with Contract Documents, to minimize disruption of Owner's activities.

gbr

1.3 PRECONSTRUCTION MEETING

- A. Engineer will schedule and preside over meeting after the Agreement has been executed and all bonds and insurance are in affect for the project.
- B. Attendance Required: Engineer, Owner, Inspector, and Contractor.
- C. Minimum Agenda:
 - 1. Execution of Owner-Contractor Agreement.
 - 2. Submission of executed bonds and insurance certificates.
 - 3. Distribution of Contract Documents.
 - 4. Submission of list of Subcontractors, list of products, schedule of values, and Progress Schedule.
 - 5. Security and housekeeping procedures.
 - 6. Application for payment procedures.
 - 7. Designation of personnel representing parties in Contract and Engineer.
 - 8. Procedures and processing of requests for interpretations, field decisions, submittals, substitutions, Applications for Payments, proposal request, Change Orders, and Contract closeout procedures.
 - 9. Scheduling.
 - 10. Scheduling activities of Contractor. Procedures of testing.
 - 11. Procedures for maintaining record documents.
 - 12. Inspection and acceptance of work during construction period.

1.4 PROGRESS MEETINGS

- A. Schedule and administer meetings throughout progress of the Work at monthly intervals.
- B. Engineer will make arrangements for meetings, prepare agenda with copies for participants, and preside over meetings.
- C. Attendance Required: Job superintendent, major Subcontractors and suppliers, and Engineer, as appropriate to agenda topics for each meeting.
- D. Minimum Agenda:
 - 1. Review minutes of previous meetings.
 - 2. Review of Work progress.
 - 3. Field observations, problems, and decisions.
 - 4. Identification of problems impeding planned progress.
 - 5. Review of submittal schedule and status of submittals.
 - 6. Maintenance of Progress Schedule.
 - 7. Corrective measures to regain projected schedules.
 - 8. Planned progress during succeeding work period.
 - 9. Coordination of projected progress.
 - 10. Maintenance of quality and work standards.
 - 11. Effect of proposed changes on Progress Schedule and coordination.
 - 12. Other business relating to Work.

25

1.5 PREINSTALLATION MEETINGS

- A. When required in individual Specification Sections, convene preinstallation meetings at Project Site before starting Work of specific Section.
- B. Require attendance of parties directly affecting, or affected by, Work of specific Section.
- C. Notify Engineer four days in advance of meeting date.
- D. Prepare agenda and preside over meeting:
 - 1. Review conditions of installation, preparation, and installation procedures.
 - 2. Review coordination with related Work.

1.6 CLOSEOUT MEETING

- A. Schedule Project closeout meeting with sufficient time to prepare for requesting Substantial Completion. Preside over meeting and be responsible for minutes.
- B. Attendance Required: Contractor, Engineer, Owner, and others appropriate to agenda.
- C. Notify Engineer ten days in advance of meeting date.
- D. Minimum Agenda:
 - 1. Contractor's inspection of Work.
 - 2. Contractor's preparation of an initial "punch list."
 - 3. Procedure to request Engineer inspection to determine date of Substantial Completion.
 - 4. Completion time for correcting deficiencies.
 - 5. Inspections by authorities having jurisdiction.
 - 6. Certificate of Occupancy and transfer of insurance responsibilities.
 - 7. Partial release of retainage.
 - 8. Final cleaning.
 - 9. Preparation for final inspection.
 - 10. Closeout Submittals:
 - a. Project record documents.
 - b. Operating and maintenance documents.
 - c. Operating and maintenance materials.
 - d. Affidavits.
 - 11. Final Application for Payment.
 - 12. Contractor's demobilization of Site.

PART 2 PRODUCTS - Not Used

PART 3 EXECUTION

3.1 ALTERATION PROCEDURES

- A. Designated areas of existing facilities will be occupied for normal operations during progress of construction. Cooperate with Owner in scheduling operations to minimize conflict and to permit continuous usage.

9/26

1. Perform Work not to interfere with operations of occupied areas.
 2. Keep utility and service outages to a minimum and perform only after written approval of Owner.
 3. Clean Owner-occupied areas daily. Clean spillage, overspray, and heavy collection of dust in Owner-occupied areas immediately.
- B. Materials: As specified in product Sections; match existing products with new products for patching and extending Work.
- C. Employ original and/or skilled and experienced installer to perform alteration and renovation Work.
- D. Cut, move, or remove items as necessary for access to alterations and renovation Work. Replace and restore at completion. Comply with Section 01 70 00 - Execution and Closeout Requirements
- E. Remove unsuitable material not marked for salvage, including rotted wood, corroded metals, and deteriorated masonry and concrete. Replace materials as specified for finished Work.
- F. Remove debris and abandoned items from area and from concealed spaces.
- G. Prepare surface and remove surface finishes to permit installation of new Work and finishes.
- H. Close openings in exterior surfaces to protect existing Work from weather and extremes of temperature and humidity.
- I. Remove, cut, and patch Work to minimize damage and to permit restoring products and finishes to original or specified condition.
- J. Refinish existing visible surfaces to remain in renovated rooms and spaces, to specified condition for each material, with neat transition to adjacent finishes.
- K. Where new Work abuts or aligns with existing Work, provide smooth and even transition. Patch Work to match existing adjacent Work in texture and appearance.
- L. When finished surfaces are cut so that smooth transition with new Work is not possible, terminate existing surface along straight line at natural line of division and submit recommendation to Engineer for review.
- M. Where change of plane of 1/4 inch or more occurs, submit recommendation for providing smooth transition to Engineer for review.
- N. Patch or replace portions of existing surfaces that are damaged, lifted, discolored, or showing other imperfections.
- O. Finish surfaces as specified in individual product Sections.

END OF SECTION

SECTION 01 33 00 - SUBMITTAL PROCEDURES

PART 1 GENERAL

1.1 SECTION INCLUDES

- A. Submittal procedures.
- B. Construction progress schedules.
- C. Proposed product list.
- D. Product data.
- E. Samples.
- F. Design data.
- G. Test reports.
- H. Certificates.
- I. Manufacturer's instructions.
- J. Manufacturer's field reports.
- K. Contractor review.
- L. Engineer review.

1.2 SUBMITTAL PROCEDURES

- A. Submittals shall be directly from the Contractor. Submittals from others (i.e., suppliers or subcontractors) shall not be accepted.
- B. Transmit each submittal on an Engineer accepted form.
- C. Sequentially number transmittal forms. Mark revised submittals with original number and sequential alphabetic suffix.
- D. Identify Project, Contractor, subcontractor and supplier; pertinent drawing and detail number, and specification section number, appropriate to submittal.
- E. Apply Contractor's stamp, signed or initialed certifying that review, approval, verification of products required, field dimensions, adjacent construction Work, and coordination of information is in accordance with requirements of the Work and Contract Documents.
- F. Schedule submittals to expedite Project, and deliver to Engineer at business address. Coordinate submission of related items.
- G. For each submittal for review, allow 15 days excluding delivery time to and from Contractor.
- H. Identify variations from Contract Documents and product or system limitations which may be detrimental to successful performance of completed Work.
- I. Allow space on submittals for Contractor and Engineer review stamps.
- J. When revised for resubmission, identify changes made since previous submission.
- K. Distribute copies of reviewed submittals as appropriate. Instruct parties to promptly report inability to comply with requirements.

9/5

- L. Submittals not requested will not be recognized or processed.
- M. Incomplete Submittals: Engineer will not review. Complete submittals for each item are required. Delays resulting from incomplete submittals are not the responsibility of Engineer.

1.3 CONSTRUCTION PROGRESS SCHEDULES

- A. Comply with Construction Schedule, as described in Special Provisions 5 and Detail Sheet C003.

1.4 PROPOSED PRODUCT LIST

- A. Within 15 days after date of Notice to Proceed, submit list of major products proposed for use, with name of manufacturer, trade name, and model number of each product.
- B. For products specified only by reference standards, indicate manufacturer, trade name, model or catalog designation, and reference standards.

1.5 PRODUCT DATA

- A. Product Data: Action Submittal: Submit to Engineer for review for assessing conformance with information given and design concept expressed in Contract Documents.
- B. Submit electronic submittals via email as PDF electronic files.
- C. Mark each copy to identify applicable products, models, options, and other data. Supplement manufacturers' standard data to provide information specific to this Project.
- D. Indicate product utility and electrical characteristics, utility connection requirements, and location of utility outlets for service for functional equipment and appliances.
- E. After review, produce copies and distribute according to "Submittal Procedures" Article and for record documents described in Section 01 70 00 - Execution and Closeout Requirements.

1.6 ELECTRONIC CAD FILES OF PROJECT DRAWINGS

- A. Electronic CAD Files of Project Drawings: May only be used to expedite production of Shop Drawings for the Project. Use for other Projects or purposes is not allowed.
- B. Electronic CAD Files of Project Drawings: Distributed only under the following conditions:
 - 1. Use of files is solely at receiver's risk. Engineer does not warrant accuracy of files. Receiving files in electronic form does not relieve receiver of responsibilities for measurements, dimensions, and quantities set forth in Contract Documents. In the event of ambiguity, discrepancy, or conflict between information on electronic media and that in Contract Documents, notify Engineer of discrepancy and use information in hard-copy Drawings and Specifications.
 - 2. CAD files do not necessarily represent the latest Contract Documents, existing conditions, and as-built conditions. Receiver is responsible for determining and complying with these conditions and for incorporating addenda and modifications.

3. User is responsible for removing information not normally provided on Shop Drawings and removing references to Contract Documents. Shop Drawings submitted with information associated with other trades or with references to Contract Documents will not be reviewed and will be immediately returned.
4. Receiver shall not hold Engineer responsible for data or file clean-up required to make files usable, nor for error or malfunction in translation, interpretation, or use of this electronic information.
5. Receiver shall understand that even though Engineer has computer virus scanning software to detect presence of computer viruses, there is no guarantee that computer viruses are not present in files or in electronic media.
6. Receiver shall not hold Engineer responsible for such viruses or their consequences, and shall hold Engineer harmless against costs, losses, or damage caused by presence of computer virus in files or media.

1.7 SHOP DRAWINGS

- A. Shop Drawings: Action Submittal: Submit to Engineer for assessing conformance with information given and design concept expressed in Contract Documents.
- B. Indicate special utility and electrical characteristics, utility connection requirements, and location of utility outlets for service for functional equipment and appliances.
- C. When required by individual Specification Sections, provide Shop Drawings signed and sealed by a professional Engineer responsible for designing components shown on Shop Drawings.
 1. Include signed and sealed calculations to support design.
 2. Submit Shop Drawings and calculations in form suitable for submission to and approval by authorities having jurisdiction.
 3. Make revisions and provide additional information when required by authorities having jurisdiction.
- D. Submit number of opaque reproductions Contractor requires, plus two copies Engineer will retain.
- E. After review, produce copies and distribute according to "Submittal Procedures" Article and for record documents described in Section 01 70 00 - Execution and Closeout Requirements.

1.8 SAMPLES

- A. Samples: Action Submittal: Submit to Engineer for assessing conformance with information given and design concept expressed in Contract Documents.
- B. Samples for Selection as Specified in Product Sections:
 1. Submit to Engineer for aesthetic, color, and finish selection.
 2. Submit Samples of finishes, textures, and patterns for Engineer selection.
- C. Submit Samples to illustrate functional and aesthetic characteristics of products, with integral parts and attachment devices. Coordinate Sample submittals for interfacing work.
- D. Include identification on each Sample, with full Project information.

- E. Submit number of Samples specified in individual Specification Sections; Engineer will retain one Sample.
- F. Reviewed Samples that may be used in the Work are indicated in individual Specification Sections.
- G. Samples will not be used for testing purposes unless specifically stated in Specification Section.
- H. After review, produce copies and distribute according to "Submittal Procedures" Article and for record documents described in Section 01 70 00 - Execution and Closeout Requirements.

1.9 TEST REPORTS

- A. Submit test reports to the Engineer for assessing conformance and compliance to the Contract Documents.

1.10 DESIGN DATA

- A. Submit for Engineer's knowledge as contract administrator or for Owner.
- B. Submit for information for limited purpose of assessing conformance with information given and design concept expressed in Contract Documents.

1.11 TEST REPORTS

- A. Informational Submittal: Submit reports for Engineer's knowledge as Contract administrator or for Owner.
- B. Submit test reports for information for assessing conformance with information given and design concept expressed in Contract Documents.

1.12 CERTIFICATES

- A. Informational Submittal: When specified in Technical Specifications, submit certification by manufacturer, installation/application Subcontractor, or Contractor to Engineer, in quantities specified for Product Data.
- B. Indicate material or product conforms to or exceeds specified requirements. Submit supporting reference data, affidavits, and certifications as appropriate.
- C. Certificates may be recent or previous test results on material or product but must be acceptable to Engineer.

1.13 MANUFACTURER'S INSTRUCTIONS

- A. Informational Submittal: When specified in Technical Specifications, submit manufacturer's installation instructions for Engineer's knowledge as Contract administrator or for Owner.

- B. Submit printed instructions for delivery, storage, assembly, installation, startup, adjusting, and finishing, to Engineer for delivery to Owner in quantities specified for Product Data.
- C. Indicate special procedures, perimeter conditions requiring special attention, and special environmental criteria required for application or installation.

1.14 MANUFACTURER'S FIELD REPORTS

- A. Informational Submittal: Submit reports for Engineer's knowledge as Contract administrator or for Owner.
- B. Submit report in duplicate within three days of observation to Engineer for information.
- C. Submit reports for information for limited purposes of assessing conformance with information given and design concept expressed in Contract Documents.

1.15 CONTRACTOR REVIEW

- A. Review for compliance with Contract Documents and approve submittals before transmitting to Engineer.
- B. Contractor: Responsible for:
 - 1. Determination and verification of materials including manufacturer's catalog numbers.
 - 2. Determination and verification of field measurements and field construction criteria.
 - 3. Checking and coordinating information in submittal with requirements of Work and of Contract Documents.
 - 4. Determination of accuracy and completeness of dimensions and quantities.
 - 5. Confirmation and coordination of dimensions and field conditions at Site.
 - 6. Construction means, techniques, sequences, and procedures.
 - 7. Safety precautions.
 - 8. Coordination and performance of Work of all trades.
- C. Stamp, sign or initial, and date each submittal to certify compliance with requirements of Contract Documents.
- D. Do not fabricate products or begin Work for which submittals are required until approved submittals have been received from Engineer.

1.16 ENGINEER REVIEW

- A. Do not make "mass submittals" to Engineer. "Mass submittals" are defined as six or more submittals or items in one day or 15 or more submittals or items in one week. If "mass submittals" are received, Engineer's review time stated above will be extended as necessary to perform proper review. Engineer will review "mass submittals" based on priority determined by Engineer after consultation with Owner.
- B. Informational submittals and other similar data are for Engineer's information, do not require Engineer's responsive action, and will not be reviewed or returned with comment.

- C. Submittals made by Contractor that are not required by Contract Documents may be returned without action.
- D. Submittal approval does not authorize changes to Contract requirements unless accompanied by Change Order, Field Order, or Work Change Directive.

PART 2 PRODUCTS - Not Used

PART 3 EXECUTION - Not Used

END OF SECTION

20

SECTION 01 40 00 - QUALITY REQUIREMENTS

PART 1 GENERAL

1.1 SECTION INCLUDES

- A. Quality control.
- B. Tolerances.
- C. References.
- D. Labeling.
- E. Testing and inspection services.
- F. Manufacturers' field services.

1.2 QUALITY CONTROL

- A. Monitor quality control over suppliers, manufacturers, products, services, Site conditions, and workmanship, to produce Work of specified quality.
- B. Comply with manufacturers' instructions, including each step in sequence.
- C. When manufacturers' instructions conflict with Contract Documents, request clarification from Engineer before proceeding.
- D. Products, materials, and equipment may be subject to inspection by Engineer and Owner at place of manufacture or fabrication. Such inspections shall not relieve Contractor of complying with requirements of Contract Documents.
- E. Supervise performance of Work in such manner and by such means to ensure that Work, whether completed or in progress, will not be subjected to harmful, dangerous, damaging, or otherwise deleterious exposure during construction period.

1.3 TOLERANCES

- A. Monitor fabrication and installation tolerance control of products to produce acceptable Work. Do not permit tolerances to accumulate.
- B. Comply with manufacturers' recommended tolerances and tolerance requirements in reference standards. When such tolerances conflict with Contract Documents, request clarification from Engineer before proceeding.
- C. Adjust products to appropriate dimensions; position before securing products in place.

Q&A

1.4 REFERENCES

- A. For products or workmanship specified by association, trade, or other consensus standards, comply with requirements of standard except when more rigid requirements are specified or are required by applicable codes.
- B. Conform to reference standard by date of issue current as of date for receiving Bids except where specific date is established by code.
- C. Obtain copies of standards and maintain on Site when required by product Specification Sections.
- D. When requirements of indicated reference standards conflict with Contract Documents, request clarification from Engineer before proceeding.
- E. Neither contractual relationships, duties, or responsibilities of parties in Contract nor those of Engineer shall be altered from Contract Documents by mention or inference in reference documents.

1.5 LABELING

- A. Attach label from agency approved by authorities having jurisdiction for products, assemblies, and systems required to be labeled by applicable code.
- B. Label Information: Include manufacturer's or fabricator's identification, approved agency identification, and the following information, as applicable, on each label:
 - 1. Model number.
 - 2. Serial number.
 - 3. Performance characteristics.
- C. Manufacturer's Nameplates, Trademarks, Logos, and Other Identifying Marks on Products: Not allowed on surfaces exposed to view in public areas, interior or exterior.

1.6 TESTING AND INSPECTION SERVICES

- A. Owner will employ and pay for specified services of an independent firm to perform testing and inspection.
- B. Independent testing firm will perform tests, inspections, and other services specified in individual Specification Sections and as required by Engineer. In the event of a conflict in the Contract Documents concerning sampling and testing frequency, the more stringent standard shall be enforced, unless otherwise approved by the Engineer.
 - 1. Laboratory: Authorized to operate in State of Texas.
 - 2. Laboratory Staff: Maintain full-time Professional Engineer on staff to review services.
 - 3. Testing Equipment: Calibrated at reasonable intervals with devices of an accuracy traceable to National Bureau of Standards or accepted values of natural physical constants.
- C. Testing, inspections, and source quality control may occur on or off Project Site. Perform off-Site testing as required by Engineer or Owner.

- D. Cooperate with independent testing firm; furnish samples of materials, design mix, equipment, tools, storage, safe access, and assistance by incidental labor as requested.
1. Notify Engineer and independent testing firm 48 hours before expected time for operations requiring services.
 2. Make arrangements with independent testing firm and pay for additional Samples and tests required for Contractor's use.
- E. Testing and employment of testing agency or laboratory shall not relieve Contractor of obligation to perform Work according to requirements of Contract Documents.
- F. Retesting or re-inspection required because of nonconformance with specified or indicated requirements shall be performed by same independent testing firm on instructions from Engineer. Payment for retesting or re-inspection will be charged to Contractor by deducting testing charges from Contract Sum/Price.
- G. Independent Testing Firm Responsibilities:
1. Test Samples of mixes submitted by Contractor.
 2. Provide qualified personnel at Site. Cooperate with Engineer and Contractor in performance of services.
 3. Perform indicated sampling and testing of products according to specified standards.
 4. Ascertain compliance of materials and mixes with requirements of Contract Documents.
 5. Promptly notify Engineer and Contractor of observed irregularities or nonconformance of Work or products.
 6. Perform additional tests required by Engineer.
 7. Attend preconstruction meetings and progress meetings.
- H. Material Testing Reports: After each test, Independent Testing Firm shall promptly submit two copies of testing reports to Engineer, Contractor, and other entities as directed, indicating observations and results of tests and compliance or noncompliance with Contract Documents. At a minimum, include the following information in testing reports:
1. Date issued.
 2. Project title and number.
 3. Name of inspector/testing technician.
 4. Date and time of sampling or inspection.
 5. Identification of product and Specification Section.
 6. Location in Project.
 7. Type of inspection or test.
 8. Date of test.
 9. Results of tests.
 10. Compliance or noncompliance with Contract Documents.
 11. Special observations, if any.
- Submit final report indicating correction of Work previously reported as noncompliant. Log all test results in an electronic spreadsheet for each test procedure and provide updated versions to Engineer at agreed upon time interval.
- I. Limits on Independent Testing Firm:
1. Independent Testing Firm may not release, revoke, alter, or enlarge on requirements of Contract Documents.
 2. Independent Testing Firm may not approve or accept any portion of the Work.

3. Independent Testing Firm may not assume duties of Contractor.
4. Independent Testing Firm has no authority to stop the Work.

1.7 MANUFACTURER'S FIELD SERVICES

- A. When specified in individual Specification Sections, require material or product suppliers or manufacturers to provide qualified staff personnel to observe Site conditions, conditions of surfaces and installation, quality of workmanship, startup of equipment, testing, adjusting, and balancing of equipment as applicable, and to initiate instructions when necessary.
- B. Submit qualifications of observer to Engineer 30 days in advance of required observations. Observer is subject to approval of Engineer.
- C. Report observations and Site decisions or instructions given to applicators or installers that are supplemental or contrary to manufacturer's written instructions.
- D. Refer to Section 01 33 00 - Submittal Procedures, "Manufacturer's Field Reports" Article.

PART 2 PRODUCTS - Not Used

PART 3 EXECUTION - Not Used

END OF SECTION

SECTION 01 50 00 - TEMPORARY FACILITIES AND CONTROLS

PART 1 GENERAL

1.1 SECTION INCLUDES

A. Temporary Utilities:

1. Temporary electricity.
2. Temporary lighting for construction purposes.
3. Temporary ventilation.
4. Temporary water service.
5. Temporary sanitary facilities.

B. Construction Facilities:

1. Field offices and sheds.
2. Vehicular access.
3. Parking.
4. Progress cleaning and waste removal.
5. Project identification.
6. Traffic regulation.
7. Fire-prevention facilities.

C. Temporary Controls:

1. Barriers.
2. Enclosures and fencing.
3. Security.
4. Water control.
5. Dust control.
6. Erosion and sediment control.
7. Noise control.
8. Pest and rodent control.
9. Pollution control.

D. Removal of utilities, facilities, and controls.

1.2 REFERENCES

A. ASTM International:

1. ASTM E 84 - Standard Test Method for Surface Burning Characteristics of Building Materials.
2. ASTM E 90 - Standard Test Method for Laboratory Measurement of Airborne Sound Transmission Loss of Building Partitions and Elements.
3. ASTM E 119 - Standard Test Methods for Fire Tests of Building Construction and Materials.

1.3 TEMPORARY ELECTRICITY

- A. Provide and pay for power service required from utility source as needed for construction operation.

- B. Provide temporary electric feeder from electrical service at location as directed by Engineer. Do not disrupt Owner's use of service.
- C. Complement existing power service capacity and characteristics as required for construction operations.
- D. Provide power outlets with branch wiring and distribution boxes located as required for construction operations. Provide suitable, flexible power cords as required for portable construction tools and equipment.
- E. Provide main service disconnect and overcurrent protection at feeder switch at source distribution equipment.
- F. Permanent convenience receptacles may be used during construction.
- G. Provide distribution equipment, wiring, and outlets for single-phase branch circuits for power and lighting.
 - 1. Provide 20-ampere duplex outlets, single-phase circuits for power.
 - 2. Provide 20-ampere, single-phase branch circuits for lighting.

1.4 TEMPORARY SANITARY FACILITIES

- A. Provide and maintain required facilities and enclosures. Existing facility use is not permitted. Provide facilities at time of Project mobilization.
- B. At end of construction, return existing facilities used for construction operations to same or better condition as original condition.

1.5 VEHICULAR ACCESS

- A. Extend and relocate vehicular access as Work progress requires and provide detours as necessary for unimpeded traffic flow.
- B. Location as approved by Engineer.
- C. Provide unimpeded access for emergency vehicles. Maintain 20 foot-wide driveways with turning space between and around combustible materials.
- D. Provide and maintain access to fire hydrants and control valves free of obstructions.
- E. Provide means of removing mud from vehicle wheels before entering streets.

1.6 PARKING

- A. Location as approved by Engineer.
- B. If Site space is not adequate, provide additional off-Site parking.
- C. Use of existing on-Site streets and driveways used for construction traffic is not permitted. Tracked vehicles are not allowed on paved areas.

28

- D. Use of designated areas of existing parking facilities used by construction personnel is not permitted.
- E. Do not allow heavy vehicles or construction equipment in parking areas.
- F. Do not allow vehicle parking on existing pavement.
- G. Permanent Pavements and Parking Facilities:
 - 1. Before Substantial Completion, bases for permanent roads and parking areas may be used for construction traffic.
 - 2. Avoid traffic loading beyond paving design capacity. Tracked vehicles are not allowed.
 - 3. Use of permanent parking structures is not permitted.
- H. Maintenance:
 - 1. Maintain traffic and parking areas in sound condition free of excavated material, construction equipment, products, mud, snow, ice, and the like.
 - 2. Maintain existing and permanent paved areas used for construction; promptly repair breaks, potholes, low areas, standing water, and other deficiencies, to maintain paving and drainage in original condition.
- I. Removal, Repair:
 - 1. Remove temporary materials and construction before Substantial Completion.
 - 2. Remove underground Work and compacted materials to depth of 2 feet; fill and grade Site as indicated.
 - 3. Repair existing facilities damaged by use, to original condition.
- J. Mud from Site vehicles: Provide means of removing mud from vehicle wheels before entering streets.

1.7 PROGRESS CLEANING AND WASTE REMOVAL

- A. Maintain areas free of waste materials, debris, and rubbish. Maintain Site in clean and orderly condition.
- B. Collect and remove waste materials, debris, and rubbish from Site periodically and dispose of off-Site.
- C. Comply with all applicable local, state, and federal requirements regarding excess and waste material, including methods of handling and disposal.

1.8 PROJECT IDENTIFICATION

- A. Project Identification Sign:
 - 1. Reference Attachment Detail Sheet C002.
- B. Project Informational Signs:
 - 1. Painted informational signs of same colors and lettering as Project identification sign or standard products; size lettering for legibility at 100-foot distance.
 - 2. Provide sign at each field office and storage shed, and provide directional signs to direct traffic into and within Site. Relocate as Work progress requires.

3. No other signs are allowed without Owner's permission except those required by law.
- C. Design sign and structure to withstand 70-mph wind velocity.
- D. Sign Painter: Experienced as professional sign painter for minimum of three years.
- E. Finishes, Painting: Adequate to withstand weathering, fading, and chipping for duration of construction.
- F. Show content, layout, lettering, color, foundation, structure, sizes, and grades of members.
- G. Sign Materials:
 1. Structure and Framing: New wood, structurally adequate.
 2. Sign Surfaces: Exterior grade plywood with medium-density overlay, minimum of 3/4 inches thick, standard large sizes to minimize joints.
 3. Rough Hardware: Galvanized.
 4. Paint and Primers: Exterior quality, two coats; sign background of color as selected.
 5. Lettering: Exterior quality paint, contrasting colors as selected.
- H. Installation:
 1. Install Project identification sign within 15 days after date established by Notice to Proceed.
 2. Erect at designated location.
 3. Erect supports and framing on secure foundation, rigidly braced and framed to resist wind loadings.
 4. Install sign surface plumb and level, with butt joints. Anchor securely.
 5. Paint exposed surfaces of sign, supports, and framing.
- I. Maintenance: Maintain clean signs and supports; repair deterioration and damage.
- J. Removal: Remove signs, framing, supports, and foundations at completion of Project and restore area.

1.9 TRAFFIC REGULATION

- A. Signs, Signals, and Devices:
 1. Post-Mounted and Wall-Mounted Traffic Control and Informational Signs: As approved by authorities having jurisdiction.
 2. Traffic Control Signals: As approved by local jurisdictions.
 3. Traffic Cones, Drums, Flares, and Lights: As approved by authorities having jurisdiction.
 4. Flag Person Equipment: As required by authorities having jurisdiction.
- B. Flag Persons: Provide trained and equipped flag persons to regulate traffic when construction operations or traffic encroach on public traffic lanes.
- C. Flares and Lights: Use flares and lights during hours of low visibility to delineate traffic lanes and to guide traffic.
- D. Haul Routes:

28

1. Consult with authorities having jurisdiction and establish public thoroughfares to be used for haul routes and Site access.
2. Confine construction traffic to designated haul routes.
3. Provide traffic control at critical areas of haul routes to regulate traffic and to minimize interference with public traffic.

E. Traffic Signs and Signals:

1. Provide signs at approaches to Site and on Site, at crossroads, detours, parking areas, and elsewhere as needed to direct construction and affected public traffic.
2. Provide, operate, and maintain traffic control signals to direct and maintain orderly flow of traffic in areas under Contractor's control and areas affected by Contractor's operations.
3. Relocate signs and signals as Work progresses, to maintain effective traffic control.

F. Removal:

1. Remove equipment and devices when no longer required.
2. Repair damage caused by installation.
3. Remove post settings to depth of 2 feet.

1.10 BARRIERS

- A. Provide barriers to prevent unauthorized entry to construction areas, to allow for Owner's use of Site, and to protect existing facilities and adjacent properties from damage from construction operations and demolition.
- B. Tree and Plant Protection: Preserve and protect existing trees and plants designated to remain.
 1. Protect areas within drip lines from traffic, parking, storage, dumping, chemically injurious materials and liquids, ponding, and continuous running water.
 2. Provide 4-foot-high barriers around drip line, with access for maintenance.
 3. Replace trees and plants damaged by construction operations.
- C. Protect non-owned vehicular traffic, stored materials, Site, and structures from damage.

1.11 ENCLOSURES AND FENCING

- A. Construction: Commercial-grade chain-link fence or orange plastic construction netting.
- B. Provide 6-foot-high fence around construction Site; equip with vehicular and pedestrian gates with locks.
- C. Provide orange plastic construction netting around open excavations.

1.12 WATER CONTROL

- A. Grade Site to drain. Maintain excavations free of water. Provide, operate, and maintain necessary pumping equipment.
- B. Protect Site from puddles or running water. Provide water barriers as required to protect Site from soil erosion.

gab

1.13 DUST CONTROL

- A. Execute Work by methods that minimize raising dust from construction operations.
- B. Provide positive means to prevent airborne dust from dispersing into atmosphere.

1.14 NOISE CONTROL

- A. Provide methods, means, and facilities to minimize noise produced by construction operations.

PART 2 PRODUCTS - Not Used

PART 3 EXECUTION - Not Used

END OF SECTION

JK

SECTION 01 60 00 - PRODUCT REQUIREMENTS

PART 1 GENERAL

1.1 SECTION INCLUDES

- A. Products.
- B. Product delivery requirements.
- C. Product storage and handling requirements.
- D. Product options.
- E. Equipment electrical characteristics and components.
- F. Product substitutions and procedures.

1.2 PRODUCTS

- A. Specified products define standard of quality, type, function, dimension, appearance, and performance required.
- B. Furnish products of qualified manufacturers that are suitable for intended use. Furnish products of each type by single manufacturer unless specified otherwise. Confirm that manufacturer's production capacity can provide sufficient product, on time, to meet Project requirements.
- C. Domestic Products: Except where specified otherwise, domestic products are required and interpreted to mean products mined, manufactured, fabricated, or produced in United States or its territories.
- D. Do not use materials and equipment removed from existing premises except as specifically permitted by Contract Documents.
- E. Furnish interchangeable components from same manufacturer for components being replaced.

1.3 PRODUCT DELIVERY REQUIREMENTS

- A. Transport and handle products according to manufacturer's instructions.
- B. Promptly inspect shipments to ensure products comply with requirements, quantities are correct, and products are undamaged.
- C. Provide equipment and personnel to handle products; use methods to prevent soiling, disfigurement, or damage.

PART 2 PRODUCTS – Not Used

PART 3 EXECUTION - Not Used

END OF SECTION

Sub

SECTION 01 70 00 - EXECUTION AND CLOSEOUT REQUIREMENTS

PART 1 GENERAL

1.1 SECTION INCLUDES

- A. Field engineering.
- B. Closeout procedures.
- C. Project record documents.
- D. Product warranties and product bonds.
- E. Examination.
- F. Preparation.
- G. Execution.
- H. Cutting and patching.
- I. Protecting installed construction.
- J. Final cleaning.

1.2 FIELD ENGINEERING

- A. Owner will locate and Contractor shall protect survey control and reference points. Promptly notify Engineer of discrepancies discovered.
- B. Control datum for survey is established by Owner-provided survey indicated on Drawings.
- C. Contractor shall verify setbacks and easements; confirm Drawing dimensions and elevations.
- D. Protect survey control points prior to starting Site Work; preserve permanent reference points during construction.
- E. Promptly report to Engineer loss or destruction of reference point or relocation required because of changes in grades or other reasons.
- F. Contractor shall retain Engineer to replace dislocated survey control points based on original survey control.

1.3 CLOSEOUT PROCEDURES

- A. Prerequisites to Substantial Completion: Complete following items before requesting Certification of Substantial Completion, either for entire Work or for portions of Work:
 - 1. Submit maintenance manuals, Project record documents, digital images of construction photographs, and other similar final record data in compliance with this Section.

gds

2. Complete facility startup, testing, adjusting, balancing of systems and equipment, demonstrations, and instructions to Owner's operating and maintenance personnel as specified in compliance with this Section.
 3. Conduct inspection to establish basis for request that Work is substantially complete. Create comprehensive list (initial punch list) indicating items to be completed or corrected, value of incomplete or nonconforming Work, reason for being incomplete, and date of anticipated completion for each item. Include copy of list with request for Certificate of Substantial Completion.
 4. Obtain and submit releases enabling Owner's full, unrestricted use of Project and access to services and utilities. Include certificate of occupancy, operating certificates, and similar releases from authorities having jurisdiction and utility companies.
 5. Deliver tools, spare parts, extra stocks of material, and similar physical items to Owner.
 6. Make final change-over of locks and transmit keys directly to Owner. Advise Owner's personnel of change-over in security provisions.
 7. Discontinue or change over and remove temporary facilities and services from Project Site, along with construction tools, mockups, and similar elements.
 8. Perform final cleaning according to this Section.
- B. Prerequisites for Final Completion: Complete following items before requesting final acceptance and final payment.
1. When Contractor considers Work to be complete, submit written certification that:
 - a. Contract Documents have been reviewed.
 - b. Work has been examined for compliance with Contract Documents.
 - c. Work has been completed according to Contract Documents.
 - d. Work is completed and ready for final inspection.
 2. Submittals: Submit following:
 - a. Final punch list indicating all items have been completed or corrected.
 - b. Final payment request with final releases and supporting documentation not previously submitted and accepted. Include certificates of insurance for products and completed operations where required.
 - c. Specified warranties, workmanship/maintenance bonds, maintenance agreements, and other similar documents.
 - d. Accounting statement for final changes to Contract Sum.
 - e. Contractor's affidavit of payment of debts and claims on Contractor's Affidavit of Payment of Debts and Claims.
 - f. Contractor affidavit of release of liens on Contractor's Affidavit of Release of Liens.
 - g. Consent of surety to final payment on Consent of Surety to Final Payment Form.
 3. Perform final cleaning for Contractor-soiled areas according to this Section.

1.4 PROJECT RECORD DOCUMENTS

- A. Maintain on Site one set of the following record documents; record actual revisions to the Work:
1. Drawings.
 2. Specifications.
 3. Addenda.
 4. Change Orders and other modifications to the Contract.
 5. Reviewed Shop Drawings, product data, and Samples.
 6. Manufacturer's instruction for assembly, installation, and adjusting.

- B. Ensure entries are complete and accurate, enabling future reference by Owner.
- C. Store record documents separate from documents used for construction.
- D. Record information concurrent with construction progress, not less than weekly.
- E. Specifications: Legibly mark and record, at each product Section, description of actual products installed, including the following:
 - 1. Manufacturer's name and product model and number.
 - 2. Product substitutions or alternates used.
 - 3. Changes made by Addenda and modifications.
- F. Record Drawings and Shop Drawings: Legibly mark each item to record actual construction as follows:
 - 1. Include Contract modifications such as Addenda, supplementary instructions, change directives, field orders, minor changes in the Work, and change orders.
 - 2. Include locations of concealed elements of the Work.
 - 3. Identify depth of buried utility lines and provide dimensions showing distances from permanent facility components that are parallel to utilities.
 - 4. Dimension ends, corners, and junctions of buried utilities to permanent facility components using triangulation.
 - 5. Identify and locate existing buried or concealed items encountered during Project.
 - 6. Measured depths of foundations in relation to vertical datum.
 - 7. Measured horizontal and vertical locations of underground utilities and appurtenances, referenced to permanent surface improvements.
 - 8. Measured locations of internal utilities and appurtenances concealed in construction, referenced to visible and accessible features of the Work.
 - 9. Field changes of dimension and detail.
 - 10. Details not on original Drawings.
- G. Submit marked-up paper copy documents to Engineer with claim for final Application for Payment.
- H. Submit PDF electronic files of marked-up documents to Engineer with claim for final Application for Payment.

1.5 PRODUCT WARRANTIES AND PRODUCT BONDS

- A. Obtain warranties and bonds executed in duplicate by responsible Subcontractors, suppliers, and manufacturers within ten days after completion of applicable item of Work.
- B. Execute and assemble transferable warranty documents and bonds from Subcontractors, suppliers, and manufacturers.
- C. Verify documents are in proper form, contain full information, and are notarized.
- D. Co-execute submittals when required.
- E. Include table of contents and assemble in three D side ring binder with durable plastic cover.

- F. Submit prior to final Application for Payment.
- G. Time of Submittals:
 - 1. For equipment or component parts of equipment put into service during construction with Owner's permission, submit documents within ten days after acceptance.
 - 2. Make other submittals within ten days after date of Substantial Completion, prior to final Application for Payment.
 - 3. For items of Work for which acceptance is delayed beyond Substantial Completion, submit within ten days after acceptance, listing date of acceptance as beginning of warranty or bond period.

PART 2 PRODUCTS - Not Used

PART 3 EXECUTION

3.1 EXAMINATION

- A. Verify that existing Site conditions and substrate surfaces are acceptable for subsequent Work. Beginning new Work means acceptance of existing conditions.
- B. Verify that existing substrate is capable of structural support or attachment of new Work being applied or attached.
- C. Examine and verify specific conditions described in individual Specification Sections.
- D. Verify that utility services are available with correct characteristics and in correct locations.

3.2 PREPARATION

- A. Clean substrate surfaces prior to applying next material or substance according to manufacturer's instructions.
- B. Seal cracks or openings of substrate prior to applying next material or substance.
- C. Apply manufacturer-required or -recommended substrate primer, sealer, or conditioner prior to applying new material or substance in contact or bond.

3.3 EXECUTION

- A. Comply with manufacturer's installation instructions, performing each step in sequence. Maintain one set of manufacturer's installation instructions at Project Site during installation and until completion of construction.
- B. When manufacturer's installation instructions conflict with Contract Documents, request clarification from Engineer before proceeding.
- C. Verify that field measurements are as indicated on approved Shop Drawings or as instructed by manufacturer.

- D. Adjust operating products and equipment to ensure smooth and unhindered operation.
- E. Clean and perform maintenance on installed Work as frequently as necessary through remainder of construction period. Lubricate operable components as recommended by manufacturer.

3.4 CUTTING AND PATCHING

- A. Employ skilled and experienced installers to perform cutting and patching.
- B. Submit written request in advance of cutting or altering elements affecting:
 - 1. Structural integrity of element.
 - 2. Integrity of weather-exposed or moisture-resistant elements.
 - 3. Efficiency, maintenance, or safety of element.
 - 4. Visual qualities of sight-exposed elements.
 - 5. Work of Owner or separate contractor.
- C. Execute cutting, fitting, and patching including excavation and fill to complete Work and to:
 - 1. Fit the several parts together, to integrate with other Work.
 - 2. Uncover Work to install or correct ill-timed Work.
 - 3. Remove and replace defective and nonconforming Work.
 - 4. Remove samples of installed Work for testing.
 - 5. Provide openings in elements of Work for penetrations of mechanical and electrical Work.
- D. Execute Work by methods to avoid damage to other Work and to provide proper surfaces to receive patching and finishing.

3.5 PROTECTING INSTALLED CONSTRUCTION

- A. Protect installed Work and provide special protection where specified in individual Specification Sections.
- B. Provide temporary and removable protection for installed products. Control activity in immediate Work area to prevent damage.
- C. Prohibit traffic from landscaped areas.

3.6 FINAL CLEANING

- A. Execute final cleaning prior to final Project assessment.
- B. Clean debris from drainage systems.
- C. Clean Site; sweep paved areas, rake clean landscaped surfaces.
- D. Remove waste and surplus materials, rubbish, and construction facilities from Site.

END OF SECTION

46

SECTION 33 01 31 - MANHOLE GRADE ADJUSTMENT

PART 1 GENERAL

1.1 SUMMARY

A. Section Includes:

1. Raising manhole frames and covers.
2. Replacing manhole frames and covers.

1.2 UNIT PRICE - MEASUREMENT AND PAYMENT

A. Raising Manhole Frames and Covers:

1. Basis of Measurement: By each.
2. Basis of Payment: Includes removal and reinstalling manhole frame and cover, manhole rings and joint sealant.

B. Repairing Manhole Frames and Covers:

1. Basis of Measurement: By each.
2. Basis of Payment: Includes removal of old frame and cover, installing new frame and cover, and joint sealant.

1.3 REFERENCES

A. ASTM International:

1. ASTM A48/A48M - Standard Specification for Gray Iron Castings.
2. ASTM C32 - Standard Specification for Sewer and Manhole Brick (Made from Clay or Shale).
3. ASTM C531 - Standard Test Method for Linear Shrinkage and Coefficient Mortars, Grouts, Monolithic Surfacing, and Polymer Concretes.
4. ASTM C642 - Standard Test Method for Density, Absorption, and Voids in Hardened Concrete.
5. ASTM C672 - Standard Test Method for Scaling Resistance of Concrete Surfaces Exposed to Deicing Chemicals.
6. ASTM C990 - Standard Specification for Joints for Concrete Pipe, Manholes, and Precast Box Sections Using Preformed Flexible Joint Sealants.
7. ASTM D395 - Standard Test Method for Rubber Property - Compression Set.
8. ASTM D412 - Standard Test Methods for Vulcanized Rubber and Thermoplastic Elastomers-Tension.
9. ASTM D573 - Standard Test Method for Rubber-Deterioration in an Air Oven.
10. ASTM D575 - Standard Test Methods for Rubber Properties in Compression.
11. ASTM D2240 - Standard Test Method for Rubber Property-Durometer Hardness.
12. ASTM F593 - Standard Specification for Stainless Steel Bolts, Hex Cap Screws, and Studs.
13. ASTM F1554 - Standard Specification for Anchor Bolts, Steel, 36, 55, and 105-ksi Yield Strength.

Job

1.4 SUBMITTALS

- A. Section 01 33 00 - Submittal Procedures: Requirements for submittals.

1.5 CLOSEOUT SUBMITTALS

- A. Section 01 70 00 - Execution and Closeout Requirements: Requirements for submittals.
- B. Project Record Documents: Record actual grade adjustment elevation of manhole.

1.6 QUALIFICATIONS

- A. Manufacturer: Company specializing in manufacturing Products specified in this section.
- B. Installer: Company specializing in performing work of this section.

1.7 DELIVERY, STORAGE, AND HANDLING

- A. Accept materials on site in undamaged, unopened container, bearing manufacturer's original labels. Inspect for damage.
- B. Protect materials from damage by storage in secure location.

1.8 FIELD MEASUREMENTS

- A. Verify field measurements prior to fabrication.

PART 2 PRODUCTS

2.1 MANHOLE FRAMES, GRATES, RINGS AND COVERS

- A. Manufacturers:
 - 1. East Jordan Iron Works (EJ Group, Inc.)
 - 2. Neenah Foundry (Neenah Enterprises, Inc.)

2.2 RISER RINGS

- A. Rubber Adjustment Riser Rings:
 - 1. Flat or tapered.
 - 2. Physical properties as follows:

Physical Properties	Test Results	Test Method
Density	$\square \pm 1.098 \text{ g/cm}^3$	ASTM C642
Durometer Hardness		Based on ASTM D2240
Molded Surface	75A ± 10 points	
Interior Surface	73A ± 10 points	

406

Tensile Strength	232 psi (not less than 145 psi)	ASTM D412
Compression Deformation	under 145 psi	Based on ASTM D575
Initial Compression Deformation	6 ±4 percent	
Final Compression Deformation	6 ±4 percent	
Compression Set	0.4 percent (no more than 4 percent) under 145 psi	Based on ASTM D395
Freeze and Thaw When Exposed to Deicing Chemicals	No loss after 50 cycles	ASTM C672
Coefficient of Thermal Expansion	6x10 ⁻⁵ in/in/degree F	ASTM C531
Weathering	(70 hours at 158 degree F)	ASTM D573
Hardness Retained	100 percent ±5 percent	
Compressive Strength Retained	100 percent ±5 percent	
Tensile Strength Retained	100 percent ±5 percent	
Elongation Retained	100 percent ±5 percent	

- B. Nuts and Bolts:
 - 1. Hot-dipped galvanized ASTM F1554 – Standard Specification for Anchor Bolts, Steel, 36, 55 and 105-ksi Yield Strength.
- C. Accessories:
 - 1. Joint Sealant: ASTM C990 – Standard Specification for Joints for Concrete Pipe, Manholes, and Precast Box Sections Using Preformed Flexible Joint Sealants.
 - 2. Riser Rings.

PART 3 EXECUTION

3.1 EXAMINATION

- A. Section 01 30 00 - Administrative Requirements: Verification of existing conditions before starting work.
- B. Verify and locate manholes requiring grade adjustment.

3.2 CONSTRUCTION METHODS

- A. Frames, grates, rings and covers shall be constructed of the materials as specified and shall be placed carefully to the lines or grades as directed by the City.
- B. All welding shall conform to the requirements of the AWS-D-1-72 – Structural Welding Code. Welded frames, grates, rings and covers shall be hot-dipped galvanized (ASTM F1554 – Standard Specification for Anchor Bolts, Steel, 36, 55, and 105-ksi Yield Strength).
- C. Painting of gray iron castings will not be required, except when used in conjunction with structural steel shapes.

Sub

3.3 EXISTING WORK

- A. Saw cut existing paving, excavate, clean manholes, remove existing manhole frames and covers, and repair waterproofing.

3.4 ADJUSTING MANHOLE FRAMES AND COVERS

- A. Locate and raise manholes to grade.
- B. Use flat or tapered rubber manhole rings to achieve elevation indicated for frame and cover.
- C. Do not adjust elevation more than 6 inches with rubber manhole rings.
- D. Seal joints between manhole top, rubber rings, and frame with sealant.
- E. Reinstall removed manhole frame and cover.

3.5 REPLACING MANHOLE FRAMES AND COVERS

- A. Remove existing manhole frames and covers to enable reuse.
- B. Deliver removed manhole frames and covers to Owner as maintenance materials in accordance with Section 01 70 00 - Execution and Closeout Requirements.
- C. Install new frames and covers for manholes as indicated on Drawings. Adjust to match finished grade as indicated on Drawings. Seal joints between manholes and manhole frames.

3.6 PAVING RESTORATION

- A. Restore bituminous paving areas in accordance with TxDOT Item 351.

END OF SECTION



**CITY OF AUSTIN
STANDARD SPECIFICATIONS**

gdr

ITEM NO. 802S - PROJECT SIGNS (Revised 9-12-19)

802S.1 - Description

This item shall govern furnishing, fabricating, erecting, maintaining and removing Project Signs on Capital Improvement Projects (C.I.P.) and for project identification at other construction sites, when required on the Drawings. The C.I.P. signs shall be constructed as indicated on the Drawings.

This specification is applicable for projects or work involving either inch-pound or SI units. Within the text, the inch-pound units are given preference followed by SI units shown within parentheses.

802S.2 - Materials

A. Sign Face

Sign face shall be manufactured on standard exterior waterproof plywood sheets or other suitable material approved by the Engineer or designated representative. Unless indicated otherwise on the Standard Details or Drawings, the thickness of the plywood sheet shall be a minimum of 3/4 inches (19 mm).

B. Posts

Lumber posts, of the size indicated on the Standard Details or on the Drawings, shall be pressure treated with pentachlorophenol.

C. Paint

Exterior oil base paint, colors as indicated on the Standard Details or on the Drawings.

D. Decals for Capital Improvement Projects and Bond Program Projects

City seal shall be in color using a 3 color process. Electronic images are available from the City of Bastrop.

802S.3 - Installation

The signs shall be erected at a major entrance to the project for maximum public identification and exposure. At locations where construction is confined to a specific area, the installed sign size shall be 4 foot x 8 foot.

The signs shall be posted on portable wood frames or stanchions and will be located in the proximity of the work area as construction progresses. All lumber shall be painted with two coats of paint as indicated herein, in the Drawings.

In special cases the size of the sign may be changed to meet special requirements, but general proportions shall be maintained.

It shall be the responsibility of the contractor to maintain and relocate signs, if necessary during the progression of the project. Care shall be exercised to assure that placement of the signs does not interfere with or cause sight obstruction to vehicular and pedestrian traffic.

For projects located on a street with curb and gutter, signs shall be installed no closer than 2 feet (0.6 meter) from the face of curb on the street.

For projects located on a street without curb and gutter, signs shall be installed no closer than 6 feet (1.8 meters) from the edge of street pavement.

406

The contractor may install, at the Contractor's own expense, company signs to identify the contractor, architectural firm, etc. Signs are to be securely attached to the posts at locations indicated on the drawings and shall not be larger than 18 x 36 inches (0.45 x 0.90 meter).

802S.4 - Measurement

In the CIP contract, signs shall be measured by either lump sum or per each.

802S.5 - Payment

The work performed and the materials furnished as prescribed by this item shall be paid for by lump sum or per each price bid only. The "lump sum" bid or "per each" price bid shall include full compensation for all work performed and all materials furnished in constructing, transporting, maintaining and removing the signs as specified on the Drawings and as directed by the Engineer or designated representative.

Payment will be made under one of the following:

Pay Item No. 802S-AC.I.P.:	C.I.P. Project Signs	Lump Sum.
Pay Item No. 802S-BC.I.P.:	C.I.P. Project Sign	Per Each.
Pay Item No. 802S-ABOND:	Bond Project Signs	Lump Sum.
Pay Item No. 802S-BBOND:	Bond Project Sign	Per Each.

End

<u>SPECIFIC CROSS REFERENCE MATERIALS</u>	
<u>Specification Item No. 802S, "Project Signs"</u>	
<u>City of Austin Standard Details</u>	
<u>Designation</u>	<u>Description</u>
Item No. 802S-1	2.4 m x 1.2 m (8' x 4') C.I.P. Building Project Sign
Item No. 802S-1A	2.4 m x 1.2 m (8' x 4') Bond Program Building Project Sign
Item No. 802S-2	600 mm x 900 mm (24" x 36") C.I.P. Movable Sign Type II

Item No. 802S-2A	600 mm × 900 mm (24" × 36") Joint C.I.P. Movable Sign Type II
Item No. 802S-2B	900 mm . 1.2 m (36" × 48") Bond Program Project Movable Sign Type II
Item No. 804S-5	Typical CMTA/C.I.P. Sign Locations

406

Technical Specifications for TxDOT

The Texas Department of Transportation "Standard Specifications for Construction and Maintenance of Highways, Streets, and Bridges," 2014 Edition, is incorporated herein by reference for all intents and purposes. If a standard specified in that document conflicts with a standard included within a bid specifications document, the standard in the bid specifications document controls. If the standard is still unclear, the Engineer will determine which standard controls and his determination shall be final.

Ad

Special Specification 3005

Scrub Seal Treatment



1. DESCRIPTION

Construct a surface treatment consisting of 1 or more applications of a single layer of asphalt emulsion that is scrubbed with a broom and covered with a single layer of aggregate.

2. MATERIALS

Furnish materials of the type and grade shown on the plans in accordance with the following:

- Polymer modified emulsion that meets the requirements of Item 300, "Asphalts, Oils, and Emulsions" Table 10 CMS-2P.
- Item 302, "Aggregates for Surface Treatments." Furnish aggregate of the type and grade shown on the plans and listed in Table 1. Ensure the aggregate gradation meets the requirements in Table 2 for the specified grade when tested in accordance with Tex-200-F, Part I. Furnish aggregates that meet the quality requirements shown in Table 3, unless otherwise shown on the plans.

For final surfaces, unless otherwise shown on the plans, furnish aggregate with a surface aggregate classification of "B" or better. Provide aggregates from sources listed in the Department's Bituminous Rated Source Quality Catalog (BRSQC). Use material not listed or not meeting the requirements of the BRSQC only when tested by the Engineer and approved before use. Allow 30 calendar days for testing of material from such sources.

3. EQUIPMENT

3.1. **Distributor.** Furnish a distributor that will apply the emulsion uniformly at the specified rate or as directed.

3.1.1. **Calibration.** Furnish a volumetric calibration and strap stick for the distributor tank in accordance with Tex-922-K, Part I. Provide documentation of distributor calibration performed not more than 5 yr. before the date first used on the project. The Engineer may verify calibration accuracy in accordance with Tex-922-K, Part II.

3.1.2. **Computerized Distributor.** When paying for emulsion by weight, the Engineer may allow use of the computerized distributor display to verify application rates. Verify application rate accuracy at a frequency acceptable to the Engineer.

3.2. **Aggregate Spreader.** Use a continuous-feed, self-propelled spreader to apply aggregate uniformly at the specified rate or as directed.

3.3. **Rollers.** Unless otherwise shown on the plans, furnish light pneumatic tire rollers in accordance with Item 210, "Rolling."

3.4. **Scrub Broom.** Furnish a scrub broom assembly of similar design to Exhibit A or B, as approved by the engineer, and having the following characteristics:

- Rigid frame construction,
- Attached to, and pulled by, the distributor,
- Of such weight that it does not squeegee the emulsion off the roadway surface,
- Leading and trailing broom heads angled at 10 to 15 degrees off the centerline of the supporting member,
- Stiff bristles with a minimum height of five inches, and
- Hinged wing assemblies or other means of adjusting the broom width.

Provide a means of raising the broom from the road surface at desired points, and for towing the broom in elevated position when moving between shots.

- 3.5. **Power Broom.** Furnish a rotary, self-propelled broom for initial sweeping and final surface sweeping.
- 3.6. **Emulsion Storage and Handling Equipment.** When the plans or the Engineer allows storage tanks, furnish a thermometer in each tank to indicate the emulsion temperature continuously. Keep equipment clean and free of leaks. Keep emulsion free of contamination.
- 3.7. **Aggregate Haul Trucks.** Unless otherwise authorized, use trucks of uniform capacity to deliver the aggregate. Provide documentation showing measurements and calculation in cubic yards. Clearly mark the calibrated level. Truck size may be limited when shown on the plans.
- 3.8. **Digital Measuring Instrument.** Furnish a vehicle with a calibrated digital-measuring instrument accurate to ± 6 ft. per mile.

4. CONSTRUCTION

- 4.1. **General.** Application season will be as shown on the plans. Emulsion and aggregate rates shown on the plans are for estimating purposes only. The Engineer will adjust the rates for the existing conditions.
- 4.2. **Temporary Aggregate Stockpiles.** The Engineer will approve the location of temporary aggregate stockpiles on the right of way before delivery. Place stockpiles in a manner that will not:
 - obstruct traffic or sight distance,
 - interfere with the access from abutting property, or
 - interfere with roadway drainage.

Locate stockpiles a minimum of 30 ft. from roadway when possible. Sign and barricade as shown on the plans.
- 4.3. **Aggregate Furnished by the Department.** When shown on the plans, the Department will furnish aggregate to the Contractor without cost. Stockpile locations are shown on the plans.
- 4.4. **Adverse Weather Conditions.** Do not place surface treatments when, in the Engineer's opinion, general weather conditions are unsuitable. Meet the requirements for air and surface temperature shown below.
- 4.4.1. **Standard Temperature Limitations.** Apply scrub seal when air temperature is above 50°F and rising. Do not apply surface treatment when air temperature is 60°F and falling. In all cases, do not apply surface treatment when surface temperature is below 60°F.
- 4.4.2. **Cool Weather Night Air Temperature.** The Engineer reserves the right to review the National Oceanic and Atmospheric Administration (NOAA) weather forecast and determine if the nightly air temperature is suitable for placement to prevent aggregate loss.
- 4.4.3. **Cold Weather Application.** When application is allowed outside of the above temperature restrictions, the Engineer will approve the emulsion grade and the air and surface temperatures for application. Apply scrub seal at air and surface temperatures as directed.
- 4.5. **Surface Preparation.** Remove existing raised pavement markers. Repair any damage incurred by removal as directed. Remove dirt, dust, or other harmful material before sealing. Cracks in the pavement must be cleaned of debris using compressed air. When shown on the plans, remove vegetation and blade pavement edges.
- 4.6. **Rock Land and Shot.**
- 4.6.1. **Definitions.**

- A "rock land" is the area covered at the aggregate rate directed with 1 truckload of aggregate.
- A "shot" is the area covered by 1 distributor load of emulsion.

4.6.2 **Setting Lengths.** Calculate the lengths of both rock land and shot. Adjust shot length to be an even multiple of the rock land. Verify that the distributor has enough emulsion to complete the entire shot length. Mark shot length before applying emulsion. When directed, mark length of each rock land to verify the aggregate rate.

4.7. **Emulsion Placement.**

4.7.1. **General.** Adjust the shot width so operations do not encroach on traffic or interfere with the traffic control plan, as directed. Use paper or other approved material at the beginning and end of each shot to construct a straight transverse joint and to prevent overlapping of the emulsion. Unless otherwise approved, match longitudinal joints with the lane lines. The Engineer may require a string line if necessary to keep joints straight with no overlapping. Use sufficient pressure to flare the nozzles fully. Select an application temperature, as approved, in accordance with Item 300. Uniformly apply the emulsion at the rate directed, within 15°F of the approved temperature, and not above the maximum allowable temperature.

4.7.2. **Scrubbing.** Mechanically scrub the freshly applied emulsion by dragging the scrub broom behind the distributor, so that the emulsion is evenly spread over the road surface and fills existing surface cracks.

4.7.3. **Limitations.** Do not apply emulsion to the roadway until:

- traffic control methods and devices are in place as shown on the plans or as directed,
- the loaded aggregate spreader is in position and ready to begin,
- haul trucks are loaded with enough aggregate to cover the shot area, and
- haul trucks are in place behind the spreader box.

4.7.4. **Non-uniform Application.** Stop application if it is not uniform due to streaking, ridging, puddling, flowing off the roadway surface, or not filling the cracks. Verify equipment condition, operating procedures, application temperature, and material properties. Determine and correct the cause of non-uniform application. If the cause is high or low emulsion viscosity, replace emulsion with material that corrects the problem.

4.7.5. **Test Strips.** The Engineer may stop application and require construction of test strips at the Contractor's expense if any of the following occurs:

- non-uniformity of application continues after corrective action;
- on 3 consecutive shots, application rate differs by more than 0.03 gal. per square yard from the rate directed; or
- any shot differs by more than 0.05 gal. per square yard from the rate directed.

The Engineer will approve the test strip location. The Engineer may require additional test strips until surface treatment application meets specification requirements.

4.8. **Aggregate Placement.** As soon as possible, apply aggregate uniformly at the rate directed without causing the rock to roll over.

4.9. **Rolling.** Start rolling operation on each shot as soon as aggregate applied. Use sufficient rollers to cover the entire mat width in 1 pass, i.e., 1 direction. Roll in a staggered pattern. Unless otherwise shown on the plans, make a minimum of 3 passes. If rollers are unable to keep up with the spreader box, stop application until rollers have caught up, or furnish additional rollers. Keep roller tires asphalt-free.

4.10. **Patching.** Before rolling, repair spots where coverage is incomplete. Repair can be made by hand spotting or other approved method. When necessary, apply additional emulsion to embed aggregate.

4.11. **Finishing Broom.** After rolling, sweep as soon as aggregate has sufficiently bonded to remove excess.

- 4.12. **Final Acceptance.** Maintain surface treatment until the Engineer accepts the work. Repair any surface failures. Before final project acceptance, remove all temporary stockpiles and restore the area to the original contour and grade.

5. MEASUREMENT

- 5.1. **Emulsion.** Unless otherwise shown on the plans, emulsion will be measured by one of the following methods:
- 5.1.1. **Volume.** Emulsion will be measured at the applied temperature by strapping the tank before and after road application and determining the net volume in gallons from the distributor's calibrated strap stick. The quantity to be measured for payment will be the number of gallons used, as directed, in the accepted surface treatment.
- 5.1.2. **Weight.** Emulsion will be measured in tons using certified scales meeting the requirements of Item 520, "Weighing and Measuring Equipment," unless otherwise approved. The transporting truck must have a seal attached to the draining device and other openings. The Engineer may require random checking on public scales at the Contractor's expense to verify weight accuracy. Upon work completion or temporary suspension, any remaining emulsion will be weighed by a certified public weigher, or measured by volume in a calibrated distributor or tank and the quantity converted to tons at the measured temperature. The quantity to be measured will be the number of tons received minus the number of tons remaining after all directed work is complete and minus the amount used for other items.
- 5.2. **Aggregate.** Aggregate will be measured by the cubic yard in the trucks as applied on the road. The Engineer may require loaded aggregate to be struck off for accurate measurement.
- 5.3. **Loading, Hauling, and Distributing Aggregate.** When the Department furnishes the aggregate, the loading, hauling, and distributing will be measured by the cubic yard in the trucks as applied on the road.

6. PAYMENT

The work performed and materials furnished in accordance with this Item and measured as provided under "Measurement" will be paid for at the unit prices bid for "Emulsion," "Aggregate," and "Loading, Hauling, and Distributing Aggregate" of the types-grades specified. These prices are full compensation for surface preparation; furnishing, preparing, hauling, and placing materials; removing existing pavement markers and excess aggregate; rolling; cleaning up stockpiles; and equipment, labor, tools, and incidentals.

Exhibit A

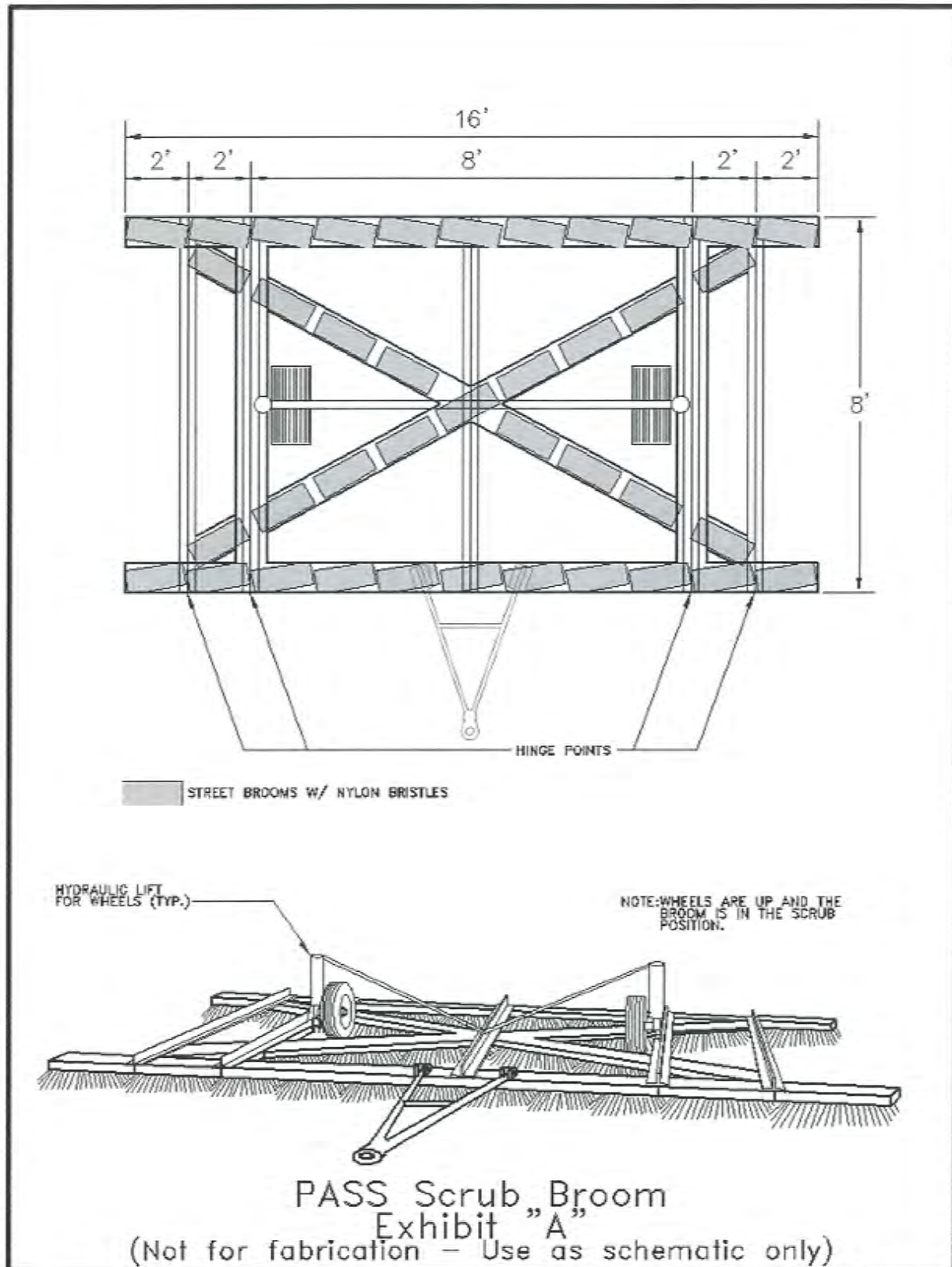

John

Exhibit B

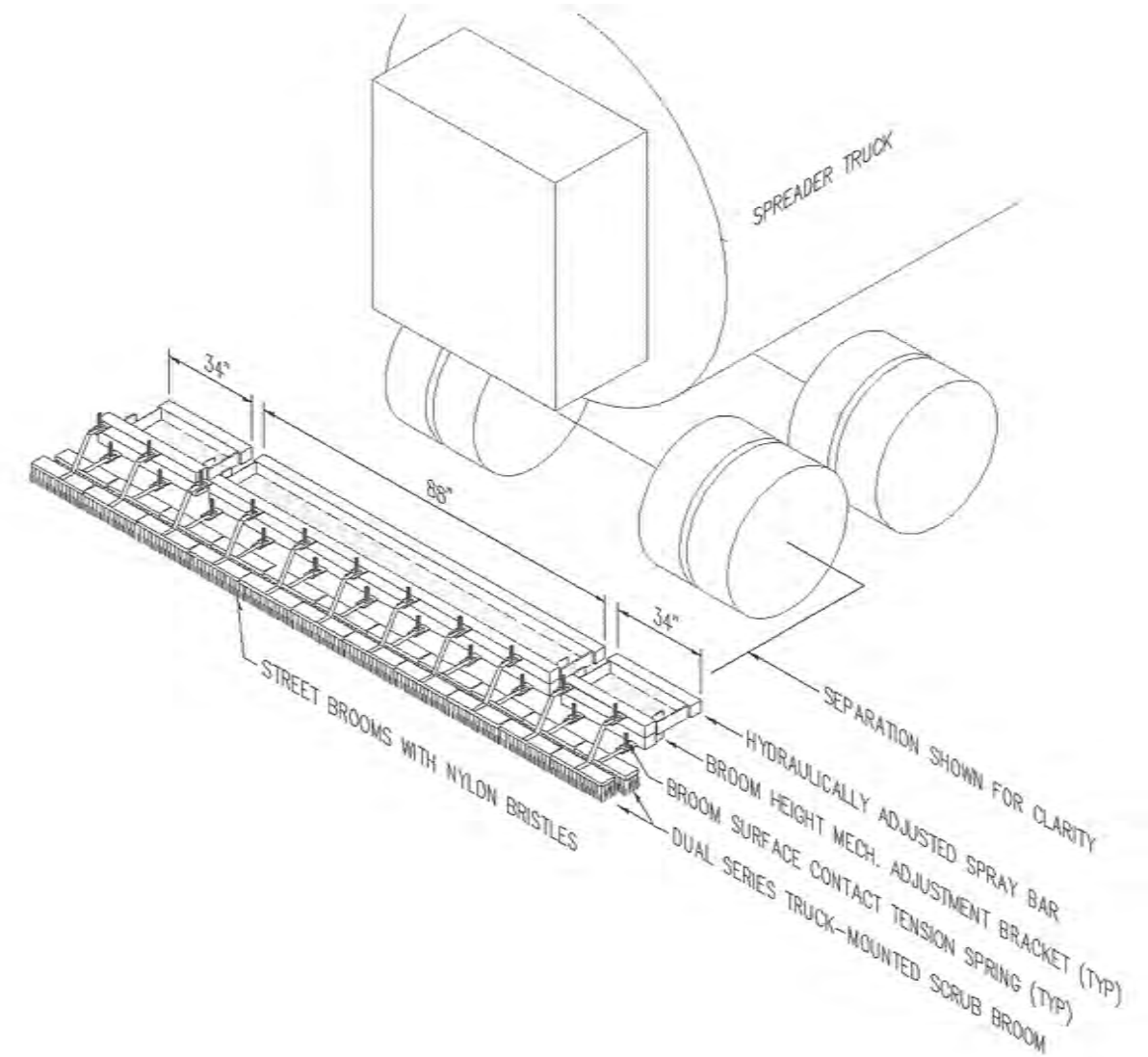

Truck Mounted Scrub Broom

Special Specification 3028

Frictional Asphaltic Surface Preservation Treatment



1. DESCRIPTION

Apply a surface preservation treatment consisting of one or more applications of a single layer of asphaltic and aggregate material.

2. MATERIALS

Furnish materials in accordance with the following:

2.1. Asphalt.

Furnish an emulsified asphalt in accordance with Table 1. Provide water in accordance with Article 204.2., "Materials."

Table 1. Emulsified Asphalt

Property	Test Procedure	Min	Max
Viscosity	T 59	20	100
Particle Charge Test	T 59	Positive	
Sieve, %	T 59	0	0.1
Residue by Distillation, percent	T 59	60	-
Penetration at 77°F, 100 g, 5 sec.	T 49	40	150

Use a quantity of emulsified asphalt in the mixture, expressed as a percentage of total weight, the percentage shown on the plans, or as directed.

2.2. Aggregate.

Furnish aggregate meeting Item 302, "Aggregates for Surface Treatments," of the grade shown in Table 2.

Table 2. Aggregates

Physical Properties ¹			
Property	Test Procedure	Min.	Max.
Water Absorption, %	T 84	-	4
Micro-Deval, %	D 7428 ²	-	20
Gradation ³			
Sieve	Standard	Master Grading Band Limits Percent Passing	Target Tolerance
No. 8	C 136	100	
No. 16	C 136	85-100	
No. 30	C 136	75-100	± 5
No. 60	C 136	10-40	± 5
No. 100	C 136	0-10	± 5
No. 200	C 117	0-5	± 1

1. Perform physical property tests on aggregates that are received before blending into sealer.
2. Micro-Deval on aggregate larger than No. 60 sieve U.S.

2.3. Additives.

Add clay, polymers, water, and other additives as required. Use a minimum of 4% polymer by weight. Furnish water free of industrial wastes and other objectionable matter.

or:

for

Other Additives. Use approved additives as recommended by the Frictional Asphaltic Surface Preservation Treatment manufacturer when necessary to adjust mix time in the field.

3. MIX DESIGN

3.1 Furnish a laboratory mix design meeting the requirements shown in Table 3:

Table 3. Laboratory Mix Design

Test	Test Procedure	Min	Max
Wet-Track Abrasion Loss, 3 day soak, g/m ²	D 3910 ¹	—	80
Asphalt Content by Ignition Method, %	T 308	30	—
Dynamic Friction Test Number, 20 kph	E 1911 ²	0.90	—

1. Use the modified method to account for realistic application depth and fine emulsion mixture.
2. Establish base friction value using prepared laboratory compacted slab of approved mix as surface to be tested. The Dynamic Friction Test (DFT) number ratio should indicate that after application of the mastic seal, the surface retains required minimum percentage DFT number of the original pavement surface.

3.2 Furnish a production or field sample meeting the requirements shown in Table 4:

Table 4. Production or Field Sample

Test	Test Procedure	Min	Max
Solids Content by Evaporation, %	T 59 ¹	48	—
Asphalt Content by Ignition Method, %	T 308 ³	30	—
Rotational Viscosity, 20 rpm, RV spindle, 25°C, cP	D 2196 ²	800	4000
Temperature for storage and application, °F	—	60	130

1. Dry specimens to a state where measurements taken 20 minutes apart do not change.
2. Test samples within 7 days.
3. Reduce sample size to achieve asphalt quantity. It is very important that this test be performed on a completely dry sample.

4. EQUIPMENT

- 4.1 **Mixing Plant.** Provide a stationary pugmill, weigh-batch, or continuous mixing plant as approved. Equip plants with digital proportioning and metering devices that produce a uniform mixture of asphalt, aggregate and additives in the specified proportions.
- 4.2 **Distributor.** Provide applicable equipment in accordance with Article 316.3., "Equipment." Furnish the necessary facilities and equipment for determining the temperature of the mixture, regulating the application rate, and securing uniformity at the junction of 2 distributor loads. Furnish a distributor capable of keeping the Frictional Asphaltic Surface Preservation Treatment in uniform suspension and adequately mixing the asphalt, aggregate and additives.
- 4.3 **Asphalt Storage and Handling Equipment.** When using storage tanks, furnish a thermometer in each tank to continuously indicate the asphalt temperature. Keep equipment clean and free of leaks. Keep asphalt material free of contamination. Furnish storage tanks capable of keeping the Frictional Asphaltic Surface Preservation Treatment in uniform suspension and adequately mixing the asphalt, aggregate and additives.

5. CONSTRUCTION

- 5.1 **Adverse Weather Conditions.** Do not place mixture when, in the Engineer's opinion, general weather conditions are unsuitable. Meet the requirements for air and surface temperature shown below.
- 5.1.1 **Standard Temperature Limitations.** Apply mixture when air temperature is above 50°F and rising. Do not apply mixture when air temperature is 60°F and falling. In all cases, do not apply mixture when surface temperature is below 60°F.

- 5.1.2. **Cool Weather Night Air Temperature.** The Engineer reserves the right to review the **National Oceanic and Atmospheric Administration (NOAA)** weather forecast and determine if the nightly air temperature is suitable for mixture placement.
- 5.1.3. **Cold Weather Application.** When mixture application is allowed outside of the above temperature restrictions, the Engineer will approve the mixture and the air and surface temperatures for application. Apply mixture at air and surface temperatures as directed.
- 5.2. **Surface Preparation.** Remove existing raised pavement markers. Repair any damage incurred by removal as directed. Remove dirt, dust, or other harmful material before applying. When shown on the plans, remove vegetation and blade pavement edges.
- 5.3. **Application.** Apply the mixture when the air temperature is at or above 60°F, or above 50°F and rising. Measure the air temperature in the shade away from artificial heat. The Engineer will determine when weather conditions are suitable for application.
- Distribute material at the following rates or as directed:
- First application: 1.0 to 1.5 lbs per SY.
 - Second application: 1.0 to 1.5 lbs per SY.
 - Total application after the second application: 2.5 lbs per SY minimum.
- 5.4. **Edges.** Adjust the shot width so operations do not encroach on traffic or interfere with the traffic control plan, as directed. Use paper or other approved material at the beginning and end of each shot to construct a straight traverse joint. Unless otherwise approved, match longitudinal joints with the lane lines. The Engineer may require a string line if necessary to keep the edge straight. Use sufficient pressure to flare the nozzles fully.
- 5.5. **Workmanship.** Immediately take corrective action if treatment material is exhibiting evidence of poor workmanship, delayed opening to traffic, or surface irregularities, including streaks, uncoated, and blotchy areas. The Engineer may allow placement to continue for no more than one day of production while taking appropriate action. Suspend application if the problem still exists after one day until the problem is corrected to the satisfaction of the Engineer.
- 5.6. **Opening to Traffic.** Open the treated surface to traffic when directed. Furnish and uniformly distribute clean, fine sand on the surface to blot the excess when an excessive quantity of mixture is applied. Maintain ingress and egress as directed by applying sand to freshly treated areas.

6. MEASUREMENT

Frictional Asphaltic Surface Preservation Treatment will be measured by the ton or by the square yard of the composite Frictional Asphaltic Surface Preservation Treatment mixture, which includes asphalt emulsion, aggregate, and additives. At the completion of the project, any unused Frictional Asphaltic Surface Preservation Treatment will be weighed back and deducted from the accepted Frictional Asphaltic Surface Preservation Treatment quantity delivered.

7. PAYMENT

The work performed and materials furnished in accordance with this Item and measured as provided under "Measurement" will be paid for at the unit bid price per ton or square yard for "Frictional Asphaltic Surface Preservation Treatment." This price is full compensation for preparing the existing surface (including removing existing raised pavement markers); furnishing, hauling, preparing, and placing materials; and equipment, labor, tools, and incidentals.

ATTACHMENTS

92

SPECIAL PROVISIONS

TABLE OF CONTENTS

<u>SECTION NUMBER</u>	<u>DESCRIPTION</u>
SP1	CITY PROJECT MANAGER
SP2	CONSTRUCTION PHASING/TRAFFIC CONTROL
SP3	RESIDENTIAL NOTIFICATION
SP4	SOLID WASTE COORDINATION
SP5	SCHEDULE
SP6	CLEANUP OF LOOSE ROCK
SP7	ROCK RATE



SPECIAL PROVISIONS

- SP1 CITY PROJECT MANAGER:** The City of Bastrop's official representative shall be Curtis Hancock. He may be reached at 1311 Chestnut St., Bastrop, TX 78602, 512-332-8960.
- SP2 CONSTRUCTION PHASING/TRAFFIC CONTROL:** Contractor shall provide and adhere to an approved traffic control plan based on the Texas Manual on Uniform Traffic Control Devices (TMUTCD). The contractor is solely responsible for traffic control including all signs, barricades, markings, flagmen, pilot cars, patrol officers, and/or any other traffic control devices that will be appropriate for the construction or maintenance of the roadway or other associated work. The contractor's traffic control plan shall be completed for review during the pre-construction meeting. Contractor will be required to provide and maintain detours for street segments that are closed for construction. Any closures or detour routes **MUST BE PRE-APPROVED** by the Project Manager and/or his designee. The contractor shall update the traffic control plan as required during construction. All traffic control shall comply with the TMUTCD. The contractor's plan must be approved by the City Project Manager prior to beginning work.
- SP3 RESIDENTIAL NOTIFICATION:** Prior to beginning construction, the residents and business owners within the affected work zone shall be notified by the Contractor at least **72 hours in advance**. Notification shall be written and hand delivered to each residence or business. Notices are not to be placed in mailboxes. All written notices shall be approved by the City prior to distribution. Residents shall be similarly notified if access to their drives will be blocked for any period of time. The Contractor shall accommodate Special Needs that residents may have such as access for handicap, etc.
- SP4 SOLID WASTE COORDINATION:** Construction is not to impede weekly waste collection. Residential waste and brush & bulky service occur once per week. The schedules are available at the City of Bastrop website:
<https://www.cityofbastrop.org/upload/page/0128/docs/BastropServiceMap4.pdf>

The contractor is to work with the City of Bastrop Solid Waste Division to make certain the impact to citizens is minimized. The contractor is to work with the City as need including scheduling, assisting in relocation of garbage cans, etc. Whenever city garbage collection trucks are denied vehicular access to residential curbside pickup, the contractor must collect the filled cans from each property and locate them in an area accessible to the collection truck prior to the scheduled pickup. The contractor must also return the empty cans that same day. The contractor may note on the door hanger notifications that residential waste pickup

26

will occur on regularly scheduled days but that pick-up will occur as early as 7:00 am during this time to facilitate construction.

- SP5 SCHEDULE:** The City of Bastrop would like this contract to be complete on or before July 31, 2020. Detail Sheet C003 further outlines schedule parameters. Seal coat work shall not commence complete prior to May 15, 2020. Scrub seal work, Fog Seal Work and Frictional Asphaltic Surface Preservation Treatment shall not commence prior to April 15, 2020. Crack seal work shall commence as soon as possible and be completed prior to March 15, 2020. There are no restrictions on 5" Flexible Pavement Repair work provided that Weather Conditions as shown in Item 340.4.6.1 are met, but Pavement Repair areas shall be marked prior to commencement of Crack Seal Work so that Crack Seal Work does not occur in areas of Flexible Pavement Repair. Normal construction hours will be conducted Monday through Friday between the hours of 8:00 am and 5:00 pm. Work occurring around schools shall be scheduled so that work does not interfere with school zone traffic during drop-off and pick-up schedule times. Work may be allowed on Saturdays with Project Manager approval. There will be no work allowed on Sunday.
- SP6 SWEEPING AND PICKUP OF LOOSE ROCK:** All streets shall be fully/completely swept and all loose rock picked up within 24 hours of Seal Coat and Scrub Seal operations. Contractor shall provide a second sweep and loose rock pickup to all treated roadways fourteen (14) days after the first sweep. Loose rock shall be picked up and discarded properly from grass, medians, curbs, gutters, driveways, adjacent roadways, intersections, etc. at the 24 hour and 14-day intervals. This will not constitute the only sweeping and pickup of loose rock. Additional sweeping and loose rock pickup may be required at additional times (i.e. punch list and/or staff or resident concerns).
- SP7 ROCK RATE:** The rock rate for Seal Coat and Scrub Seal operations is 1 CY/110 SY. This is the basis of estimate amount of rock allowed on the roadway. Contractor may, with City of Bastrop approval, adjust the rock rate lower but must still provide the maximum coverage for the surface treatment operation to prevent an abundance of loose rock.

GENERAL NOTES

1. GENERAL

- 1.1 All work shall be done in accordance with plans, drawings, and specifications and in the best and most workmanlike manner by qualified, careful and efficient workers, in strict conformity with the best accepted practices of each craft concerned, and at all times workmanship shall be subject to inspection and approval of the City through the Project Manager.
- 1.2 Right of Way – Facility and Utility Protection – The Contractor shall be responsible for adequately protecting all facilities (mailboxes, fences, trees, bushes, sidewalks, curb and gutter, driveways, etc.) not designated for removal during construction. Any damage to existing facilities incurred as a result of construction operations shall be immediately repaired by the Contractor to existing or better condition. All repairs shall be approved by the City through the Project Manager. The cost of the restoration shall be borne by the Contractor.
- 1.3 The Contractor shall maintain access to existing driveways at all times.
- 1.4 All adjoining pavement sections (including driveways) shall be protected during construction. Any damages incurred due to the Contractor's operation, shall be repaired and/or replaced to match or exceed existing conditions at the Contractor's expense.
- 1.5 Where existing pavement (including driveways) adjoins new pavement, the existing pavement shall be sawed to a neat transverse and/or longitudinal line to permit proper joining. This work is considered subsidiary to the various bid items.
- 1.6 The Contractor shall use rubber-tired equipment for moving materials along or across paved surfaces and shall protect the pavement from all damage when moving equipment that is not licensed for operation on City streets.
- 1.7 Mixing of materials, storing of materials, storing of equipment, or repairing of equipment on top of pavement will not be permitted unless specifically authorized by the City through the Project Manager. Permission may be granted to store materials on surfaces, if in the opinion of the Project Manager, no damage or discoloration will result.
- 1.8 The Contractor shall provide continuous supervision of construction and a superintendent shall be on the project site at all times during working hours.
- 1.9 Quantities are estimated. It is the Contractor's responsibility to check quantities which will be approved by the Engineer. Quantities will be verified by Contractor before work begins. Square yards will include radius and cul-de-sacs.

- 1.10 The Contractor will get prior approval for all stockpile sites for construction in writing from the Project Manager's approval prior to stock piling materials.
- 1.11 The Contractor will furnish all labor, material and equipment to complete the work.

2. TRAFFIC CONTROL PLAN/TRAFFIC CONTROL IMPLEMENTATION

- 2.1 Traffic Control Plan:
 - 2.1.1 Basis of Measurement: Lump Sum
 - 2.1.2 Basis of Payment: Payment for Traffic Control Plan shall be made at the lump sum bid for "Traffic Control Plan". Payment for all work prescribed under this item shall be full compensation for the Traffic Control Plan including all preparation, submittals, updates and revisions.
- 2.2 Traffic Control Implementation:
 - 2.2.1 Basis of Measurement: Lump Sum
 - 2.2.2 Basis of Payment: Includes all aspects of implementing the Plan throughout the Project.
- 2.3 The Contractor will be responsible for erecting and maintaining all barricades, flaggers, signs and other devices necessary to protect the public and maintain traffic flow when he is working in or adjacent to the public right-of-way.
- 2.4 The Contractor shall regulate all construction activities and equipment so as to cause a minimum of inconvenience to the traveling public. At points where it is necessary for trucks to stop, load, or unload, provide warning signs and flaggers to protect the traveling public.
- 2.5 All flagmen shall be equipped with communications devices (i.e., 2-way radios).
- 2.6 TCP must be developed to address the specific conditions of the planned construction work location. The roadway may not be closed to local traffic except for very short duration(s). i.e. during crack seal operations, seal coat operations, scrub seal operations, fog seal operations or final surface HMAC operations.
- 2.7 Roadways at intersections may not be closed to thru traffic except for short duration(s). i.e. during crack seal operations, seal coat operations, scrub seal operations, fog seal operations or final surface HMAC operations.
- 2.8 Traffic control shall conform to applicable requirements of the Texas Manual of Uniform Traffic Control Devices (TMUTCD)(latest edition). Adequate signs, barricades, flag personnel, etc. shall be erected and maintained in full compliance with the TMUTCD.
- 2.9 TCP's may utilize TMUTCD typical applications such as TA-8 (for intersections), TA-18 or TA-20.

- 2.10 Contractor shall provide all traffic control measures to prosecute the work. The driveways for each residence in the cul-de-sac shall have cones or TY III barricades placed to remind residents of fog seal work or Frictional Asphaltic Surface Preservation Treatment work.
- 2.11 Contractor shall assign at least one competent employee to each cul-de-sac that has received a Surface Treatment application but has not yet been opened to traffic. This employee will ensure that traffic does not drive on a non-cured Surface Treatment seal. Traffic control suitable methods shall be used by the Contractor to protect the Surface Treatment seal from all types of vehicular traffic without damage. Opening to traffic does not constitute acceptance of the work. Project Manager shall be notified of the methods to be used.
- 2.12 The Contractor will be required to maintain a minimum of one through lane in each direction during daylight hours, on all roadways, except with the written approval by the Project Manager.
- 2.13 Two lane roadways shall use single lane traffic control, which will require the use of flagmen. Old Austin Highway shall maintain traffic in each direction with the use of flagmen while work is ongoing.
- 2.14 Ensure equipment and materials are a minimum ten (10) feet from the edge of the traveled roadway during non-working hours.
- 2.15 Perform all construction work in daylight hours unless the Project Manager approves nighttime work in writing. Remove all construction equipment from the road thirty (30) minutes prior to sunset and determined by NOAA.
- 2.16 Qualify all flaggers used on this project to perform flagging duties. Provide a list of qualified flaggers prior to beginning any road work activities which require flagging. Provide flaggers with a Slow/ Stop paddle and with an approved flagging vest and hard hat.
- 2.17 Remove from the roadway and store in a central location approved by the engineer all temporary traffic control devices, such as cones, barrels, portable signs, vertical panels, etc., which will not be used in twenty-four (24) hours. This includes removal of temporary traffic control devices from the roadway over the weekend.

3. SEAL COAT

- 3.1 Asphalt Oils and Emulsions shown on bid tabs will be used unless otherwise approved in writing by the Engineer. Aggregate cover stone will be as shown on bid proposal unless otherwise approved by the Engineer in writing. All aggregates are to be SAC-B.

- 3.2 Open Season for application of asphalt oils and emulsions is from May 15 through October 1. No seal coat surface treatment shall be placed between October 1 and May 15.
- 3.3 The Contractor shall furnish samples of materials to the City for testing prior to application to the roadway. The City shall, at any time during construction, perform random testing throughout the construction period.
- 3.4 The Contractor shall have access to a minimum of four (4) 10-yard dump trucks, or six (6) 5-yard dump trucks.
- 3.5 The Contractor shall have a distributor with the capability of applying 22' maximum width.
- 3.6 Overweight trucks will NOT be permitted to supply the chip spreader.
- 3.7 All excess/unused material shall be removed from all work site areas within thirty (30) days or it will become property of City of Bastrop.
- 3.8 The Contractor shall have a minimum of (12) "Loose Gravel" signs available for posting during construction.
- 3.9 The Contractor shall set his own shots and station numbers as needed throughout each section of the project. Asphalt and aggregate rates shall be conveyed and agreed upon by Project Manager prior to shots beginning. Asphalt rates and aggregate rates shown in bid documents are to be considered average rates.
- 3.10 Contractor shall protect adjacent sections at beginning and ending shots with paper. Additionally, all manhole covers, valve covers, etc. shall be protected from asphalt during surface treatment operations.
- 3.11 Protect all existing curbs, concrete valley gutters, and other exposed concrete surfaces within the limits of the projects as much as practical from asphalt materials by any method that is acceptable to the Project Manager. Contractor shall be required to remove any excess asphalt materials deposited on these surfaces in a manner approved by the Project Manager at the Contractor's expense.
- 3.12 Wind velocities in excess of 20 mph shall be considered as inclement weather and work will be suspended. Wind velocities will be determined at the nearest airport to the work area.



G:\PROJECTS\4-01126\2-ENGINEERING\2.0 CAD\4-01126-MAINTENANCE.DWG, LAYOUT, 9/18/2019 3:21:05 PM, mppalk



LEGEND

- CRACK SEAL ONLY (TxDOT 712)
- 5" FLEXIBLE PAVEMENT REPAIR ONLY (TxDOT 351)
- 5" FLEXIBLE PAVEMENT REPAIR AND CRACK SEAL (TxDOT 351 & TxDOT 712)

GENERAL NOTES

1. CRACK SEAL WORK WILL BE SUBSEQUENT TO FLEXIBLE PAVEMENT REPAIR WHEN BOTH ACTIVITIES REQUIRED ON SAME STREET.

REV.	DESCRIPTION	DATE



CITY OF BASTROP

2019 MAINTENANCE PROGRAM

STREETS MAINTENANCE OVERVIEW

DATE: 09/12/19
DESIGNED BY: R. ALAN MUNGER, PE



DESIGNED	RAM
DRAFTED	KPD/MPP
CHECKED	RAM
PROJECT NO.	4-01126
DRAWING NO.	A

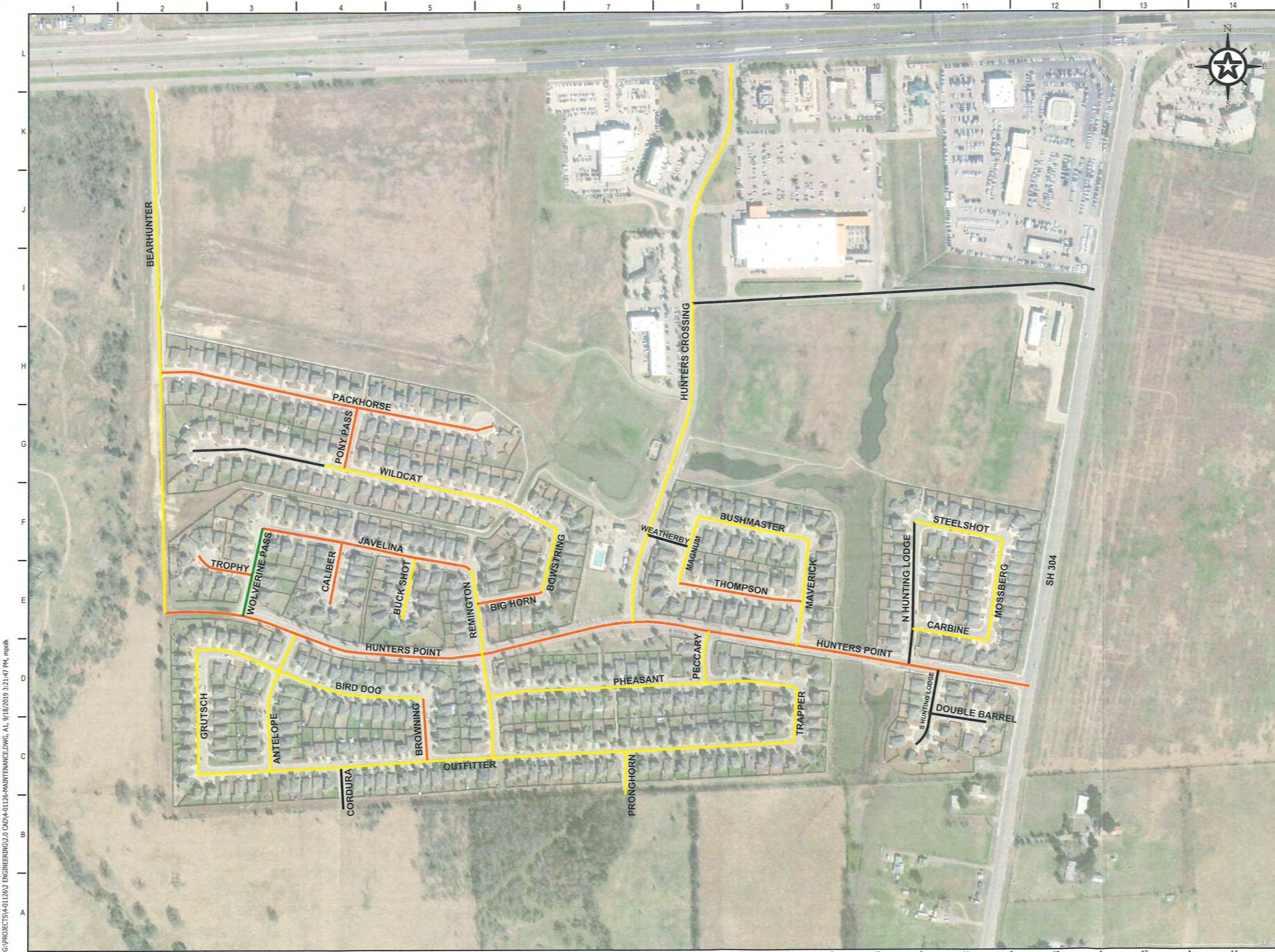

LEGEND

- CRACK SEAL ONLY (TxDOT 712)
- 5" FLEXIBLE PAVEMENT REPAIR ONLY (TxDOT 351)
- 5" FLEXIBLE PAVEMENT REPAIR AND CRACK SEAL (TxDOT 351 & TxDOT 712)

GENERAL NOTES

- CRACK SEAL WORK WILL BE SUBSEQUENT TO FLEXIBLE PAVEMENT REPAIR WHEN BOTH ACTIVITIES REQUIRED ON SAME STREET.

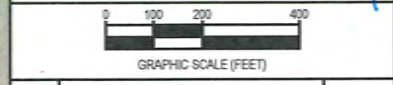

REV.	DESCRIPTION	DATE

Walker Partners
engineers • surveyors
T.S.P.E. Registration No. 800

CITY OF BASTROP
2019 MAINTENANCE PROGRAM
STREETS MAINTENANCE MAP A1

DATE: 09/12/19
 DESIGNED BY: R. Alan Munger, PE
 R. ALAN NUMBER: 85341

DESIGNED	RAM
DRAWN	RAM
CHECKED	KPD/MPP
PROJECT NO.	RAM
	4-01126
DRAWING NO.	A1

G:\PROJECTS\14-01126\ENGINEERING\2.0 CAD\14-01126-MAINTENANCE.DWG, A1, 9/18/2019 3:21:47 PM, rmpolk

G:\PROJECTS\4-01126\2-ENGINEERING\2.0 CAD\4-01126-MAINTENANCE\DWG, A2, 9/18/2019 3:22:11 PM, mppk



LEGEND	
	CRACK SEAL ONLY (TxDOT 712)
	5" FLEXIBLE PAVEMENT REPAIR ONLY (TxDOT 351)
	5" FLEXIBLE PAVEMENT REPAIR AND CRACK SEAL (TxDOT 351 & TxDOT 712)

GENERAL NOTES

1. CRACK SEAL WORK WILL BE SUBSEQUENT TO FLEXIBLE PAVEMENT REPAIR WHEN BOTH ACTIVITIES REQUIRED ON SAME STREET.

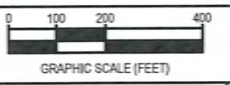

REV.	DESCRIPTION	DATE



CITY OF BASTROP

2019 MAINTENANCE PROGRAM

STREETS MAINTENANCE MAP A2



DATE: 09/12/19
 BY: R. Alan Munger, PE

DESIGNED	RAM
DRAFTED	KPDMPP
CHECKED	RAM
PROJECT NO.	4-01126
DRAWING NO.	A2

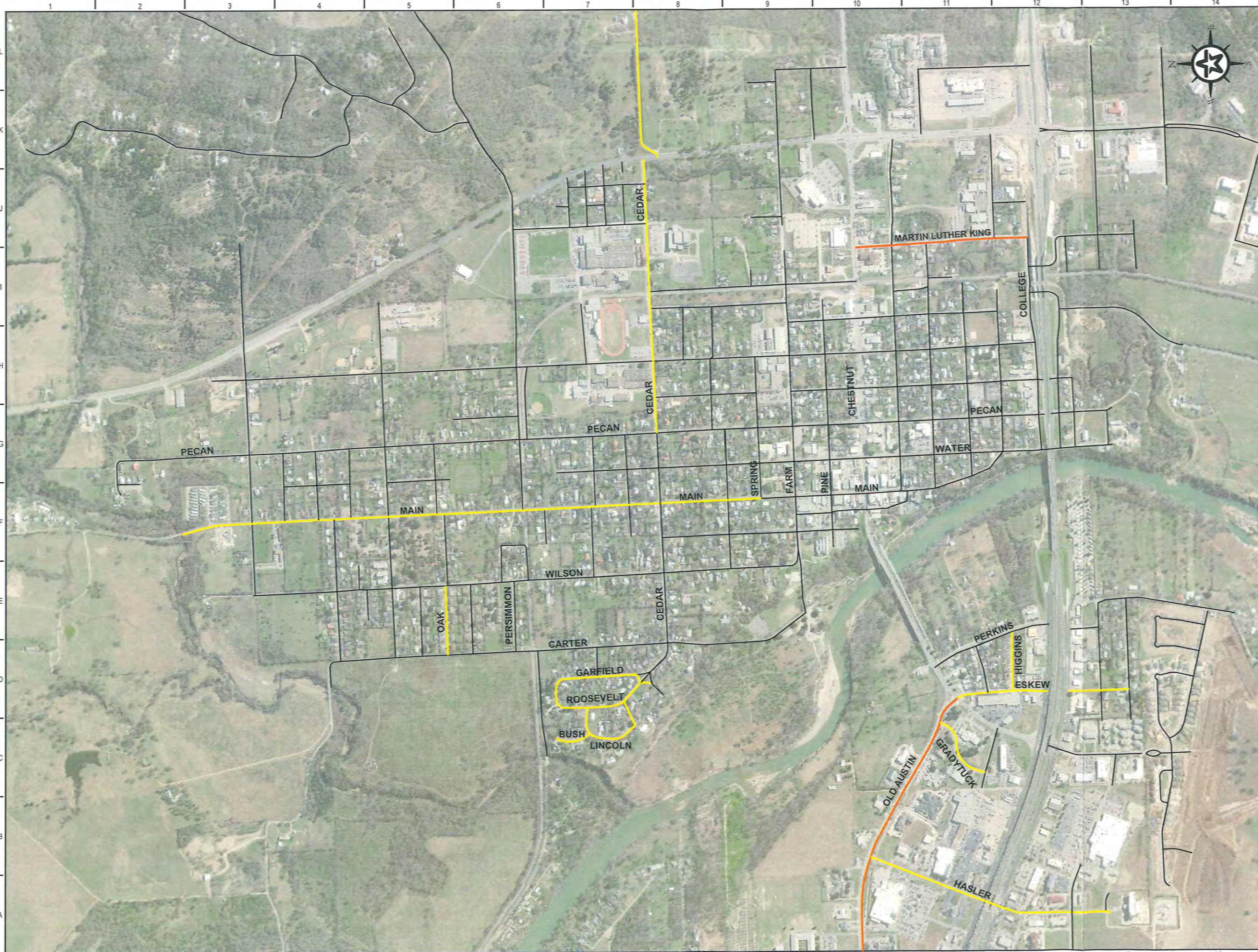

G:\PROJECTS\4-01126\2 ENGINEERING\2.0 CAD\4-01126-MAINTENANCE\DWG_A3_9/18/2019 3:22:31 PM.mpd



LEGEND	
	CRACK SEAL ONLY (TxDOT 712)
	5" FLEXIBLE PAVEMENT REPAIR ONLY (TxDOT 351)
	5" FLEXIBLE PAVEMENT REPAIR AND CRACK SEAL (TxDOT 351 & TxDOT 712)

GENERAL NOTES

- CRACK SEAL WORK WILL BE SUBSEQUENT TO FLEXIBLE PAVEMENT REPAIR WHEN BOTH ACTIVITIES REQUIRED ON SAME STREET.

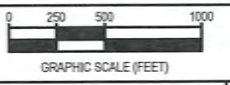

REV.	DESCRIPTION	DATE



CITY OF BASTROP
2019 MAINTENANCE PROGRAM
STREETS MAINTENANCE MAP A3

DATE: 09/12/19
 R. ALAN MUNGER, PE

	DESIGNED	RAM
	DRAWN	RAM
	CHECKED	KPD/MPP
	PROJECT NO.	4-01126
	DRAWING NO.	A3

STREETS MAINTENANCE - CRACK SEAL AND FLEXIBLE PAVEMENT REPAIR

ROAD NAME	FROM	TO	LENGTH OF PAY - CRACK SEAL (L-MI)	FLEXIBLE PAVEMENT REPAIR (5 INCH DEPTH) (SY)
Map A1				
ANTELOPE	HUNTERS POINT	OUTFITTER	0.22	None
BEARHUNTER	SH 71	END	1.06	None
BIG HORN	BOWSTRING	REMINGTON	0.19	13
BIRD DOG	GRUTSCH	BROWNING	0.18	None
BOWSTRING	WILDCAT	REMINGTON	0.18	None
BROWNING	BIRD DOG	OUTFITTER	0.10	57
BUCK SHOT	END	JAVELINA	1.12	None
BUSHMASTER	MAGNUM	MAVERICK	0.20	None
CALIBER	END	JAVELINA	0.13	453
CARBINE	N HUNTING LODGE	MOSSBERG	0.13	None
CORDURA	END	OUTFITTER	None	None
DOUBLEBARREL	END	S HUNTING LODGE	None	None
GRUTSCH	BIRD DOG	OUTFITTER	0.13	None
HUNTERS CROSSING	SH 71	HUNTERS POINT	2.09	None
HUNTERS POINT	BEARHUNTER	SH 304	1.26	810
JAVELINA	WOLVERINE	REMINGTON	0.16	974
MAGNUM	BUSHMASTER	THOMPSON	0.19	None
MAVERICK	BUSHMASTER	HUNTERS POINT	0.50	None
MOSSBERG	STEELSHOT	CARBINE	0.13	None
N HUNTING LODGE	STEELSHOT	HUNTERS POINT	None	None
OUTFITTER	GRUTSCH	TRAPPER	0.83	None
PACKHORSE	BEARHUNTER	END	0.13	40
PECCARY	HUNTERS POINT	PHEASANT	0.11	None
PHEASANT	REMINGTON	TRAPPER	0.79	None
PONY PASS	PACKHORSE	WILDCAT	0.10	10
PRONGHORN	END	OUTFITTER	0.08	None
REMINGTON	JAVELINA	OUTFITTER	0.30	None
S HUNTING LODGE	HUNTERS POINT	END	None	None
STEELSHOT	N HUNTING LODGE	MOSSBERG	0.13	None
THOMPSON	MAGNUM	MAVERICK	0.31	27
TRAPPER	PHEASANT	OUTFITTER	0.19	None
TROPHY	END	WOLVERINE	0.30	353
WEATHERBY	HUNTERS CROSSING	MAGNUM	None	None
WILDCAT	END	BOWSTRING	0.40	None
WOLVERINE PASS	JAVELINA	HUNTERS POINT	None	1654
Sub Total Sheet A1			11.64	4391

STREETS MAINTENANCE - CRACK SEAL AND FLEXIBLE PAVEMENT REPAIR

ROAD NAME	FROM	TO	LENGTH OF PAY - CRACK SEAL (L-MI)	FLEXIBLE PAVEMENT REPAIR (5 INCH DEPTH) (SY)
Map A2				
ANNIKA	PATTON	NICOLE	0.59	8
BARBARA	SCHAEFFER	HASLER SHORES	0.36	NONE
BELINDA	END	END	0.07	NONE
BILLS	END	KATY B	0.02	NONE
BLAIR	END	HASLER SHORES	1.20	32
BOB BRYANT PARK	END	CHARLES	0.21	NONE
BRYANT	BLAIR	JESSICA	0.46	150
CAROLE	SCHAEFFER	END	0.15	NONE
CAYLOR	END	KATY B	0.13	NONE
CHARLES	END	HASLER SHORES	1.94	641
ELIZABETH	SCHAEFFER	HASLER SHORES	0.37	NONE
HASLER SHORES	END	OLD AUSTIN	NONE	364
JENNIFER	BLAIR	JESSICA	0.52	NONE
JESSICA	END	HASLER SHORES	1.49	224
JORDAN	END	END	0.20	NONE
KATY B	BLAIR	JESSICA	0.23	4
KELLY	SCHAEFFER	END	0.18	8
LORI	END	END	0.08	NONE
MARINO	END	KATY B	0.14	NONE
NICOLE	CHARLES	JESSICA	0.89	703
OLD AUSTIN HIGHWAY	SH 71	LP 150	4.24	648
PATTON	END	BLAIR	0.08	46
REBECCA	SCHAEFFER	HASLER SHORES	0.37	NONE
SCHAEFFER	CHARLES	OLD AUSTIN	NONE	245
Sub Total Sheet A2			13.92	3073

STREETS MAINTENANCE - CRACK SEAL AND FLEXIBLE PAVEMENT REPAIR

ROAD NAME	FROM	TO	LENGTH OF PAY - CRACK SEAL (L-MI)	FLEXIBLE PAVEMENT REPAIR (5 INCH DEPTH) (SY)
Map A3				
BUSH	END	LINCOLN	0.20	NONE
CEDAR	PECAN	RR	0.58	NONE
CEDAR	RR	SH 95	0.60	NONE
CEDAR	SH 95	HOUSTON	0.49	NONE
ESKEW	LP 150	SH 71	0.43	NONE
ESKEW	SH 71	MAYNARD	0.25	NONE
GRADYTUCK	OLD AUSTIN	HOSPITAL	0.52	NONE
HASLER	OLD AUSTIN	SH 71	1.00	NONE
HASLER	SH 71	END	0.97	NONE
HIGGINS	ESKEW	PERKINS	0.21	NONE
LINCOLN	ROOSEVELT	ROOSEVELT	0.53	NONE
MAIN	BRIDGE	RR	1.38	NONE
MAIN	RR	SPRING	1.28	NONE
MARTIN LUTHER KING	CHESTNUT	COLLEGE	0.70	444
OAK	CARTER	WILSON	0.36	NONE
ROOSEVELT - GARFIELD	CEDAR	CEDAR	0.94	NONE
Sub Total Sheet A3			10.44	444
TOTAL			36.00	7908.00



G:\PROJECTS\4-01126\2. ENGINEERING\2.0 CAD\4-01126-PREVENTATIVE MAINTENANCE.DWG, LAYOUT1, 9/12/2019 8:39:43 AM, mpolk

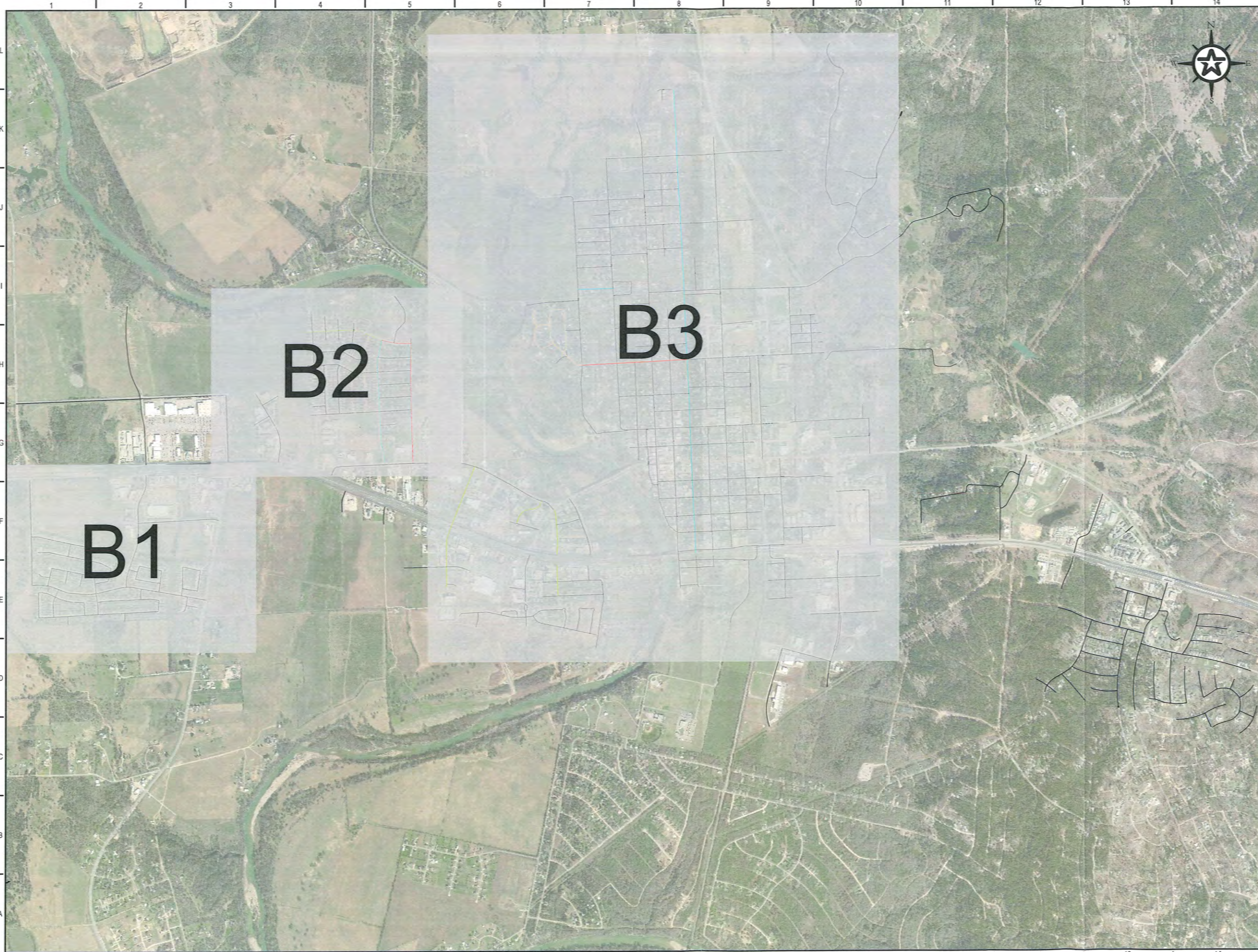

LEGEND

- SEAL COAT (TxDOT 316)
- SCRUB SEAL (TxDOT 3005)
- FOG SEAL (TxDOT 315)
- FRICTIONAL ASPHALTIC SURFACE PRESERVATION TREATMENT (TxDOT 3028)

REV.	DESCRIPTION	DATE



CITY OF BASTROP
2019 MAINTENANCE PROGRAM
PREVENTATIVE MAINTENANCE OVERVIEW

09/12/19
 DATE *R. Alan Munger, PE*
 R. ALAN MUNGER



DESIGNED	RAM
DRAWN	KPD/MPP
CHECKED	RAM
PROJECT NO.	4-01126
DRAWING NO.	B

G:\PROJECTS\4-01126\2 ENGINEERING\2.0 CAD\4-01126-PREVENTATIVE MAINTENANCE.DWG, B1, 9/12/2019 8:41:09 AM, mmpk



LEGEND

- SEAL COAT (TxDOT 316)
- SCRUB SEAL (TxDOT 3005)
- FOG SEAL (TxDOT 315)
- FRICTIONAL ASPHALTIC SURFACE PRESERVATION TREATMENT (TxDOT 3028)

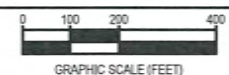

REV.	DESCRIPTION	DATE



CITY OF BASTROP
2019 MAINTENANCE PROGRAM
PREVENTATIVE MAINTENANCE MAP B1

09/12/19 DATE *R. Alan Munger, PE* R. ALAN MUNGER

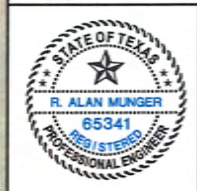

DESIGNED	RAM
DRAWN	RAM
CHECKED	KPD/MPP
PROJECT NO.	4-01126
DRAWING NO.	B1

G:\PROJECTS\4-01126\2 ENGINEERING\2.0 CAD\4-01126-PREVENTATIVE MAINTENANCE.DWG, B3, 9/12/2019 8:42:09 AM, mpolk

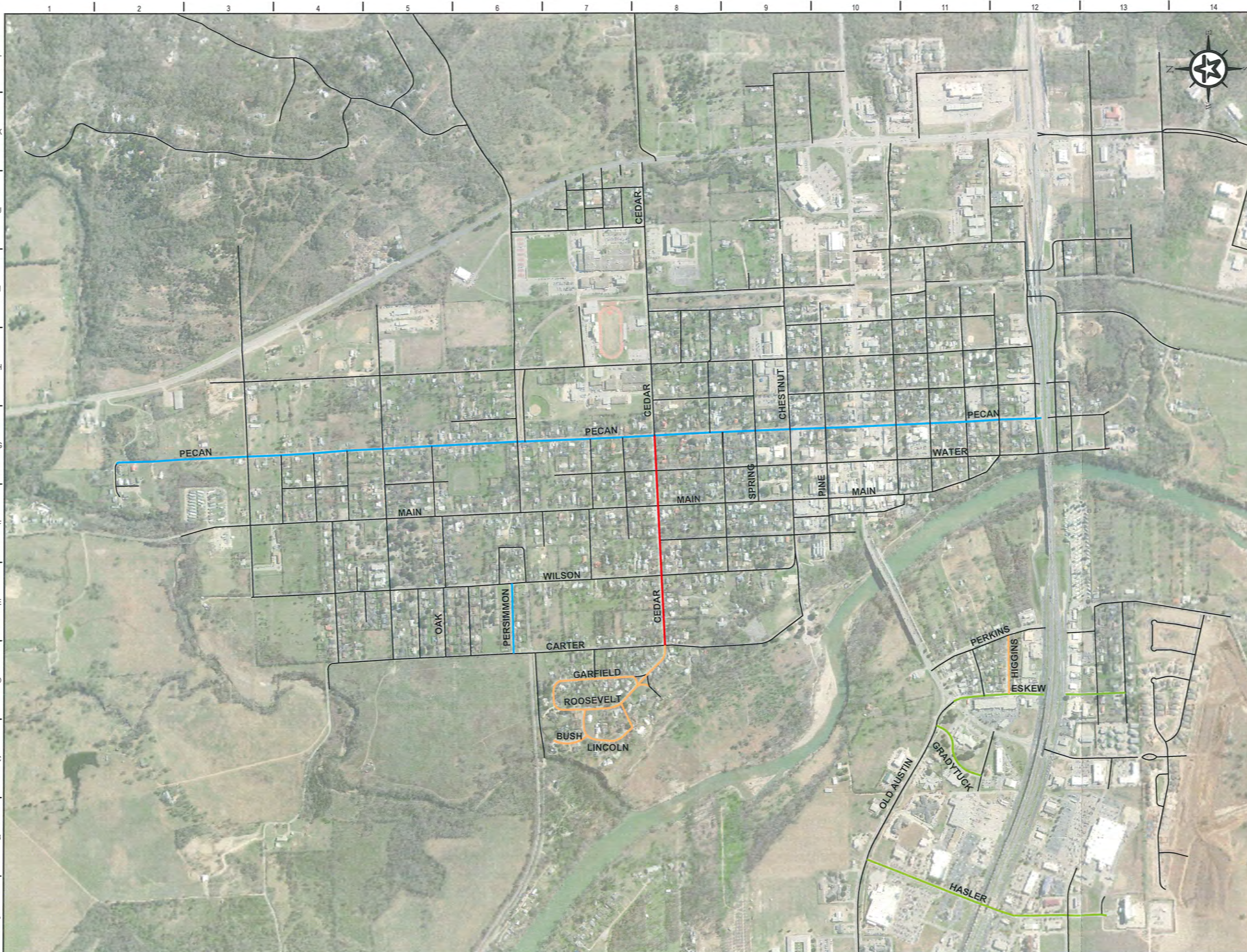

LEGEND

- SEAL COAT (TxDOT 316)
- SCRUB SEAL (TxDOT 3005)
- FOG SEAL (TxDOT 315)
- FRICTIONAL ASPHALTIC SURFACE PRESERVATION TREATMENT (TxDOT 3028)

GENERAL NOTES

1. FOG SEAL (CSS-1) SHALL BE PLACED AT ALL FLEXIBLE PAVEMENT REPAIRS PRIOR TO PLACEMENT OF SCRUB SEAL.

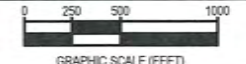

REV.	DESCRIPTION	DATE



CITY OF BASTROP

2019 MAINTENANCE PROGRAM

PREVENTATIVE MAINTENANCE MAP B3

DATE: 09/12/19 *R. Alan Munger, PE*
R. ALAN MUNGER



DESIGNED	RAM
DRAFTED	KPD/MPP
CHECKED	RAM
PROJECT NO.	4-01126
DRAWING NO.	B3

PREVENTATIVE MAINTENANCE - SEAL COAT TREATMENT (AC-20 TR with TY PB GRADE 4 TRAP ROCK)

ROAD NAME	FROM	TO	LENGTH (FT)	WIDTH (FT)	AREA (SY)
Map B1					
NONE	NONE	NONE			0
Map B2					
SCHAEFFER	CHARLES	OLD AUSTIN	2731	41.5	12592.94
Map B3					
PECAN	MESQUITE	RR	3009	24	8024
PECAN	RR	CHESTNUT	3770	27	11310
PECAN	CHESTNUT	SH 71 WBFR	1925	35	7486.111
PERSIMMON	WILSON	CARTER	744	28	2314.667
Sub Total SEAL COAT					41727.72

PREVENTATIVE MAINTENANCE - SCRUB SEAL TREATMENT (CMS-2P with TY B GR 4 TRAP ROCK AGGR)

ROAD NAME	FROM	TO	LENGTH (FT)	WIDTH (FT)	AREA (SY)
Map B1					
NONE	NONE	NONE	0	0	0
Map B2					
CHARLES	SCHAEFFER	HASLER SHORES	670	47	3498.889
HASLER SHORES	CHARLES	OLD AUSTIN	2656	23	6787.556
Map B3					
CEDAR	CARTER	PECAN	2347	28	7301.778
Sub Total SCRUB SEAL					17588.22

PREVENTATIVE MAINTENANCE - FRICTIONAL ASPHALTIC SURFACE PRESERVATION TREATMENT

ROAD NAME	FROM	TO	LENGTH (FT)	WIDTH (FT)	AREA (SY)
Map B1					
NONE	NONE	NONE	0	0	0
Map B2					
BRYANT	BLAIR	JESSICA	868	28	2700.444
KELLY	SCHAEFFER	END	220	27	1185
NICOLE	CHARLES	JESSICA	1695	28	5273.333
Map B3					
BUSH	END	LINCOLN	317	28	1264.222
CEDAR	GARFIELD	CARTER	371	28	1154.222
HIGGINS	ESKEW	PERKINS	631	28	1963.111
LINCOLN	ROOSEVELT	ROOSEVELT	1158	28	3602.667
ROOSEVELT - GARFIELD	CEDAR	CEDAR	2480	28	7715.556
Sub Total (FASPT)					24858.56

PREVENTATIVE MAINTENANCE - FOG SEAL (CMS-1PF)

ROAD NAME	FROM	TO	LENGTH (FT)	WIDTH (FT)	AREA (SY)
Map B1					
NONE	NONE	NONE	0	0	0
Map B2					
CHARLES	END	SCHAEFFER	1714	47	8950.889
Map B3					
ESKEW	LP 150	SH 71	925	28	2877.778
ESKEW	SH 71	MAYNARD	664	19	1401.778
GRADYTUCK	OLD AUSTIN	HOSPITAL	794	34	2999.556
HASLER	OLD AUSTIN	SH 71	1112	36	5482
HASLER	SH 71	END	1223	36	4892
Sub Total (FOG SEAL CMS-1PF)					26604

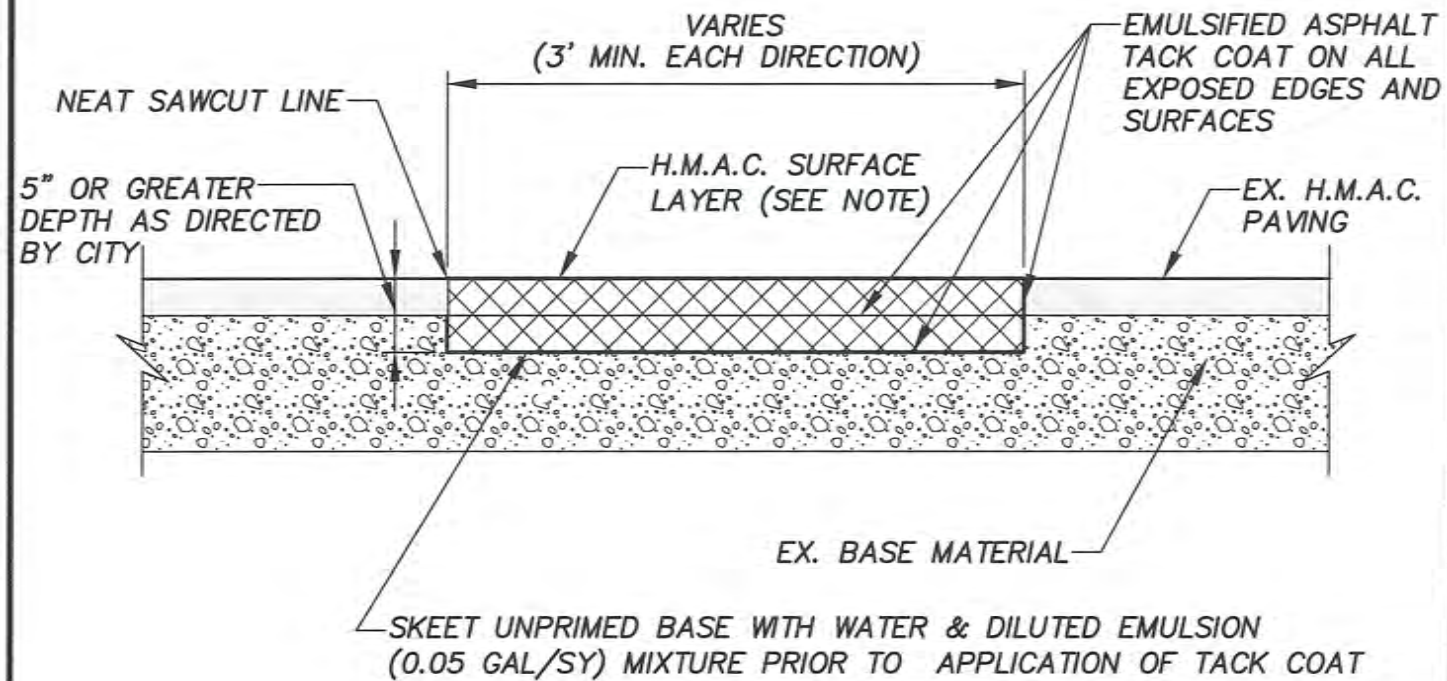

NOTE

1. REPLACEMENT H.M.A.C. SURFACE LAYER SHALL BE OF TYPE AND THICKNESS BASED ON DEPTH OF REPAIR.

-REPAIRS OF 5" DEPTH OR LESS MAY CONSIST OF A SINGLE COMPACTED LIFT OF TYPE B ASPHALT (TxDOT ITEM 340).

-REPAIRS OF GREATER THAN 5" DEPTH SHALL CONSIST OF TWO COMPACTED LIFTS. SURFACE COURSE MAY CONSIST OF 2" MIN. DEPTH OF TYPE D OR TYPE C ASPHALT (TxDOT ITEM 340).



R. Alan Munger, PE

FLEXIBLE PAVEMENT REPAIR DETAIL

SCALE: N.T.S.	CLIENT NAME: CITY OF BASTROP	C001
 <p>T.B.P.E. Registration No. 8053</p>	PROJECT NAME: STREETS MAINTENANCE	
	PROJECT NUMBER: 4-01126	
	DATE: 09/12/19	
	REVISION: NA	

AL

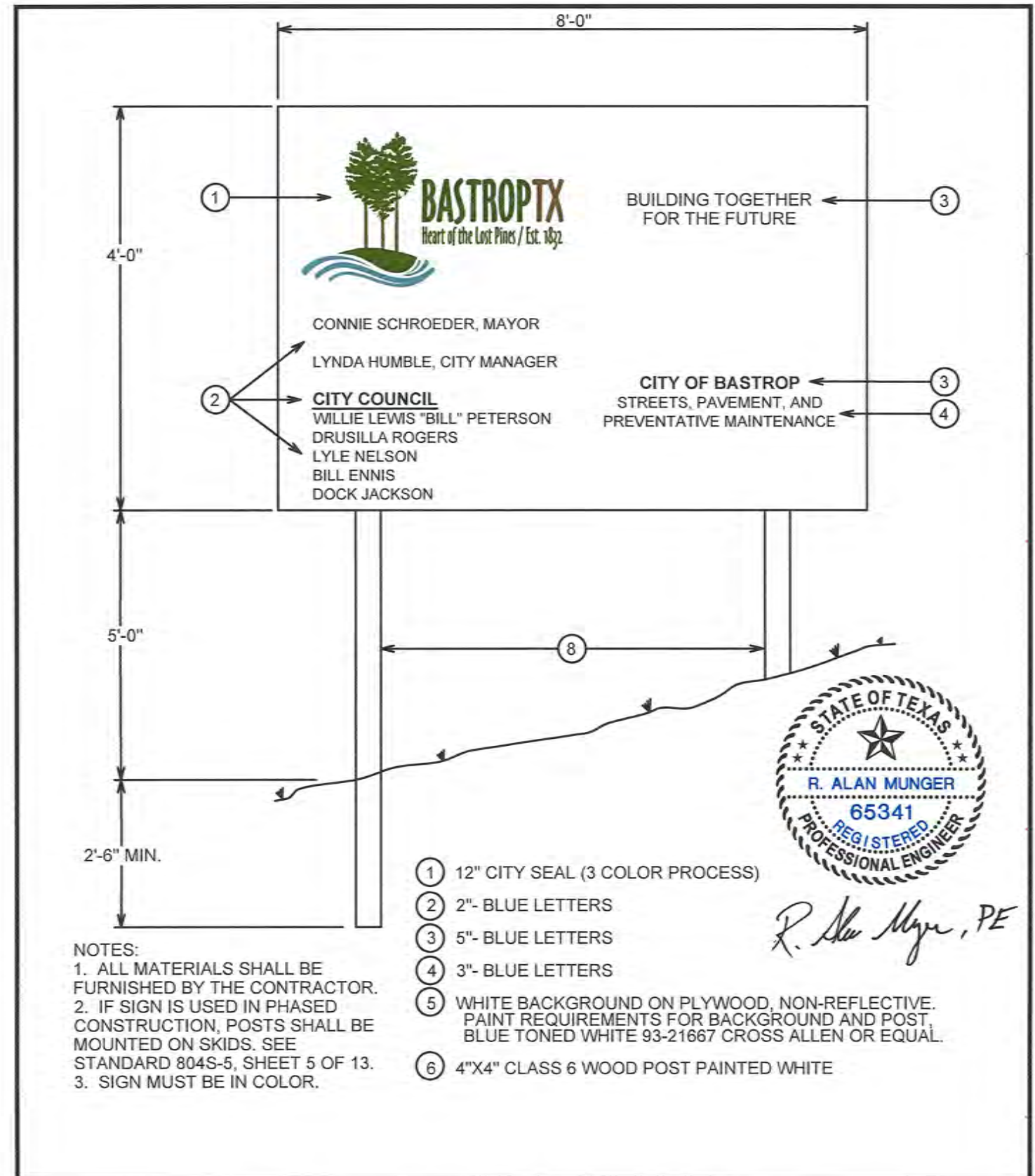

NOTES:
 1. ALL MATERIALS SHALL BE FURNISHED BY THE CONTRACTOR.
 2. IF SIGN IS USED IN PHASED CONSTRUCTION, POSTS SHALL BE MOUNTED ON SKIDS. SEE STANDARD 804S-5, SHEET 5 OF 13.
 3. SIGN MUST BE IN COLOR.

- ① 12" CITY SEAL (3 COLOR PROCESS)
- ② 2"- BLUE LETTERS
- ③ 5"- BLUE LETTERS
- ④ 3"- BLUE LETTERS
- ⑤ WHITE BACKGROUND ON PLYWOOD, NON-REFLECTIVE. PAINT REQUIREMENTS FOR BACKGROUND AND POST, BLUE TONED WHITE 93-21667 CROSS ALLEN OR EQUAL.
- ⑥ 4"X4" CLASS 6 WOOD POST PAINTED WHITE



R. Alan Munger, PE

8'X4' C.I.P. BUILDING PROJECT SIGN

SCALE: N.T.S.



T.B.P.E. Registration No. 8053

CLIENT NAME: CITY OF BASTROP
 PROJECT NAME: STREETS MAINTENANCE
 PROJECT NUMBER: 4-01126
 DATE: 09/12/19
 REVISION: NA

C002

PHASES/TASKS	December	January	February	March	April	May	June	July
Flexible Pavement Repair	[Yellow bar]							
Manhole Grade Adjustment	[Red bar]							
NT/Crack Seal	[Green bar]							
Fog Seal					[Orange bar]			
Fractional Asphaltic Surface Preservation Treatment					[Blue bar]			
Scrub Seal					[Yellow bar]			
Seal Coat or TOM						[Green bar]		
		Bastrop ISD Holiday						

SEQUENCE OF CONSTRUCTION

1. CONSTRUCTION OF TASKS MAY BE CONCURRENT.
2. WORK THAT IS COMMENCED ON AN INDIVIDUAL STREET SHALL BE COMPLETED WITHIN 5 DAYS.
3. AT LEAST ONE LANE SHALL REMAIN OPEN ON A STREET (WITH FLAGGER CONTROL) DURING WORK ACTIVITIES.
4. DURING WORK ACTIVITIES ON OLD AUSTIN HIGHWAY, TRAFFIC SHALL REMAIN OPEN IN EACH DIRECTION.
5. NO DROP OFFS SHALL REMAIN OVERNIGHT. USE OF STEEL PLATES IS PERMISSIBLE IN ACCORDANCE WITH DETAILS C004-C006. PAYMENT FOR PLATES IS INCIDENTAL TO THE OTHER BID ITEMS AND THERE WILL BE NO INDIVIDUAL PAY FOR THEIR USE.

SEQUENCE OF CONSTRUCTION

SCALE: N.T.S.

CLIENT NAME: CITY OF BASTROP
 PROJECT NAME: STREETS MAINTENANCE
 PROJECT NUMBER: 4-01126
 DATE: 09/23/19
 REVISION: NA

C003



ak

PLATES MAY EXTEND COMPLETELY ACROSS ROADWAY

TEMPORARY BACKFILL

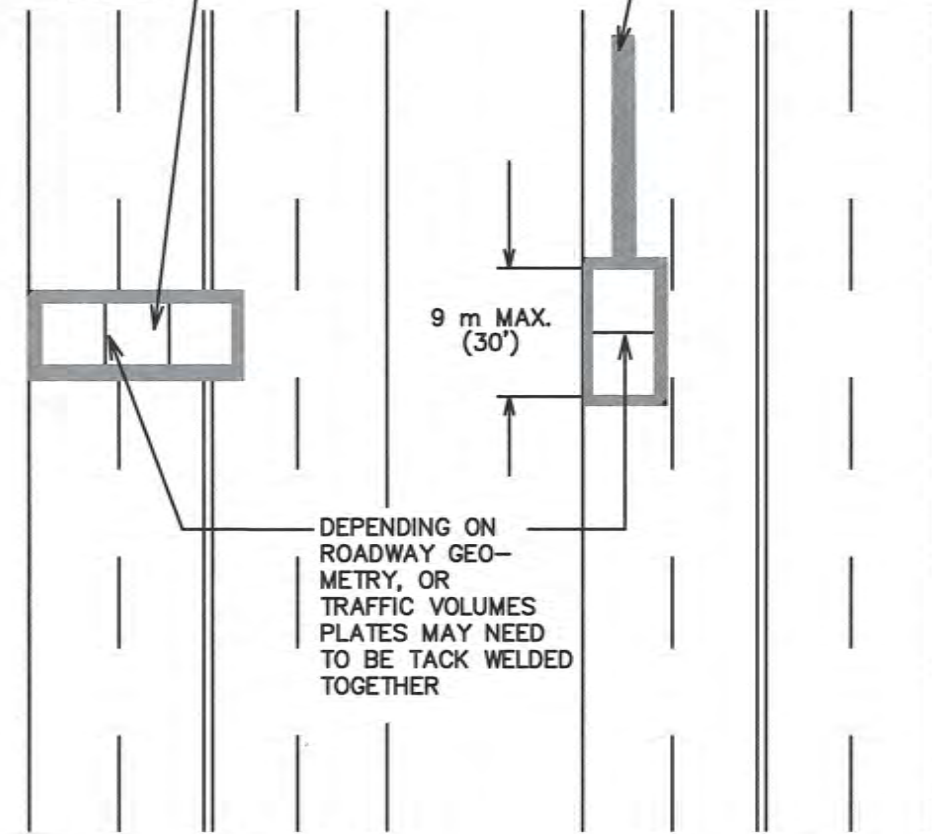

DEPENDING ON ROADWAY GEO-METRY, OR TRAFFIC VOLUMES PLATES MAY NEED TO BE TACK WELDED TOGETHER

LATERAL PLATING

LONGITUDINAL PLATING

STEEL PLATING

SCALE: N.T.S.

CLIENT NAME: CITY OF BASTROP

PROJECT NAME: STREETS MAINTENANCE

PROJECT NUMBER: 4-01126

DATE: 09/23/19

REVISION: NA

 **Walker Partners**
engineers ★ surveyors

T.B.P.E. Registration No. 8053

C004

SPK

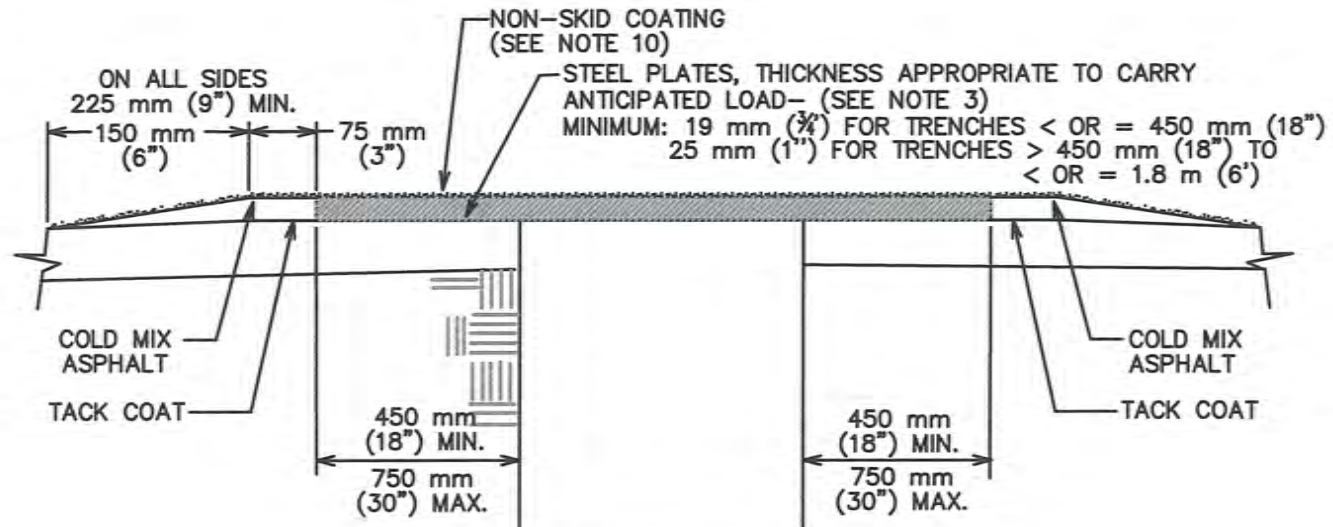

TYPICAL CROSS SECTION

CASE I- LOW TRAFFIC VOLUME/LIMITED IN-SERVICE TIME

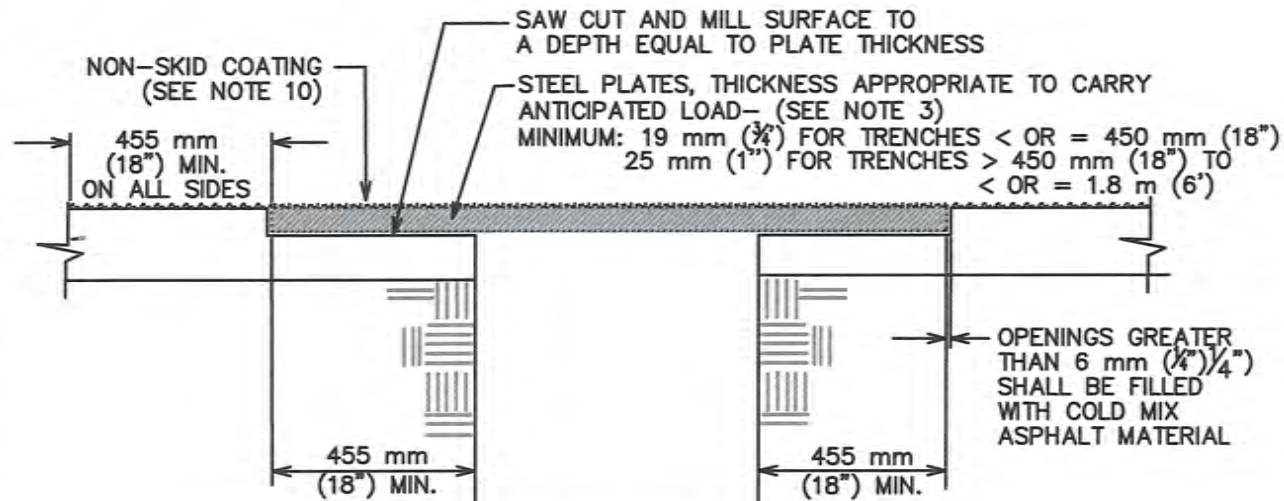

TYPICAL CROSS SECTION

CASE II- EXTENDED IN-SERVICE PLATING AND/OR
HEAVILY-TRAFFICKED ROADS/STREETS
(HMAC PAVEMENTS ONLY)

STEEL PLATING

SCALE: N.T.S.

CLIENT NAME: CITY OF BASTROP

PROJECT NAME: STREETS MAINTENANCE

PROJECT NUMBER: 4-01126

DATE: 09/23/19

REVISION: NA

 **Walker Partners**
engineers ★ surveyors

T.B.P.E. Registration No. 8053

C005

ad

NOTES:

1. WHERE TRAFFIC MUST CROSS TRENCHES, THE CONTRACTOR SHALL PROVIDE SUITABLE BRIDGES.
2. THE USE OF STEEL PLATES SHALL BE APPROVED BY THE RIGHT OF WAY MANAGEMENT DIVISION OF WATERSHED PROTECTION AND DEVELOPMENT DEPARTMENT PRIOR TO INITIATION OF CONSTRUCTION.
3. THE THICKNESS OF PLATES FOR TRENCH WIDTHS EXCEEDING 1.8 m (6') SHALL BE ESTABLISHED IN AN ANALYSIS COMPLETED BY A LICENSED PROFESSIONAL ENGINEER, REGISTERED IN THE STATE OF TEXAS. THE ANALYSIS SHALL BE BASED ON HS-20 TRAFFIC LOADING WITH A MAXIMUM PLATE DEFLECTION OF 50 mm (2") WHEN EXPERIENCING SAID LOADING. FOR SITUATIONS WHERE MULTIPLE LAYERS OF PLATES (OR STACKED PLATES) ARE TO BE EMPLOYED, THE SEAMS (IE. THE INTER-FACE BETWEEN PLACED SIDE-BY-SIDE) OF THE UPPER LAYER SHALL BE PLACED PERPENDICULAR TO THE SEAMS OF THE UNDERLYING PLATES.
4. WHEN APPROVED, THE TYPE OF PLATE INSTALLATION SHALL BE BASED ON THE ANTICIPATED LENGTH OF TIME THE PLATE WILL BE IN SERVICE: CASE I: A CASE I INSTALLATION SHALL APPLY FOR NO LONGER THAN A 2 WEEK PERIOD. CASE II: A CASE II INSTALLATION SHALL APPLY FOR NO LONGER THAN 2 WEEK PERIOD.
5. THE TOPSIDE OF THE STEEL PLATE SHALL BE FLAT AND FREE OF ANY CLIPS, CHAINS, ATTACHMENTS, WELDMENTS OR SURFACE IRREGULARITIES.
6. PLATES WITH A PERMANENT DISPLACEMENT (I.E. DISPLACEMENT ANYWHERE ON THE SURFACE OF THE PLATE WITH RESPECT TO A PLANE FORMED BY THE OUTSIDE EDGES) THAT EXCEEDS 12 mm (1/2") SHALL NOT BE USED FOR PLATING PURPOSES. PLATES THAT DEVELOP A PERMANENT DISPLACEMENT EXCEEDING 12 mm (1/2") DURING SERVICE SHALL BE REMOVED AND REPLACED.
7. THE PLATES SHALL BE PROVIDED WITH APPROPRIATE NUMBER OF KEYHOLE SLOTS OR CIRCULAR HOLES FOR HANDLING, LIFTING, INSTALLATION AND REMOVAL PURPOSES.
8. THE CONTRACTOR SHOULD AVOID USING A LONG SERIES OF PLATES THAT RUN PARALLEL TO VEHICULAR TRAFFIC WHEELS PATHS.
9. ADDITIONAL METHODS OF SECURING PLATES MAY BE REQUIRED DEPENDING ON FIELD CONDITIONS.
10. FOR PLATES 1.8 M (6") OR GREATER IN DIRECTION OF TRAFFIC, A NON-SKID COATING SHOULD BE APPLIED TO THE ENTIRE SURFACE AREA OF ALL PLATES, AS WELL AS ADJACENT AREAS. THE NON-SKID COATING SHALL BE TCA (TEXTURED COATING OF AMERICA, INC.) STRATA-GRIP DECK COATING SYSTEM; SLIPFIX, INC. SPS (SLIP PROTECTION SURFACE) OR AN EQUIVALENT PRODUCT APPROVED BY THE ENGINEER OR DESIGNATED REPRESENTATIVE.

STEEL PLATING

SCALE: N.T.S.



CLIENT NAME: CITY OF BASTROP
PROJECT NAME: STREETS MAINTENANCE
PROJECT NUMBER: 4-01126
DATE: 09/23/19
REVISION: NA

C006